

WAGO → I/O → SYSTEM 750

**Fieldbus Independent
I/O Modules**

**2 DO DC 24 V EEx i, High-Side
Switching
750-535**



Manual

Version 1.0.5

Copyright © 2006 by WAGO Kontakttechnik GmbH & Co. KG
All rights reserved.

WAGO Kontakttechnik GmbH & Co. KG

Hansastraße 27
D-32423 Minden

Phone: +49 (0) 571/8 87 – 0

Fax: +49 (0) 571/8 87 – 1 69

E-Mail: info@wago.com

Web: <http://www.wago.com>

Technical Support

Phone: +49 (0) 571/8 87 – 5 55

Fax: +49 (0) 571/8 87 – 85 55

E-Mail: support@wago.com

Every conceivable measure has been taken to ensure the correctness and completeness of this documentation. However, as errors can never be fully excluded, we would appreciate any information or ideas at any time.

E-Mail: documentation@wago.com

We wish to point out that the software and hardware terms as well as the trademarks of companies used and/or mentioned in the present manual are generally trademark or patent protected.

CONTENT

1 Important Comments	4
1.1 Legal Principles	4
1.1.1 Copyright	4
1.1.2 Personnel Qualification	4
1.1.3 Intended Use	4
1.2 Symbols	5
1.3 Number Notation	5
1.4 Safety Notes	6
1.5 Scope	6
2 I/O Modules	7
2.1 Digital Output Modules	7
2.1.1 750-535 [2 DO DC 24 V EEx i, High-Side Switching]	7
2.1.1.1 View	7
2.1.1.2 Description	7
2.1.1.3 Display Elements	9
2.1.1.4 Schematic Diagram	9
2.1.1.5 Technical Data	10
2.1.1.6 Process Image	11
3 Use in Hazardous Environments	12
3.1 Foreword	12
3.2 Protective measures	12
3.3 Classification meeting CENELEC and IEC	12
3.3.1 Divisions	12
3.3.2 Explosion protection group	13
3.3.3 Unit categories	14
3.3.4 Temperature classes	14
3.3.5 Types of ignition protection	15
3.4 Classifications meeting the NEC 500	16
3.4.1 Divisions	16
3.4.2 Explosion protection groups	16
3.4.3 Temperature classes	17
3.5 Identification	18
3.5.1 For Europe	18
3.5.2 For America	19
3.6 Installation regulations	20

1 Important Comments

To ensure fast installation and start-up of the units described in this manual, we strongly recommend that the following information and explanations are carefully read and abided by.

1.1 Legal Principles

1.1.1 Copyright

This manual is copyrighted, together with all figures and illustrations contained therein. Any use of this manual which infringes the copyright provisions stipulated herein, is not permitted. Reproduction, translation and electronic and photo-technical archiving and amendments require the written consent of WAGO Kontakttechnik GmbH & Co. KG. Non-observance will entail the right of claims for damages.

WAGO Kontakttechnik GmbH & Co. KG reserves the right to perform modifications allowed by technical progress. In case of grant of a patent or legal protection of utility patents all rights are reserved by WAGO Kontakttechnik GmbH & Co. KG. Products of other manufacturers are always named without referring to patent rights. The existence of such rights can therefore not be ruled out.

1.1.2 Personnel Qualification

The use of the product detailed in this manual is exclusively geared to specialists having qualifications in PLC programming, electrical specialists or persons instructed by electrical specialists who are also familiar with the valid standards. WAGO Kontakttechnik GmbH & Co. KG declines all liability resulting from improper action and damage to WAGO products and third party products due to non-observance of the information contained in this manual.

1.1.3 Intended Use

For each individual application, the components supplied are to work with a dedicated hardware and software configuration. Modifications are only permitted within the framework of the possibilities documented in the manuals. All other changes to the hardware and/or software and the non-conforming use of the components entail the exclusion of liability on part of WAGO Kontakttechnik GmbH & Co. KG.

Please direct any requirements pertaining to a modified and/or new hardware or software configuration directly to WAGO Kontakttechnik GmbH & Co. KG.

1.2 Symbols



Danger

Always abide by this information to protect persons from injury.



Warning

Always abide by this information to prevent damage to the device.



Attention

Marginal conditions must always be observed to ensure smooth operation.



ESD (Electrostatic Discharge)

Warning of damage to the components by electrostatic discharge. Observe the precautionary measure for handling components at risk.



Note

Routines or advice for efficient use of the device and software optimization.



More information

References on additional literature, manuals, data sheets and INTERNET pages

1.3 Number Notation

Number Code	Example	Note
Decimal	100	normal notation
Hexadecimal	0x64	C notation
Binary	'100' '0110.0100'	Within ', Nibble separated with dots

1.4 Safety Notes



Warning

Switch off the system prior to working on bus modules!

In the event of deformed contacts, the module in question is to be replaced, as its functionality can no longer be ensured on a long-term basis.

The components are not resistant against materials having seeping and insulating properties. Belonging to this group of materials is: e.g. aerosols, silicones, triglycerides (found in some hand creams).

If it cannot be ruled out that these materials appear in the component environment, then additional measures are to be taken:

- installation of the components into an appropriate enclosure
 - handling of the components only with clean tools and materials.
-



Attention

Cleaning of soiled contacts may only be done with ethyl alcohol and leather cloths. Thereby, the ESD information is to be regarded.

Do not use any contact spray. The spray may impair the functioning of the contact area.

The WAGO-I/O-SYSTEM 750 and its components are an open system. It must only be assembled in housings, cabinets or in electrical operation rooms. Access must only be given via a key or tool to authorized qualified personnel.

The relevant valid and applicable standards and guidelines concerning the installation of switch boxes are to be observed.



ESD (Electrostatic Discharge)

The modules are equipped with electronic components that may be destroyed by electrostatic discharge. When handling the modules, ensure that the environment (persons, workplace and packing) is well grounded. Avoid touching conductive components, e.g. gold contacts.

1.5 Scope

This manual describes the Digital Output Module 750-535
2 DO DC 24 V EEx i, High-Side Switching of the modular
WAGO-I/O-SYSTEM 750.

Handling, assembly and start-up are described in the manual of the Fieldbus Coupler. Therefore this documentation is valid only in the connection with the appropriate manual.

2 I/O Modules

2.1 Digital Output Modules

2.1.1 750-535 [2 DO DC 24 V EEx i, High-Side Switching]

2-Channel Digital Output Module DC 24 V
short-circuit-protected, high-side switching, EEx i

2.1.1.1 View

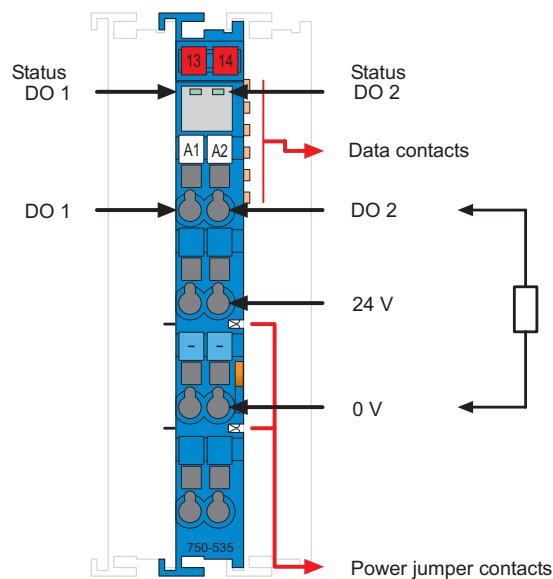

Fig. 2.1.1-1: 2-Channel Digital Output Module 750-535

g053500e

2.1.1.2 Description

The connected load is switched via the digital output from the control system operating in hazardous environments of zone 0+1.

The installation of the WAGO-I/O-SYSTEM 750 is to be done in zone 2 or in non-hazardous environments.

The module has two output channels. Two actuators may be directly connected to the module, for example EEx i magnetic valves. Two actuators may be directly connected to signal output DO1 and 0 V, or to signal output DO 2 and 0 V.

The output channels are electrically short-circuit-protected.



Note

For the connection of inductive loads a protected circuit, e. g. a recovery diode, has to be switched parallel to this load.

The output channels are high-side switching. Which means that the status of the output channels is "high" if the output channels switch to the 24 V supply voltage for the field side.

The supply voltage for the field side is derived from an adjacent supply module by means of power jumper contacts.



Attention

An additional supply module 750-625, DC 24 V EEx i must be added for the approved intrinsically safe field side supply voltage of 24 V.

Supply principle:

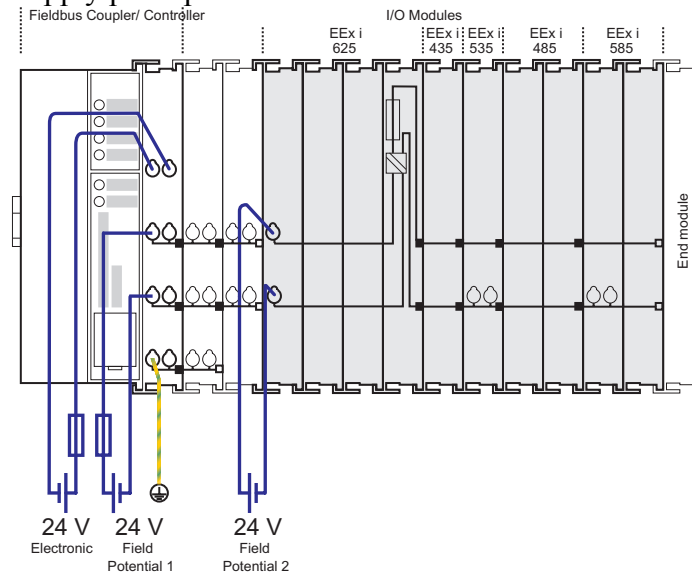

The supply voltage for the field side is made automatically through the individual I/O modules by means of power jumper contacts.

The status of the two output channels is indicated via green status LEDs.

An optocoupler is used for electrical isolation between the bus and the field side.

Any configuration of the input modules is possible within an intrinsically safe segment when designing the fieldbus node. Grouping of module types is not necessary.

**Warning**

The maximum current of the internal power jumper contacts is 10 A. When configuring the system it is important not to exceed the maximum/sum current. However, if such a case should occur, another supply module must be added.

**Note**

If the employment of further DC 24 V EEx i Supply modules is necessary for reasons of extent of utilization, four Separation modules (750-616) must guarantee the distance between the intrinsically safe segments.

**Further Information**

General information to the explosion prevention is in the manual chapter „Use in Hazardous Environments“ described!

The output module 750-535 can be used with all couplers/controllers of the WAGO-I/O-SYSTEM 750.

2.1.1.3 Display Elements

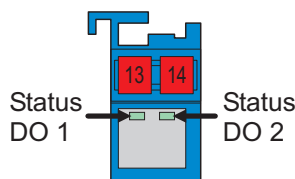

Fig. 2.1.1-2: Display Elements g053502x

LED	Channel	Designation	State	Function
green	1	Status DO 1	off	Output DO 1: not activated
			on	Output DO 1: activated
green	2	Status DO 2	off	Output DO 2: not activated
			on	Output DO 2: activated

2.1.1.4 Schematic Diagram

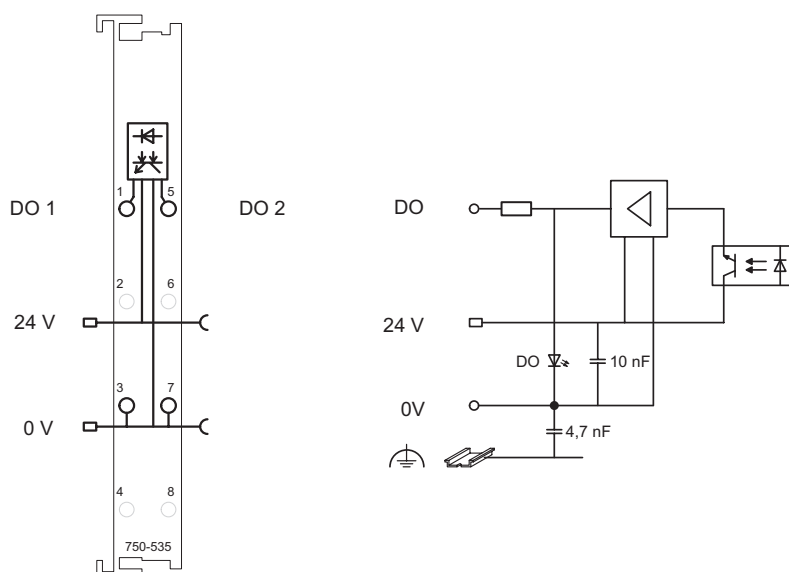







Fig. 2.1.1-3: 2-Channel Digital Output Module 750-535

g053501e

2.1.1.5 Technical Data

Module Specific Data		
Number of outputs	2	
Current consumption(internal)	7 mA	
Voltage via power jumper contacts	DC 24.7 V Supply via 750-625 Supply Module EEx i	
Type of load	resistive, inductive, lamps	
Switching rate _{max.}	1 kHz	
Output data	DC 24 V, Ri: 285 Ω	
Power Consumption P _{max.}	2.1 W (at an output current of 40 mA each)	
Power loss P _V	1.1 W (at an output current of 40 mA each)	
Isolation	375 V (System/Field)	
Input current _{typ.} (Field)	8.5 mA module + load	
Internal bit width	2 Bit out	
Dimensions (mm) W x H x L	12 x 64* x 100 * from upper edge of 35 DIN rail	
Weight	ca. 55 g	
Standards and Regulations (cf. Chapter 2.2 of the Coupler/Controller Manual)		
EMC-Immunity to interference (CE)	acc. to EN 61000-6-2 (1999)	
EMC-Emission of interference (CE)	acc. to EN 61000-6-4 (2002)	
EC EMC directive	89/336/EEC	
EC low voltage directive	73/23/EEC	
Approvals (cf. Chapter 2.2 of the Coupler/Controller Manual)		
 cUL _{US}	cUL _{US} (UL508)	
	ABS (American Bureau of Shipping)	
	BV (Bureau Veritas) (applied for)	
	GL (Germanischer Lloyd)	Cat. A, B, C, D
	KR (Korean Register of Shipping)	
	LR (Lloyd's Register) (applied for)	Env. 1, 2, 3, 4
	NKK (Nippon Kaiji Kyokai)	
TÜV	02ATEX1875 X	
CE	Conformity Marking	



More Information

Detailed references to the approvals are listed in the document "Overview Approvals WAGO-I/O-SYSTEM 750", which You can find on the CD ROM ELECTRONICC Tools and Docs (Item-No.: 0888-0412-0001-0101) or in the Internet under:

www.wago.com -> Service /Downloads /Documentation /WAGO-I/O-SYSTEM 750/System Description/.

Explosion Protection				
Ex directive	94/9/EC EN 50014, EN 50020, EN 50021			
Marking	 II 3 (2) GD EEx na[ib] IIC/IIB T4			
Safety Data electric circuit	U ₀ =27.3 V I ₀ =106 mA P ₀ =723 mW Line characteristic: linear			
Reactance <u>without</u> consideration of the simultaneousness	EEx ia IIC		EEx ia IIB	
	L ₀	C ₀	L ₀	C ₀
	3 mH	88 nF	12 mH	680 nF
Reactance <u>with</u> consideration of the simultaneousness	IIC		IIB	
	L ₀	C ₀	L ₀	C ₀
	≤ 0.2 mH	87 nF	≤ 0.1 mH	0.67 μF
	0.5 mH	68 nF	0.2 mH	0.58 μF
	- mH	- nF	0.5 mH	0.44 μF
	- mH	- nF	1.0 mH	0.36 μF
	- mH	- nF	10.0 mH	0.26 μF

2.1.1.6 Process Image

Output bit	B1	B0
Meaning	controls DO 2 – Channel 2	controls DO 1 – Channel 1

3 Use in Hazardous Environments

3.1 Foreword

Today's development shows that many chemical and petrochemical companies have production plants, production, and process automation machines in operation which use gas-air, vapor-air and dust-air mixtures which can be explosive. For this reason, the electrical components used in such plants and systems must not pose a risk of explosion resulting in injury to persons or damage to property. This is backed by law, directives or regulations on a national and international scale. WAGO-I/O-SYSTEM 750 (electrical components) is designed for use in zone 2 explosive environments. The following basic explosion protection related terms have been defined.

3.2 Protective measures

Primarily, explosion protection describes how to prevent the formation of an explosive atmosphere. For instance by avoiding the use of combustible liquids, reducing the concentration levels, ventilation measures, to name but a few. But there are a large number of applications, which do not allow the implementation of primary protection measures. In such cases, the secondary explosion protection comes into play. Following is a detailed description of such secondary measures.

3.3 Classification meeting CENELEC and IEC

The specifications outlined here are valid for use in Europe and are based on the following standards: EN50... of CENELEC (European Committee for Electrotechnical Standardization). On an international scale, these are reflected by the IEC 60079-... standards of the IEC (International Electrotechnical Commission).

3.3.1 Divisions

Explosive environments are areas in which the atmosphere can potentially become explosive. The term explosive means a special mixture of ignitable substances existing in the form of air-borne gases, fumes, mist or dust under atmospheric conditions which, when heated beyond a tolerable temperature or subjected to an electric arc or sparks, can produce explosions. Explosive zones have been created to describe the concentrations level of an explosive atmosphere. This division, based on the probability of an explosion occurring, is of great importance both for technical safety and feasibility reasons. Knowing that the demands placed on electrical components permanently employed in an explosive environment have to be much more stringent than those placed on electrical components that are only rarely and, if at all, for short periods, subject to a dangerous explosive environment.

Explosive areas resulting from gases, fumes or mist:

- Zone 0 areas are subject to an explosive atmosphere (> 1000 h /year) continuously or for extended periods.
- Zone 1 areas can expect the occasional occurrence of an explosive atmosphere (> 10 h ≤ 1000 h /year).
- Zone 2 areas can expect the rare or short-term occurrence of an explosive atmosphere (> 0 h ≤ 10 h /year).

Explosive areas subject to air-borne dust:

- Zone 20 areas are subject to an explosive atmosphere (> 1000 h /year) continuously or for extended periods.
- Zone 21 areas can expect the occasional occurrence of an explosive atmosphere (> 10 h ≤ 1000 h /year).
- Zone 22 areas can expect the rare or short-term occurrence of an explosive atmosphere (> 0 h ≤ 10 h /year).

3.3.2 Explosion protection group

In addition, the electrical components for explosive areas are subdivided into two groups:

Group I: Group I includes electrical components for use in fire-damp endangered mine structures.

Group II: Group II includes electrical components for use in all other explosive environments. This group is further subdivided by pertinent combustible gases in the environment. Subdivision IIA, IIB and IIC takes into account that different materials/substances/gases have various ignition energy characteristic values. For this reason the three sub-groups are assigned representative types of gases:

- IIA – Propane
- IIB – Ethylene
- IIC – Hydrogen

Minimal ignition energy of representative types of gases				
Explosion group	I	IIA	IIB	IIC
Gases	Methane	Propane	Ethylene	Hydrogen
Ignition energy (μJ)	280	250	82	16

Hydrogen being commonly encountered in chemical plants, frequently the explosion group IIC is requested for maximum safety.

3.3.3 Unit categories

Moreover, the areas of use (zones) and the conditions of use (explosion groups) are subdivided into categories for the electrical operating means:

Unit categories	Explosion group	Area of use
M1	I	Fire-damp protection
M2	I	Fire-damp protection
1G	II	Zone 0 Explosive environment by gas, fumes or mist
2G	II	Zone 1 Explosive environment by gas, fumes or mist
3G	II	Zone 2 Explosive environment by gas, fumes or mist
1D	II	Zone 20 Explosive environment by dust
2D	II	Zone 21 Explosive environment by dust
3D	II	Zone 22 Explosive environment by dust

3.3.4 Temperature classes

The maximum surface temperature for electrical components of explosion protection group I is 150 °C (danger due to coal dust deposits) or 450 °C (if there is no danger of coal dust deposit).

In line with the maximum surface temperature for all ignition protection types, the electrical components are subdivided into temperature classes, as far as electrical components of explosion protection group II are concerned. Here the temperatures refer to a surrounding temperature of 40 °C for operation and testing of the electrical components. The lowest ignition temperature of the existing explosive atmosphere must be higher than the maximum surface temperature.

Temperature classes	Maximum surface temperature	Ignition temperature of the combustible materials
T1	450 °C	> 450 °C
T2	300 °C	> 300 °C to 450 °C
T3	200 °C	> 200 °C to 300 °C
T4	135 °C	> 135 °C to 200 °C
T5	100 °C	>100 °C to 135 °C
T6	85°C	> 85 °C to 100 °C

The following table represents the division and attributes of the materials to the temperature classes and material groups in percent:

Temperature classes						
T1	T2	T3	T4	T5	T6	Total*
26.6 %	42.8 %	25.5 %				
94.9 %			4.9 %	0 %	0.2 %	432
Explosion group						
IIA	IIB	IIC				Total*
85.2 %	13.8 %	1.0 %				501

* Number of classified materials

3.3.5 Types of ignition protection

Ignition protection defines the special measures to be taken for electrical components in order to prevent the ignition of surrounding explosive atmospheres. For this reason a differentiation is made between the following types of ignition protection:

Identifi- cation	CENELEC standard	IEC standard	Explanation	Application
EEx o	EN 50 015	IEC 79-6	Oil encapsulation	Zone 1 + 2
EEx p	EN 50 016	IEC 79-2	Overpressure encapsulation	Zone 1 + 2
EEx q	EN 50 017	IEC 79-5	Sand encapsulation	Zone 1 + 2
EEx d	EN 50 018	IEC 79-1	Pressure resistant encapsulation	Zone 1 + 2
EEx e	EN 50 019	IEC 79-7	Increased safety	Zone 1 + 2
EEx m	EN 50 028	IEC 79-18	Cast encapsulation	Zone 1 + 2
EEx i	EN 50 020 (unit) EN 50 039 (system)	IEC 79-11	Intrinsic safety	Zone 0 + 1 + 2
EEx n	EN 50 021	IEC 79-15	Electrical components for zone 2 (see below)	Zone 2

Ignition protection “n” describes exclusively the use of explosion protected electrical components in zone 2. This zone encompasses areas where explosive atmospheres can only be expected to occur rarely or short-term. It represents the transition between the area of zone 1, which requires an explosion protection and safe area in which for instance welding is allowed at any time.

Regulations covering these electrical components are being prepared on a world-wide scale. The standard EN 50 021 allows electrical component manufacturers to obtain certificates from the corresponding authorities for instance KEMA in the Netherlands or the PTB in Germany, certifying that the tested components meet the above mentioned standards draft.

Type “n” ignition protection additionally requires electrical components to be marked with the following extended identification:

- A – non spark generating (function modules without relay /without switches)
- AC – spark generating, contacts protected by seals (function modules with relays / without switches)
- L – limited energy (function modules with switch)



Further information

For more detailed information please refer to the national and/or international standards, directives and regulations!

3.4 Classifications meeting the NEC 500

The following classifications according to NEC 500 (National Electric Code) are valid for North America.

3.4.1 Divisions

The "Divisions" describe the degree of probability of whatever type of dangerous situation occurring. Here the following assignments apply:

Explosion endangered areas due to combustible gases, fumes, mist and dust:	
Division 1	Encompasses areas in which explosive atmospheres are to be expected occasionally (> 10 h ≤ 1000 h /year) as well as continuously and long-term (> 1000 h /year).
Division 2	Encompasses areas in which explosive atmospheres can be expected rarely and short-term (>0 h ≤ 10 h /year).

3.4.2 Explosion protection groups

Electrical components for explosion endangered areas are subdivided in three danger categories:

Class I (gases and fumes):	Group A (Acetylene) Group B (Hydrogen) Group C (Ethylene) Group D (Methane)
Class II (dust):	Group E (Metal dust) Group F (Coal dust) Group G (Flour, starch and cereal dust)
Class III (fibers):	No sub-groups

3.4.3 Temperature classes

Electrical components for explosive areas are differentiated by temperature classes:

Temperature classes	Maximum surface temperature	Ignition temperature of the combustible materials
T1	450 °C	> 450 °C
T2	300 °C	> 300 °C to 450 °C
T2A	280 °C	> 280 °C to 300 °C
T2B	260 °C	> 260 °C to 280 °C
T2C	230 °C	>230 °C to 260 °C
T2D	215 °C	>215 °C to 230 °C
T3	200 °C	>200 °C to 215 °C
T3A	180 °C	>180 °C to 200 °C
T3B	165 °C	>165 °C to 180 °C
T3C	160 °C	>160 °C to 165 °C
T4	135 °C	>135 °C to 160 °C
T4A	120 °C	>120 °C to 135 °C
T5	100 °C	>100 °C to 120 °C
T6	85 °C	> 85 °C to 100 °C

3.5 Identification

3.5.1 For Europe

According to CENELEC and IEC

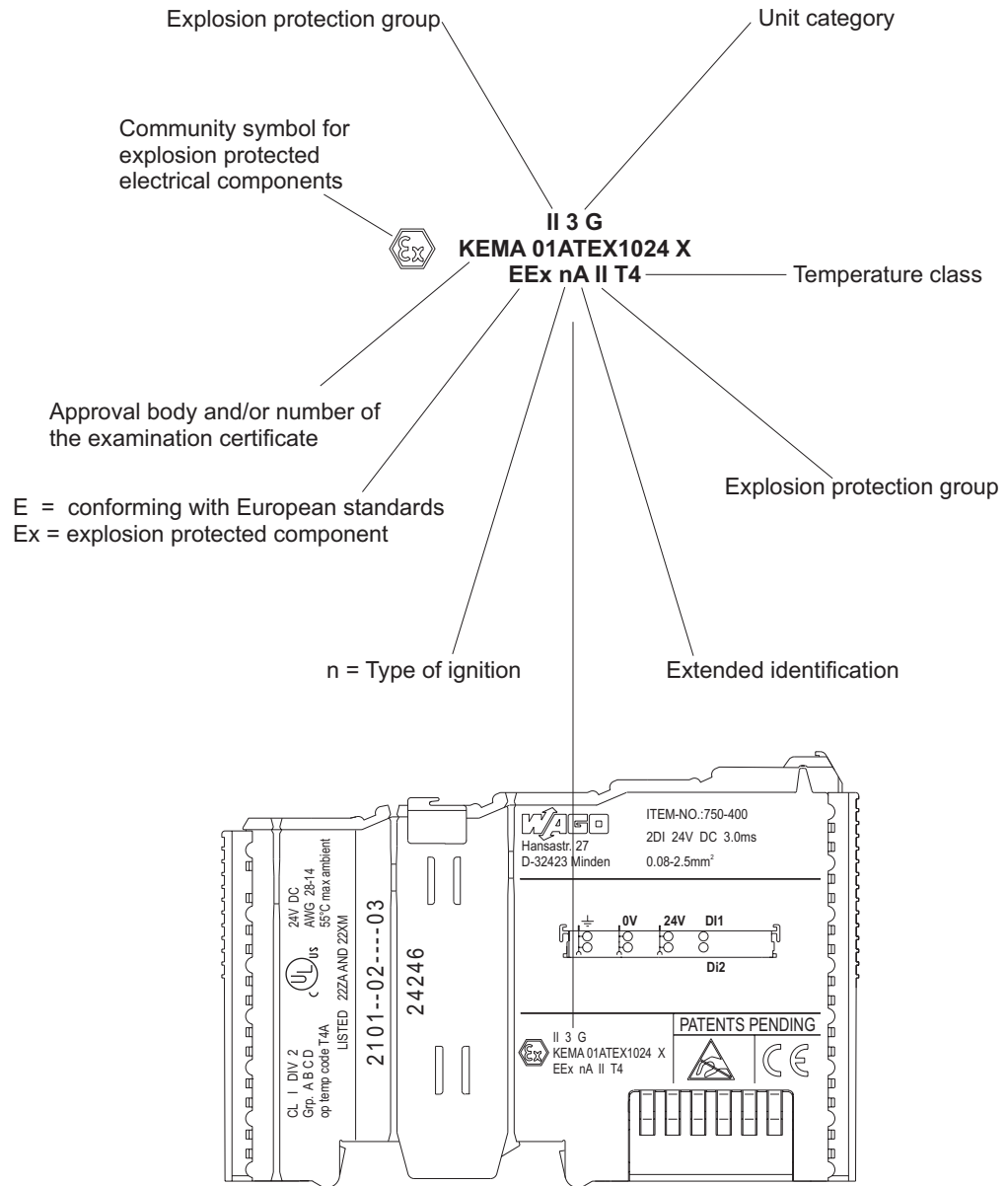

Fig. 3.5.1-1: Example for lateral labeling of bus modules
(750-400, 2 channel digital input module 24 V DC)

g01xx03e

3.5.2 For America

According to NEC 500

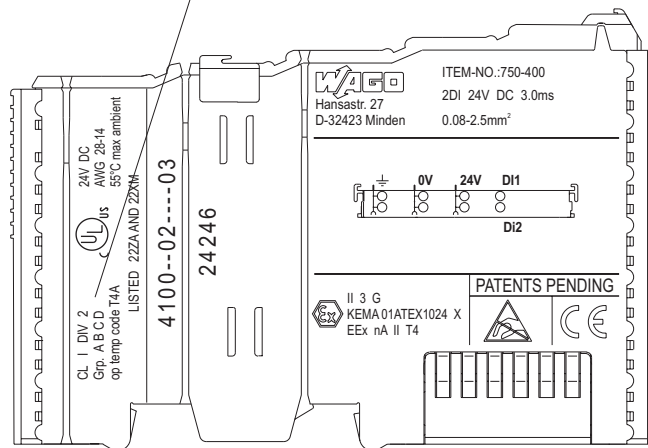
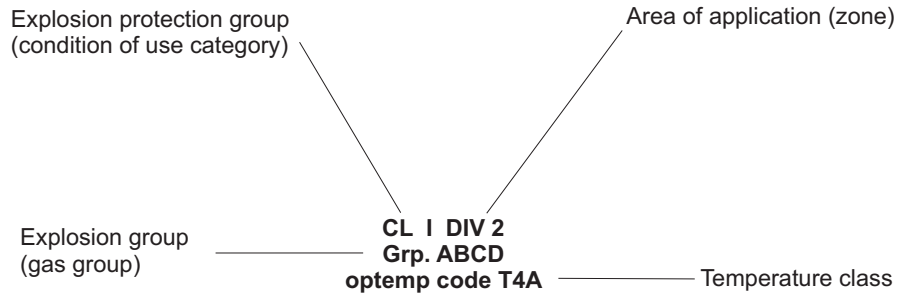

Fig. 3.5.2-1: Example for lateral labeling of bus modules
(750-400, 2 channel digital input module 24 V DC)

g01xx04e

3.6 Installation regulations

In the **Federal Republic of Germany**, various national regulations for the installation in explosive areas must be taken into consideration. The basis being the ElexV complemented by the installation regulation DIN VDE 0165/2.91. The following are excerpts from additional VDE regulations:

DIN VDE 0100	Installation in power plants with rated voltages up to 1000 V
DIN VDE 0101	Installation in power plants with rated voltages above 1 kV
DIN VDE 0800	Installation and operation in telecommunication plants including information processing equipment
DIN VDE 0185	lightning protection systems

The **USA** and **Canada** have their own regulations. The following are excerpts from these regulations:

NFPA 70	National Electrical Code Art. 500 Hazardous Locations
ANSI/ISA-RP 12.6-1987	Recommended Practice
C22.1	Canadian Electrical Code



Danger

When using the WAGO-I/O SYSTEM 750 (electrical operation) with Ex approval, the following points are mandatory:

- A. The fieldbus independent I/O System Modules Type 750-xxx are to be installed in enclosures that provide for the degree of ingress protection of at least IP54.
For use in the presence of combustible dust, the above mentioned modules are to be installed in enclosures that provide for the degree of ingress protection of at least IP64.
 - B. The fieldbus independent I/O system may only be installed in hazardous areas (Europe: Group II, Zone 2 or America: Class I, Division 2, Group A, B, C, D) or in non-hazardous areas!
 - C. Installation, connection, addition, removal or replacement of modules, fieldbus connectors or fuses may only take place when the system supply and the field supply are switched off, or when the area is known to be non-hazardous.
 - D. Ensure that only approved modules of the electrical operating type will be used. The Substitution or Replacement of modules can jeopardize the suitability of the system in hazardous environments!
 - E. Operation of intrinsically safe EEx i modules with direct connection to sensors/actuators in hazardous areas of Zone 0 + 1 and Division 1 type requires the use of a 24 V DC Power Supply EEx i module!
 - F. DIP switches and potentiometers are only to be adjusted when the area is known to be non-hazardous.
-



Further Information

Proof of certification is available on request. Also take note of the information given on the module technical information sheet.



WAGO Kontakttechnik GmbH & Co. KG
Postfach 2880 • D-32385 Minden
Hansastraße 27 • D-32423 Minden
Phone: 05 71/8 87 – 0
Fax: 05 71/8 87 – 1 69
E-Mail: info@wago.com

Internet: <http://www.wago.com>
