

WAGO → I/O → SYSTEM 750

**Fieldbus Independent
I/O Modules**

**Serial Interface RS 232 C
750-650 (/xxx-xxx)**



Manual

Version 1.0.2

Copyright © 2006 by WAGO Kontakttechnik GmbH & Co. KG
All rights reserved.

WAGO Kontakttechnik GmbH & Co. KG

Hansastraße 27
D-32423 Minden

Phone: +49 (0) 571/8 87 – 0
Fax: +49 (0) 571/8 87 – 1 69
E-Mail: info@wago.com
Web: <http://www.wago.com>

Technical Support

Phone: +49 (0) 571/8 87 – 5 55
Fax: +49 (0) 571/8 87 – 85 55
E-Mail: support@wago.com

Every conceivable measure has been taken to ensure the correctness and completeness of this documentation. However, as errors can never be fully excluded, we would appreciate any information or ideas at any time.

E-Mail: documentation@wago.com

We wish to point out that the software and hardware terms as well as the trademarks of companies used and/or mentioned in the present manual are generally trademark or patent protected.

CONTENT

1 Important Comments	4
1.1 Legal Principles	4
1.1.1 Copyright	4
1.1.2 Personnel Qualification	4
1.1.3 Intended Use	4
1.2 Symbols	5
1.3 Number Notation	5
1.4 Safety Notes	6
1.5 Scope	6
2 I/O Modules	7
2.1 Special Modules	7
2.1.1 750-650 (/xxx-xxx) [Serial Interface RS 232 C]	7
2.1.1.1 View	7
2.1.1.2 Variations	7
2.1.1.3 Description	8
2.1.1.4 Display Elements	10
2.1.1.5 Schematic Diagram	10
2.1.1.6 Technical Data	11
2.1.1.7 Functional description	12
2.1.1.8 Process Image	13
2.1.1.9 Datatransfer	15
2.1.1.9.1 Example	16
2.1.1.10 Adjustable Variation 750-650/003-000	19

1 Important Comments

To ensure fast installation and start-up of the units described in this manual, we strongly recommend that the following information and explanations are carefully read and abided by.

1.1 Legal Principles

1.1.1 Copyright

This manual is copyrighted, together with all figures and illustrations contained therein. Any use of this manual which infringes the copyright provisions stipulated herein, is not permitted. Reproduction, translation and electronic and photo-technical archiving and amendments require the written consent of WAGO Kontakttechnik GmbH & Co. KG. Non-observance will entail the right of claims for damages.

WAGO Kontakttechnik GmbH & Co. KG reserves the right to perform modifications allowed by technical progress. In case of grant of a patent or legal protection of utility patents all rights are reserved by WAGO Kontakttechnik GmbH & Co. KG. Products of other manufacturers are always named without referring to patent rights. The existence of such rights can therefore not be ruled out.

1.1.2 Personnel Qualification

The use of the product detailed in this manual is exclusively geared to specialists having qualifications in PLC programming, electrical specialists or persons instructed by electrical specialists who are also familiar with the valid standards. WAGO Kontakttechnik GmbH & Co. KG declines all liability resulting from improper action and damage to WAGO products and third party products due to non-observance of the information contained in this manual.

1.1.3 Intended Use

For each individual application, the components supplied are to work with a dedicated hardware and software configuration. Modifications are only permitted within the framework of the possibilities documented in the manuals. All other changes to the hardware and/or software and the non-conforming use of the components entail the exclusion of liability on part of WAGO Kontakttechnik GmbH & Co. KG.

Please direct any requirements pertaining to a modified and/or new hardware or software configuration directly to WAGO Kontakttechnik GmbH & Co. KG.

1.2 Symbols



Danger

Always abide by this information to protect persons from injury.



Warning

Always abide by this information to prevent damage to the device.



Attention

Marginal conditions must always be observed to ensure smooth operation.



ESD (Electrostatic Discharge)

Warning of damage to the components by electrostatic discharge. Observe the precautionary measure for handling components at risk.



Note

Routines or advice for efficient use of the device and software optimization.



More information

References on additional literature, manuals, data sheets and INTERNET pages

1.3 Number Notation

Number Code	Example	Note
Decimal	100	normal notation
Hexadecimal	0x64	C notation
Binary	'100' '0110.0100'	Within ', Nibble separated with dots

1.4 Safety Notes



Warning

Switch off the system prior to working on bus modules!

In the event of deformed contacts, the module in question is to be replaced, as its functionality can no longer be ensured on a long-term basis.

The components are not resistant against materials having seeping and insulating properties. Belonging to this group of materials is: e.g. aerosols, silicones, triglycerides (found in some hand creams).

If it cannot be ruled out that these materials appear in the component environment, then additional measures are to be taken:

- installation of the components into an appropriate enclosure
 - handling of the components only with clean tools and materials.
-



Attention

Cleaning of soiled contacts may only be done with ethyl alcohol and leather cloths. Thereby, the ESD information is to be regarded.

Do not use any contact spray. The spray may impair the functioning of the contact area.

The WAGO-I/O-SYSTEM 750 and its components are an open system. It must only be assembled in housings, cabinets or in electrical operation rooms. Access must only be given via a key or tool to authorized qualified personnel.

The relevant valid and applicable standards and guidelines concerning the installation of switch boxes are to be observed.



ESD (Electrostatic Discharge)

The modules are equipped with electronic components that may be destroyed by electrostatic discharge. When handling the modules, ensure that the environment (persons, workplace and packing) is well grounded. Avoid touching conductive components, e.g. gold contacts.

1.5 Scope

This manual describes the Digital Input Module 750-650 (/xxx-xxx) Serial Interface RS 232 C of the modular WAGO-I/O-SYSTEM 750.

Handling, assembly and start-up are described in the manual of the Fieldbus Coupler. Therefore this documentation is valid only in the connection with the appropriate manual.

2 I/O Modules

2.1 Special Modules

2.1.1 750-650 (/xxx-xxx) [Serial Interface RS 232 C]

2.1.1.1 View

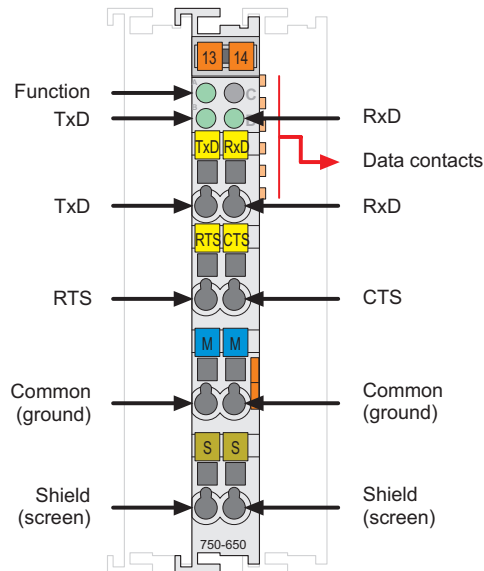

Fig. 2.1.1-1: Serial Interface 750-650

g065000e

2.1.1.2 Variations

Item-No.	Designation	Description
750-650	RS 232 C/ 9600/ N/ 8/ 1	Baud rate: 9600 baud; Parity: none; data bits: 8, stop bits: 1
750-650/000-001	RS 232 C/ 9600/ N/ 8/ 1/ 5 byte	Baud rate: 9600 baud; Parity: none; data bits: 8, stop bits: 1, user data: 5 byte
750-650/000-002	RS 232 C/ 9600/ E/ 7/ 1	Baud rate: 9600 baud; Parity: Even; data bits: 7, stop bits: 1
750-650/000-004	RS 232 C/ 4800/ E/ 7/ 1	Baud rate: 4800 baud; Parity: Even; data bits: 7, stop bits: 1
750-650/000-006	RS 232 C/ 9600/ E/ 8/ 1	Baud rate: 9600 baud; Parity: Even; data bits: 8, stop bits: 1
750-650/000-009	RS 232 C/ 2400/ E/ 8/ 1	Baud rate: 2400 baud; Parity: Even; data bits: 8, stop bits: 1
750-650/000-010	RS 232 C/ 19200/ N/ 8/ 1	Baud rate: 19200 baud; Parity: None; data bits: 8, stop bits: 1
750-650/000-011	RS 232 C/ 19200/ E/ 8/ 1	Baud rate: 19200 baud; Parity: Even; data bits: 8, stop bits: 1
750-650/000-012	RS 232 C/ 2400/ N/ 8/ 1	Baud rate: 2400 baud; Parity: None; data bits: 8, stop bits: 1

Item-No.	Designation	Description
750-650/000-013	RS 232 C/ 4800/ E/ 7/ 2	Baud rate: 4800 baud; Parity: Even; data bits: 7, stop bits: 2
750-650/000-014	RS 232 C/ 2400/ E/ 7/ 2	Baud rate: 2400 baud; Parity: Even; data bits: 7, stop bits: 2
750-650/000-015	RS 232 C/ 4800/ E/ 8/ 1	Baud rate: 4800 baud; Parity: Even; data bits: 8, stop bits: 1
750-650/000-016	RS 232 C/ 9600/ O/ 7/ 2/ 5 byte	Baud rate: 9600 baud; Parity: Odd; data bits: 7, stop bits: 2, user data: 5 byte
750-650/003-000	RS 232 C	Baud rate and handshake parameterizable with WAGO-I/O-CHECK 2

2.1.1.3 Description

This interface allows the connection of any device which is equipped with a RS 232 C serial interface.

The wiring to the communication partner is made by the connections TxD, RxD, if necessary RTS and CTS as well as ground (earth).
The shield (screen) is directly connected to the carrier rail.

The interface works in accordance with the TIA/EIA-232-F, CCITT V.28/DIN 66259-1 standard.

The connected device may directly communicate over the fieldbus coupler/-controller with the control unit. The active communication channel works independently of the higher-level fieldbus system and allows full duplex operation up to 19200 baud.

Three green LEDs signal readiness for operation and troublefree internal bus communication as well as the condition of the signal transmission.

The RS 232 interface guarantees high interference immunity because of the electrically isolated signals.

Any configuration of the specialty modules is possible when designing the fieldbus node. Grouping of module types is not necessary.



Attention

This module has no power contacts. For field supply to downstream I/O modules, a supply module will be needed.

The serial interface module 750-650 and its variations can be used with all couplers/controllers of the WAGO-I/O-SYSTEM 750 (except for the economy types 750-320, -323, -324 and -327).

This description is valid from hardware and software version XXXX4108... and up. The version is specified in the manufacturing number, which is part of the lateral marking on the module.

2.1.1.4 Display Elements

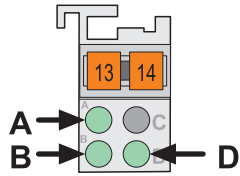

Fig. 2.1.1-2: Display Elements g065002x

LED	Channel	State	Function
A green	Function	off	No operational readiness or the internal data bus communication is interrupted
		on	Operational readiness and trouble-free internal data bus communication
B green	TxD	off ¹⁾	signal transfer TxD
		on	no signal transfer TxD
D green	RxD	off ¹⁾	signal transfer RxD
		on	no signal transfer RxD or open input

¹⁾ The pulses are so short that the off status cannot or only hardly be recognized with the eyes.

2.1.1.5 Schematic Diagram

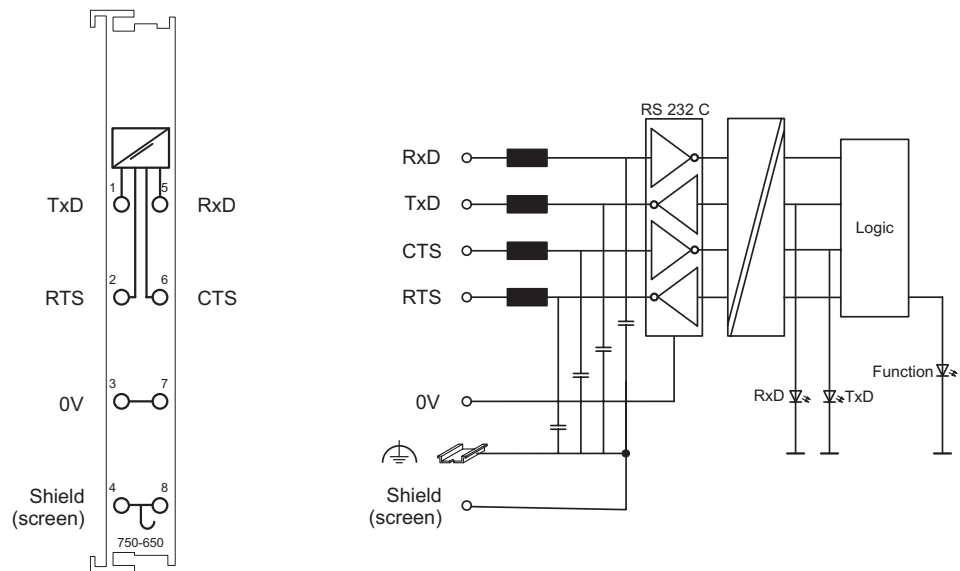













Fig. 2.1.1-3: Serial Interface 750-650

g065001e

2.1.1.6 Technical Data

Module Specific Data		
Transmission channel	1 TxD / 1 RxD, full duplex	
Baud rate	1200 ... 19200 baud	
Bit skew	< 3 %	
Current consumption	max. 55 mA	
RS 232 C-line length	max. 15 m	
Buffer	120 byte in / 16 byte out	
Voltage supply	via system voltage DC /DC	
Isolation	500 V (System/Supply)	
Bit width	1 x 40 bits data 1 x 8 bits control/status	
Dimensions (mm) W x H x L	12 x 64* x 100 * from upper edge of 35 DIN rail	
Weight	ca. 55 g	
Standards and Regulations (cf. Chapter 2.2 of the Coupler/Controller Manual)		
EMC-Immunity to interference (CE)	acc. to EN 50082-2 (96)	
EMC-Emission of interference (CE)	acc. to EN 50081-1 (93)	
EMC-Immunity to interference (Ship building)	acc. to Germanischer Lloyd (01)	
EMC-Emission of interference (Ship building)	acc. to Germanischer Lloyd (01)	
Approvals (cf. Chapter 2.2 of the Coupler/Controller Manual)		
	cUL _{US} (UL508)	
	ABS (American Bureau of Shipping)	
	BV (Bureau Veritas)	
	DNV (Det Norske Veritas)	Cl. B
	GL (Germanischer Lloyd)	Cat. A, B, C, D
	KR (Korean Register of Shipping)	
	LR (Lloyd's Register)	Env. 1, 2, 3, 4
	NKK (Nippon Kaiji Kyokai)	
	RINA (Registro Italiano Navale)	(only for 750-650)
	cUL _{US} (UL1604)	Class I Div2 ABCD T4A
	KEMA	II 3 G EEx nA II T4
	Conformity Marking	



More Information

Detailed references to the approvals are listed in the document "Overview Approvals WAGO-I/O-SYSTEM 750", which you can find on the CD ROM ELECTRONIC Tools and Docs (Item-No.: 0888-0412)

or in the internet under:

www.wago.com → Documentation → WAGO-I/O-SYSTEM 750 → System Description

2.1.1.7 Functional description

The interface module is designed to operate with all WAGO I/O fieldbus couplers. The serial interface module allows the connection of RS 232-Interface devices to the WAGO I/O SYSTEM. The RS 232 Interface module can provide gateways within the fieldbus protocol. This allows serial equipment such as printers, barcode readers, and links to local operator interfaces to communicate directly by the fieldbus protocol with the PLC or PC Master. This module supports no higher level of protocol. Communication is made completely transparent to the fieldbus allowing flexibility in further applications of the serial interface module. The communication protocols are configured at the Master PLC or PC.

The 120 byte input buffer provides for high rates of data transmission. When using lower rates of transmission speed you can collect the received data, with less priority, without losing data.

The 16 byte output buffer provides for faster transmission of larger data strings.



Attention

The data transmission takes place at 9.600 baud. 1 startbit, 8 databits and 1 stopbit will be transmitted. No parity is available. The user controls data via the RTS and CTS signals. These signals are generated in the module depending on the loading status of the buffers. These controls can be deactivated by means of an external jumper. RTS and CTS are to be connected.



Attention

For testing purposes the Windows terminal emulation  Terminal can be used. A cable with a 9- pole sub-D socket is required. Pin 5 is connected to input "common". Pin 2 is connected to TxD and Pin 3 to RxD. RTS and CTS of the module are connected. A hardwarehandshake between the terminal emulation and the PLC is not possible.

2.1.1.8 Process Image

Using the I/O module 750-650, a 6 byte input and output process image can be transferred to the fieldbus coupler / controller via one logical channel. The transfer of the data to be transmitted and the received data is made via 5 output and 5 input bytes (D0 ... D4). 1 Control byte (C) and 1 Status byte (S) are used to control the floating data.



Attention

The representation of the process data of some I/O modules or their variations in the process image depends on the fieldbus coupler/-controller used. Please take this information as well as the particular design of the respective control/status bytes from the section "Fieldbus Specific Design of the Process Data" included in the description concerning the process image of the corresponding coupler/controller.

Up to 5 characters which have been received via interface can be stored in the input bytes. The output bytes will contain the characters to be sent.

Input data		Output data	
S	Status byte	C	Control byte
D0	Input byte 0	D0	Output byte 0
D1	Input byte 1	D1	Output byte 1
D2	Input byte 2	D2	Output byte 2
D3	Input byte 3 *) , **)	D3	Output byte 3 *) , **)
D4	Input byte 4 **)	D4	Output byte 4 **)

*) with variations with 4 Data bytes, **) with variations with 5 Data bytes

Control byte							
Bit 7	Bit 6	Bit 5	Bit 4	Bit 3	Bit 2	Bit 1	Bit 0
0	OL 2	OL 1	OL 0	0	IR	RA	TR

TR Transmit request

RA Receive acknowledge

IR Initialization request

OL 0, OL 1, OL 2 Output length (number of characters to be sent, which have been stored in the output bytes)

0 Constant value must always be 0.

Status byte							
Bit 7	Bit 6	Bit 5	Bit 4	Bit 3	Bit 2	Bit 1	Bit 0
0	IL 2	IL 1	IL 0	BUF_F	IA	RR	TA

TA Transmit acknowledge

RR Receive request

IA Initialization acknowledge

BUF_F Buffer full

IL 0,
IL 1,
IL 2 Input length (number of received characters , which have been stored in the
input data)

0 Constant value must always be 0.

2.1.1.9 Datatransfer

With the control and status byte the controlling of the sending and receive mode takes place. Requests are indicated by a bit change of state. An assigned bit indicates execution by adopting the value of the request bit.

Initialization of the module:

- Set IR bit in the control byte
- Initialization of the module
- Transmit/receive functions are blocked
- Output/input buffers are erased
- Serial interface module will load its configuration data

Transmitting data:

- TR=TA: put characters into output bytes 0 to 2
- Amount of characters is specified in OL0 to OL2
- TR is inverted and read out
- characters are put into output buffer if TR=TA

Receiving data:

- RR≠RA: data in input bytes 0 to 2 characters are available
- Amount of characters is specified in IL0 to IL2
- Characters in IL0 to IL2 are read out
- RA is inverted and read out
- All characters are read when RR=RA

The transmitting and receiving of data can be done simultaneously. The initialization request has priority and will stop transmitting and receiving of data immediately.



Attention

Resetting the initialization bit can be performed with the following message.

Message: input buffer full (Bit 3)

Input buffer is full. Data which is being currently received is now lost.

2.1.1.9.1 Example

The module is initialized.

The initialization bit in the control byte is set.

Output byte 0	Control byte	Output byte 2	Output byte 1
0x00	'0000.0100'	0x00	0x00

After the initialization has been executed, the status byte will give back 000.0100.

Input byte 0	Status byte	Input byte 2	Input byte 1	
XX	'0XXX.X0XX'	XX	XX	Module is still being reset.
XX	'0XXX.X1XX'	XX	XX	Initialization completed.

Sending of the data string "Hello"

The first 3 characters and the buffer length of 3 are transmitted.

Output byte 0	Control byte	Output byte 2	Output byte 1
"H" (0x48)	'0011.0000'	"l" (0x6C)	"a" (0x60)

The transmission request bit (TR) is inverted.

Output byte 0	Control byte	Output byte 2	Output byte 1
"H"	'0011.0001'	"l"	"a"

As soon as TR=TA, the rest of the data can be sent.

Input byte 0	Status byte	Input byte 2	Input byte 1	
XX	'0XXX.XXX0'	XX	XX	The data is still being transferred.
XX	'0XXX.XXX1'	XX	XX	Data transfer completed.

The last 2 characters and the buffer length of 2 are transmitted.

Output byte 0	Control byte	Output byte 2	Output byte 1
"1"	'0010.0001'	XX	"o" (0x6F)

The transmission request bit (TR) is inverted.

Output byte 0	Control byte	Output byte 2	Output byte 1
"1"	'0010.0000'	XX	"o"

As soon as TA = TR, the data has been transferred to the output buffer.

Input byte 0	Status byte	Input byte 2	Input byte 1	
XX	'0XXX. XXX1'	XX	XX	The data is still being transferred.
XX	'0XXX. XXX0'	XX	XX	Data transfer completed.

Receiving the character chain "WAGO"

As soon as RA≠RR, the input bytes contain data.

Output byte 0	Control byte	Output byte 2	Output byte 1
XX	'0XXX.000X'	XX	XX

Input byte 0	Status byte	Input byte 2	Input byte 1	
XX	'0XXX. 0X0X'	XX	XX	No received data available.
"W"	'0011.0X1X'	"G"	"A"	The information is in the input bytes.

After the 3 characters have been processed, RA is inverted.

Output byte 0	Control byte	Output byte 2	Output byte 1
XX	'0XXX.001X'	XX	XX

If $RA \neq RR$, the receiving of additional characters will continue.

Input byte 0	Status byte	Input byte 2	Input byte 1	
XX	'0XXX.0X1X'	XX	XX	No received data available.
'0'	'0001.0X0X'	XX	XX	The information is in the input bytes.

After the characters have been processed, RA is inverted.

Output byte 0	Control byte	Output byte 2	Output byte 1
XX	'0XXX.000X'	XX	XX



Note

An X indicates that this particular value has no importance.
XX indicates that the whole value has no importance.

2.1.1.10 Adjustable Variation 750-650/003-000

The serial interface module 750-650/003-000 may be parameterized with the software tool **WAGO-I/O-CHECK 2** (Item-No.: 759-302).

The presetting is Baud rate: 9600 baud, data bits: 8, Parity: none, stop bits: 1. In this mode of operation the module has the same behavior and also the same process values as the base module 750-650. If another mode of operation is selected by changing the parameters, then the module behaves according to the variation with the selected mode of operation.

The parameter dialog box in **WAGO I/O CHECK 2** offers selection fields for the available settings of this I/O module.

The following description is valid for software version 41.

Select box	Available settings	
Baudrate	1200 Baud / 2400 Baud / 4800 Baud / 9600 Baud* / 19200 Baud / 38400 Baud / 57600 Baud	
Data frame	7 Data bits, Even Parity / 7 Data bits, Odd Parity / 8 Data bits, No Parity* / 8 Data bits, Even Parity / 8 Data bits, Odd Parity	
Stop bits	1* / 2	Number of stop bits
Output format	Standard	(see mapping-tables in the coupler- / controller-manual)
	Alternative*	(see mapping-tables in the coupler- / controller-manual)
Data bytes (BK)	3* / 4 / 5	Number of data bytes (see mapping-tables in the coupler- / controller-manual)
RTS / CTS	Disable	Hardware handshake is not active
	Enable*	Hardware handshake is active RTS is set if receive buffer of the module contains more than 114 characters. RTS is reset if receive buffer of the module contains less than 104 characters. If CTS is set the module does not send any data.
Copy State Byte	Normal*	State byte and data bytes are transmitted in the same KBUS cycle
	Retarded	The state byte is transmitted one KBUS cycle later after data bytes are transmitted. This causes a lower data transmission rate.
XON / XOFF (send)	OFF*	The module does not support the XON/XOFF-protocol when sending data.

Select box	Available settings	
	ON	The module supports the XON/XOFF-protocol when sending data. The module sends the data delivered by the PLC until the XOFF (DC3==0x13) character is received from the communication partner. The transmission is halted until the XON (DC1==0x11) character is received.
XON / XOFF (receive)	OFF*	The module does not support the XON/XOFF-protocol when receiving data.
	ON	The module supports the XON/XOFF-protocol when receiving data. The module sends the XOFF control character if the receive buffer contains more than 110 characters. XON is sent once XOFF has been sent and the buffer contains less than 18 bytes.
Continuous Send	OFF*	Continuous data transmission from FIFO is not active.
	ON	Continuous data transmission from FIFO is active. The send buffer is filled by the PLC (up to 16 bytes). The buffer content is sent with the rising edge in bit 3 of the control byte. Acknowledgement of the transmitted data is done by setting the bit 2 of the status byte. Bit 2 of the status byte is reset when bit 3 of the control byte is set.

* default setting



More Information

Detailed Information about the parameterizing this module can be found in the manual for the software tool **WAGO-I/O-CHECK 2** or in the Internet under: www.wago.com.



WAGO Kontakttechnik GmbH & Co. KG
Postfach 2880 • D-32385 Minden
Hansastraße 27 • D-32423 Minden
Phone: 05 71/8 87 – 0
Fax: 05 71/8 87 – 1 69
E-Mail: info@wago.com

Internet: <http://www.wago.com>