

WAGO → I/O → SYSTEM *752*

Fieldbus Dependent I/O Module

CANopen

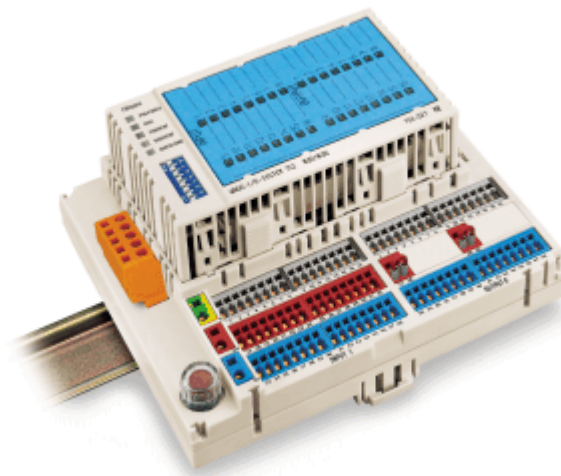

Manual

Technical Description,
Installation and
Configuration

752-124/000-002
Version 1.0.0

Copyright © 2001 by WAGO Kontakttechnik GmbH
All rights reserved.

WAGO Kontakttechnik GmbH

Hansastraße 27
D-32423 Minden

Ph.: +49 (0) 571/8 87 – 0
Fax: +49 (0) 571/8 87 – 1 69

E-mail: info@wago.com

Web: <http://www.wago.com>

Technical Support

Ph.: +49 (0) 571/8 87 – 5 55
Fax: +49 (0) 571/8 87 – 4 30

E-mail: support@wago.com

Every conceivable measure has been taken to ensure the correctness and completeness of this documentation. However, as errors can never be fully excluded we would appreciate any information or ideas at any time.

We expressively point out that the software and hardware designations and brand names of individual companies used in this manual are subject to general trade name, trademark or patent protection.

Table of Contents

1	Important Explanations.....	1
1.1	Legal Basis	1
1.1.1	Copyright	1
1.1.2	Personnel Qualification.....	1
1.1.3	Intended Use	1
1.2	Scope of Validity.....	2
1.3	Symbols.....	2
1.4	Abbreviations	3
2	System Description.....	4
2.1	Base Module.....	5
2.2	Electronic Module	6
3	Technical Data	7
4	Installation	12
4.1	Mechanical Installation	12
4.1.1	Snapping on / Detaching the Base Module.....	12
4.1.2	Insertion/Extraction of the Electronic Module.....	13
4.1.3	Marking Label.....	13
4.1.4	DIP Switch	14
4.2	Electrical Installation.....	16
4.2.1	General	16
4.2.2	Connection of the Module Supply Voltage.....	17
4.2.3	Connection of the Input Signals.....	18
4.2.4	Connection of the Output Supply Voltage.....	19
4.2.5	Connection of the Output Signals	20
4.2.6	Connection of the Fieldbus Interface	21
4.2.7	Cabling of the Fieldbus	22
5	Schematic Circuit Diagram.....	24
6	Status Indicators.....	25
6.1	Input Status Indicators.....	25
6.2	Output Status Indicators	26
6.3	Fieldbus Interface Status Indicators	26
6.4	Overload Status Indicator.....	27

7	CANopen	28
7.1	Review.....	28
7.2	Module properties	29
7.3	Object Directory.....	30
7.3.1	Communication Profile Area	30
7.3.2	Manufacturer Specific Device Profile.....	32
7.3.3	Standard Device Profile	33
7.3.4	Relation (Standard Mapping).....	34
7.3.5	Transmission Type (Operating mode)	36
7.3.6	Inhibit Time.....	36
7.3.7	Setting the COB-IDs	37
7.3.8	Error messages (Emergency)	38
7.3.9	Device Type, Index 0x1000	40
7.3.10	Pre-defined Error Field, Index 0x1003	41
7.3.11	Communication Cycle Period, Index 0x1006	41
7.3.12	Store Parameter, Index 0x1010	42
7.3.13	Load Parameter, Index 0x1011	42
7.3.14	SYNC Guarding.....	43
7.3.15	Node Guarding.....	43
7.3.16	Diagnosis of the Outputs, Index 0x5900.....	44
7.3.17	Error Mode, Index 0x6206 and Error Value, Index 0x6207	45
7.3.18	Error Behavior, Index 0x67FE.....	46
7.4	CANopen Telegrams.....	47
7.5	PDO Mapping	51
7.5.1	The Indices of the PDO Mapping	52
7.6	Example PDO Mapping	53
7.7	Default Process Data Input Image.....	56
7.8	Default Process Data Output Image.....	56
7.9	EDS files	56
7.10	Configuration	57
7.11	Fieldbus Controller Boards	57
7.12	Configuration Software	57
8	Accessories	58

1 Important Explanations

To allow the user fast installation and commissioning of the units described in this manual it is necessary to attentively read and observe the following notes and explanations.

1.1 Legal Basis

1.1.1 Copyright

This manual including all of its illustrations is copyrighted; deviations from the copyright stipulations are strictly prohibited. Reproduction, translation into foreign languages as well as electronic and photographic archiving or changes require the written approval of WAGO Kontakttechnik GmbH. Non observance will result in claims for damage.

WAGO Kontakttechnik GmbH reserves all rights for changes or amendments which serve technical progress. All rights for the issuing of patents or the protection of registered designs are reserved by WAGO Kontakttechnik GmbH. Products of other suppliers are always referred to without reference to patent rights. For this reason the existence of such rights cannot be excluded.

1.1.2 Personnel Qualification

The use of the product described in this manual is solely intended for qualified persons trained in PLC programming, qualified electricians or persons instructed by qualified electricians who are also familiar with the applicable standards and directives. WAGO Kontakttechnik declines all liability for faulty operation and damages to WAGO products and products from other suppliers resulting from non-observance of the information contained in this manual.

1.1.3 Intended Use

For the individual application, the components are supplied with a defined hardware and software configuration. Changes are only admitted within the framework of the possibilities documented in the manuals. All other changes to the hardware or software and any use of the components other than that intended entail the exclusion of liability on part of WAGO Kontakttechnik GmbH.

Please contact WAGO Kontakttechnik GmbH for any wishes in terms of a modified or a new hardware or software configuration.

1.2 Scope of Validity

This manual describes the fieldbus dependent I/O module of the WAGO-I/O-SYSTEM 752 for the CANopen.

Components	Article No.
Electronic Module	752-327
Base Module, D-SUB	752-827
Base Module, MCS	752-828

1.3 Symbols



Warning

Observe this information in all cases to protect the system from damage.



Attention

Marginal conditions to be observed in all cases to ensure a troublefree operation.



ESD (Electrostatic Discharge)

Warning of danger to the components by electrostatic discharge. Precautionary measure when handling components subject to electrostatic discharges.



Note

Routines or advice for an efficient use of the unit and for software optimisation.



Further information

Reference to additional literature, manuals, data sheets and INTERNET pages.

1.4 Abbreviations

Attr.	Attribute
CAL	CAN Application Layer
CAN	Controller Area Network
COB ID	Communication Object Identifier
COV	Change of Value
DI	Digital Input Digital Input Module
DO	Digital Output Digital Output Module
EDS	Electronic Data Sheets
EMCY	Emergency Objekt
I/O	Input/Output
ID	Identifier
Idx	Index
MCS	WAGO <i>MULTICONNECTOR</i> SYSTEM
NMT	Network Management
PDO	Process Data Object
RO	Read Only
RTR	Remote Transmit Request
RxPDO	Receive PDO
rw	Read/Write
SDO	Service Data Object
S-Idx	Sub-Index
TxPDO	Transmit PDO

2 System Description

The WAGO-I/O-SYSTEM 752 for CANopen is part of the compact series of WAGO field bus nodes for distributed automation. It has a fixed number of digital inputs (DI) and digital outputs (DO) and transmits the signals to a higher ranking control system via CANopen.

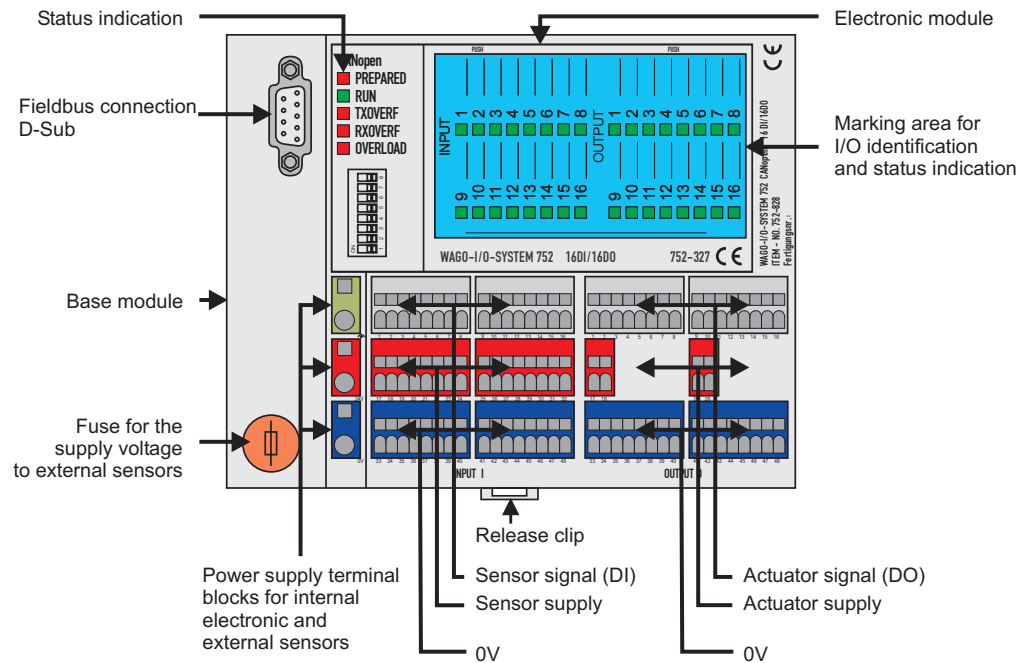

Fig. 2-1: I/O module for CANopen, D-SUB fieldbus connection

g1x2801e

The fieldbus dependent I/O module consists of

- the **base module** allows prewiring of the fieldbus, power supply, and sensor/actuator connections.
Two base modules with different fieldbus connectors are available:
 - 9 pole D-SUB fieldbus connector
 - 5-pole *MULTISTECKERSYSTEM* (Open Style) fieldbus connector
- the plug-in **electronic module** contains the processing unit, the fieldbus interface module, and the input and output circuits.

The electronic and base modules are supplied separately packed.

2.1 Base Module

The base module is the interface for all external wiring, including the fieldbus, power supply, and sensor/actuator connections. A multi-conductor connector links the external wiring to the plug-in electronic module.

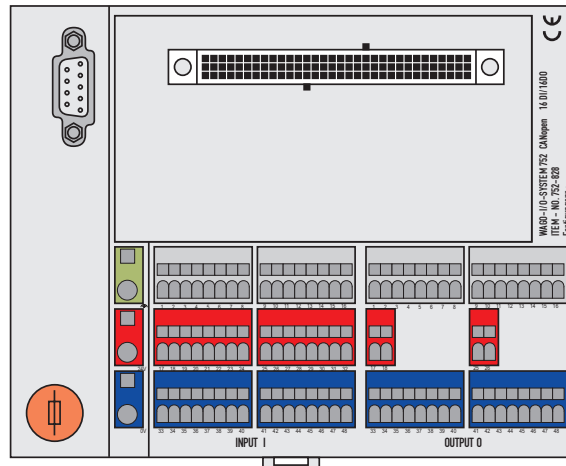

Fig. 2-2: Base Module 752-827

g1x2806x

- Fieldbus connection,
9 pole D-SUB for 752-827
5 pole MCS for 752-828
- Module power supply,
terminal block with CAGE CLAMP[®] 2.5 mm² connection
- Sensor connection,
3 conductors, terminal block with CAGE CLAMP[®] 1.5 mm² connection
- Actuator connection,
2 conductors, terminal block with CAGE CLAMP[®] 1.5 mm² connection
- Separate output supply voltage,
terminal block with CAGE CLAMP[®] 1.5 mm² connection
- Fuse holder with protective cap for input supply voltage fuse.
- Clear labeling of the connection group (INPUT or OUTPUT) and each individual terminal block (numbered)
- Wiring can be performed independent of the plug-in electronic module.

2.2 Electronic Module

The plug-in electronic module includes all electronic circuits, i. e. the power pack, the electrically isolated fieldbus interface module, the processing unit, the input and output circuits, and their corresponding status indicators.

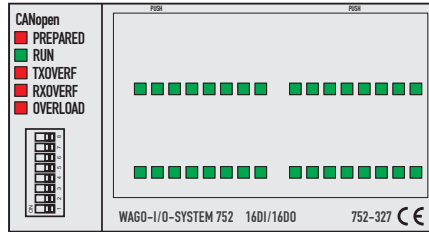

Fig. 2-3: Electronic Module

g1x2807x

- Plug-in design provides easily installation into the base module.

If a replacement of the electronic module is necessary, the wiring remains undisturbed.

- Status indicators for fast diagnostics.

The electronic module includes a marking area for I/O identification and status indication.

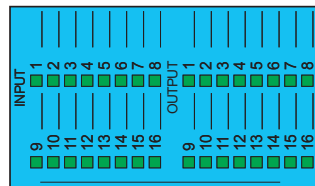

Fig. 2-4: Marking label

g1x2808x

Text can be added to the marking label using a permanent felt tip pen (order no. 210-110), or can be labeled by means of a plotter or a laser printer. The WAGO SCRIPT marking system has templates available for easy and professional customization of marking labels.

3 Technical Data

CANopen System data	
Transmission medium	Shielded Cu Cable
Max. length of fieldbus	40 m ... 1000 m (depends on baud rate /on the cable)
Baud rate	10 kBaud ... 1 MBaud
Buscoupler connection	1 x D-SUB 9 (752-828) 1 x MCS (752-827), Connector (231-305/010-000/050-000) is included

CANopen Device Data	
Number of PDO	2 Tx / 2 Rx
Number of SDO	1 Server SDO
Communication profil	DS-301
Device profil	DS-401
COB ID Distribution	SDO, Standard
Node ID Distribution	DIP Switch
Further CANopen Device Features	NMT Slave Minimum Boot-up Variables PDO Mapping Emergency Message Life Guarding

Supply	
Supply voltage	DC 24 V (– 15 % / + 20 %)
Current input (Module without load)	< 150 mA at 24 V DC
Total loss of power	< 4,5 W
Fuse F1 for sensor supply	TR5 250 V / 6,3A T Note: Use UL-Recognized fuse only

General information	
Dimensions W x H x L	(155 x 129 x 60 [*]) mm
Housing material	Polycarbonat
Fixing	Snap mounting onto 35 DIN carrier rail EN 50022-35
Fitting position	vertical and horizontal
Weight	approx. 500 g

* from upper edge of DIN 35 rail

Wire connection	
Power supply	CAGE CLAMP® 0.08 mm² ... 2.5 mm², AWG 28-12*
Sensors, actuators	CAGE CLAMP® 0.08 mm² ... 1.5 mm², AWG 28-16
Supply voltage for outputs (8 circuit group)	CAGE CLAMP® 0.08 mm² ... 1.5 mm², AWG 28-16

* AWG12: THHN, TWHN

Inputs	
Number of inputs	16
Input	in accordance with EN 61131-2, type 1
Wire connection	for 3 conductors
Signal voltage (0)	DC -3 V ... +5 V
Signal voltage (1)	DC 15 V ... 30 V
Time constant	5 ms
Insulation electronics/field side	none

Outputs	
Number of outputs	16
Rated voltage	DC 24 V
Rated current – max. per output – max. per group (8 outputs) – max. per module 16 DO	500 mA 4 A 8 A
Leakage current	< 2 mA
Short circuit protection	electronic, automatic restart
Max. operating frequency (without bus) – resistive load – inductive load	1 kHz utilization category DC 13, equals 6 Hz
Insulation electronics/field side	none
Diagnosis	Short circuit display by LED (OVERLOAD) for the entire module; signalling via bus for 4 outputs each
Feeding	<ul style="list-style-type: none"> all through supply terminal blocks 24 V, 0 V, \varnothing in groups via supply terminal blocks for 8 outputs each

Degree of Protection	
Degree of protection according to EN 60 529	IP 20 protection against physical contact with standard test probes

Conformity and Certification	
Conformity labelling	CE
UL	E175199, UL 508

Climatic Environmental Conditions	
Operating temperature	0 °C ... 55 °C
Storage temperature	-25 °C ... +70 °C
Relative air humidity	10 ... 45 % , no dew formation
Air pressure in operation	86 ... 106 hPa
Maximum altitude	max. 2000 m above sea level
Strain by harmful substances	Inspection according to IEC 60068-2-42 and IEC 60068-2-43
Special conditions	Exercise caution when subjecting the I/O modules to the following conditions: – dust, corrosive vapors or gasses – ionized radiation.

Mechanical Strength	
Vibration	According to IEC 60068-2-6, inspection Fc 10 ... 57 Hz constant amplitude 0.075 mm 57 ... 150 Hz constant acceleration 1 g
Impact	According to IEC 60068- 2-27; 15 g, 11 ms

Electrical Safety	
Reverse voltage protection	Yes
Air and creepage distances	According to DIN EN 61131-2 and DIN EN 50178 between current circuits and body as well as between electrically isolated, separate current circuits, according to over-voltage category II, degree of pollution 2
Isolation	Yes, between fieldbus and internal electronics
Test voltage	DC 500 V

Electromagnetic Compatibility			
Interference Resistance according to EN50082-2 : 1995			
EN 61000-4-2	4kV/8kV	(2/4)	B
EN 61000-4-3	10V/m 80% AM	(3)	A
EN 61000-4-4	2kV	(3/4)	B
EN 61000-4-6	10V/m 80% AM	(3)	A
Interference emission according to EN50081-2 : 1994			
EN 55011	30 dB μ V/m	(30 m)	
	37 dB μ V/m		

Dimensions / Distances

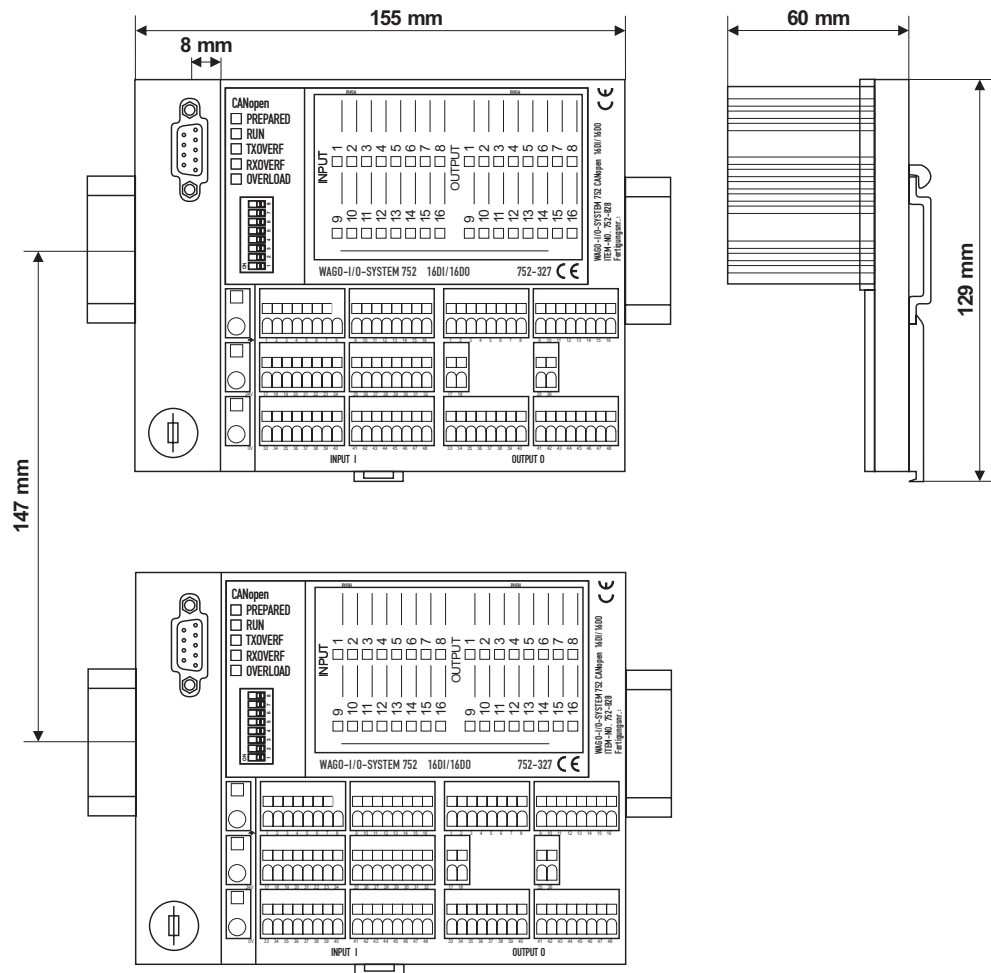

Fig. 3-1: Dimensions

g1x2810x

Distances to building walls	
RH / LH:	0 mm
Top:	20 mm
Bottom:	20 mm
Front:	0 mm when fitted 150 mm fitting space



Attention

The distances between I/O module(s) and building walls have to be observed in order to guarantee sufficient ventilation.

4 Installation

4.1 Mechanical Installation

4.1.1 Snapping on / Detaching the Base Module

The WAGO-I/O-SYSTEM 752 is intended for mounting on a TS35 type carrier rail. The base module snaps onto the carrier rail.

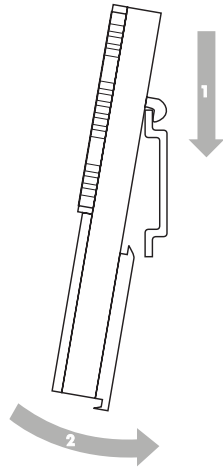

Fig. 4-1: Snapping the Base Module onto the carrier rail

g1xx08x

The module can be detached from the carrier rail by releasing the latch using a suitable tool (screw driver).

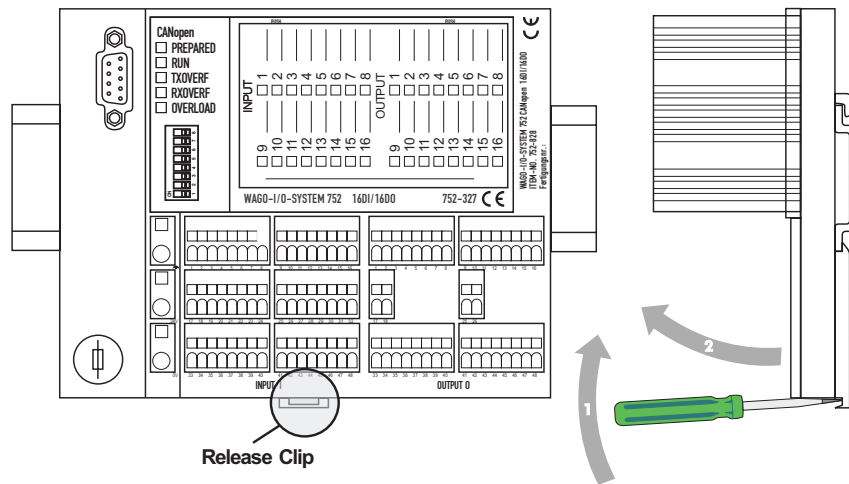

Fig. 4-2: Detachment of the I/O module from the carrier rail

g1x2811e

4.1.2 Insertion/Extraction of the Electronic Module

The electronic module is plugged onto the base module.



Attention

Remove power from the base module before installing the electronic module.

Apply force at the positions marked "PUSH" when plugging in the electronic module.

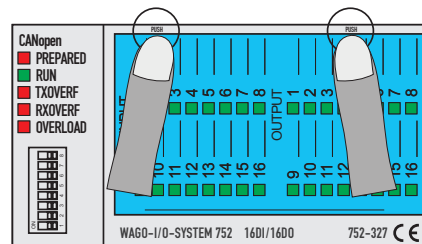

Fig. 4-3: Plugging in the Electronic Module

g1x2802x

The electronic module is correctly inserted when all four latches have engaged.

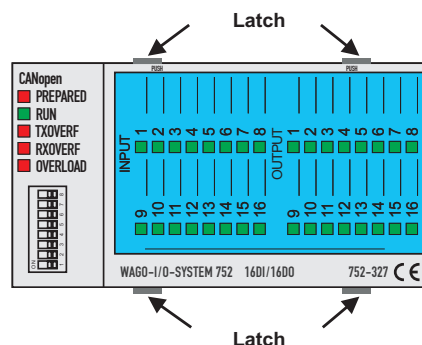

Fig. 4-4: Extracting the Electronic Module

g1x2803e

The electronic module can be extracted by pressing the 4 latches and simultaneously pulling it from the base module.

4.1.3 Marking Label

The plastic marking label can be removed from the mounting points by applying slight finger force. To accomplish this, slide the label from one side such that the label bends.

Insert the label by proceeding in the reverse order.

4.1.4 DIP Switch

4.1.4.1 Ansicht

The DIP switch on the module is intended not only for configuration purposes but also for the local setting of the ID, that is internally used for computing the COB IDs of PDO1/2, SDO and Emergency Object in accordance with DS301-"Predefined Connection Set".

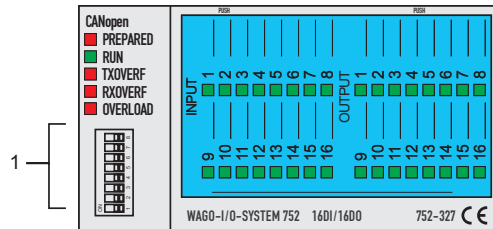

Fig. 4-5: DIP Switch

g1x2804x

4.1.4.2 Module ID

The binary valency of the module ID set on the DIP switch increases towards the switch number, whereby a logic '1' is represented by an 'ON'.

Module ID	DIP8	DIP7	DIP6	DIP5	DIP4	DIP3	DIP2	DIP1
0 (Configuration Mode)	OFF	OFF	OFF	OFF	OFF	OFF	OFF	OFF
1 ^{*)}	OFF	OFF	OFF	OFF	OFF	OFF	OFF	ON
2	OFF	OFF	OFF	OFF	OFF	OFF	ON	OFF
:								
255	ON	ON	ON	ON	ON	ON	ON	ON

^{*)} Default

4.1.4.3 Baud rate / Configuration Mode

The baud rate is set in the configuration mode and is entered as a default value via the DIP switches 1 to 4. The module saves the setting if DIP switch 8 is switched over from 'OFF' to 'ON'.

Baud rate	DIP1	DIP2	DIP3	DIP4	DIP5	DIP6	DIP7	DIP8
1 MBd	OFF	OFF	OFF	OFF	Not used	Not used	Not used	Accepting the configuration settings
800 kBd	ON	OFF	OFF	OFF				
500 kBd	OFF	ON	OFF	OFF				
250 kBd	ON	ON	OFF	OFF				
125 kBd ^{*)}	OFF	OFF	ON	OFF				
100 kBd	ON	OFF	ON	OFF				
50 kBd	OFF	ON	ON	OFF				
20 kBd	ON	ON	ON	OFF				
10 kBd	OFF	OFF	OFF	ON				

^{*)} Default

If all DIP switches are set to OFF when switching on the module, the module starts in the configuration mode. In this status, the currently set baud rate is displayed via LEDs.

LED	Related DIP switch or Baud rate identifier
RUN	DIP4
TXOVERF	DIP3
RXOVERF	DIP2
Overload	DIP1

Slow flashing of the relevant LEDs indicates the currently set baud rate. Once saved, the new baud rate is shown by the relevant LEDs having steady light.

The baud rate 1 MBaud is indicated by the module by flashing or lighting up of all 4 LEDs.

Example: 125 kB = TXOVERF LED flashes



Attention

To set the module ID on the DIP switch, switch off the operating voltage beforehand, knowing that the set value is only used as a module ID to compute the IDs with Power-On.

During coding using a DIP switch, no data exchange with the module is possible.

4.2 Electrical Installation

4.2.1 General



ESD (Electrostatic Discharge)

The components are equipped with electronic components susceptible to be destroyed when exposed to electrostatic load. Therefore, when handling these components, ensure proper grounding of the surrounding objects and persons (workplace, packing). Avoid contact with electrically conductive components, e. g. the pins of a plug.

All connecting terminal blocks for the supply voltages and sensor and actuator connections are equipped with CAGE CLAMP® connectors.

These CAGE CLAMP® connectors are suitable for fine-stranded and solid conductors. When using ferrules, select the next smaller nominal cross section for the conductor.

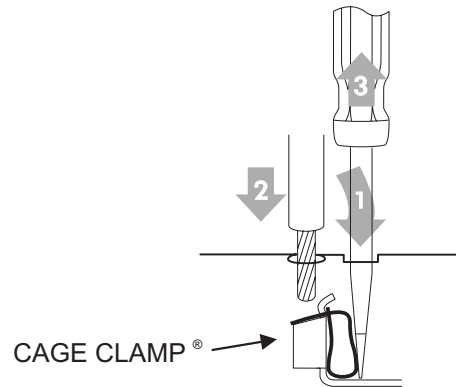

Fig. 4-6: How to operate the CAGE CLAMP®

g1xxx10x

The WAGO-I/O-SYSTEM 752 requires a 24 V DC supply.

The sensors supply voltage is short circuit protected by means of the plug-in fuse F1 (TR 5 / 250 V / 6.3A T).



Note

Use UL-Recognized fuse only

The supply voltage for the outputs can be fed through the module, or sourced separately. Rate the electrical fusing according to the technical data.

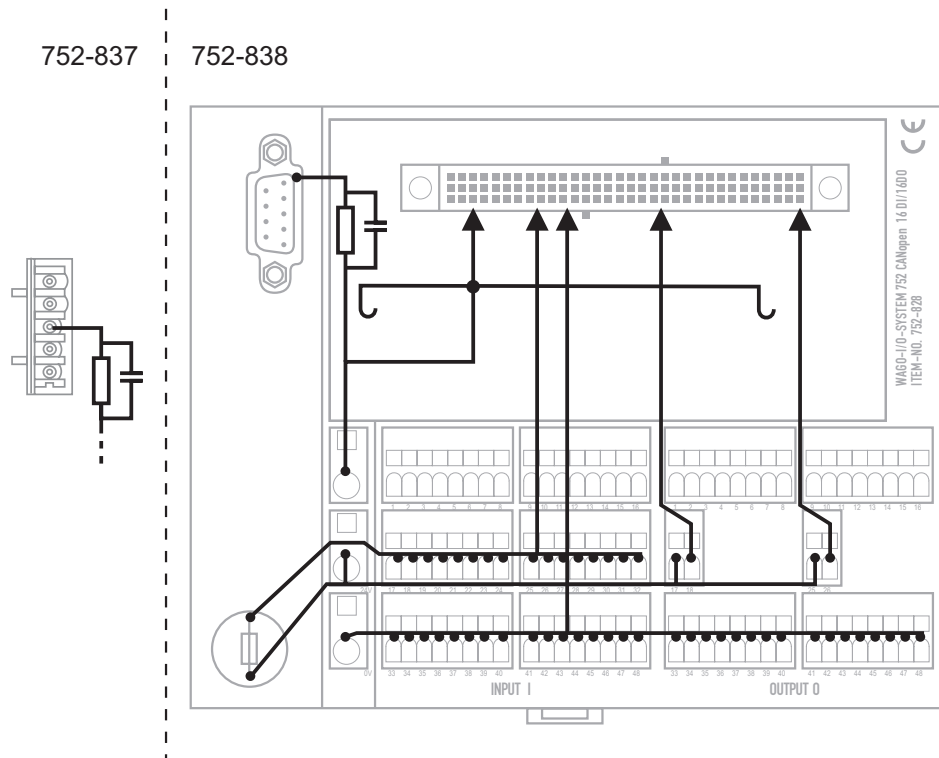

Fig. 4-7: Power supply

g1x2800x

Two carrier rail contacts are provided on the underside of the base module to ensure electrical contact between the grounded carrier rail and the I/O module. The contacts are directly connected to the ⚡ terminal block.



Attention

Ensure that solid contact is made between the carrier rail contacts on the underside of the base module and the carrier rail itself.
The carrier rail must be grounded.

4.2.2 Connection of the Module Supply Voltage

The connection of the module supply voltage and earth ground is made on terminal blocks carrying the following labeling:

- 24 V (red terminal block)
- 0 V (blue terminal block)
- ⚡ (green terminal block)

Connection of earth ground to the base module's ground terminal is required for reliable module operation.

4.2.3 Connection of the Input Signals

The input signal connection group is identified by the imprint "INPUT" on the base module. Three terminals are available for each digital input. The terminals for one input are shown superimposed.

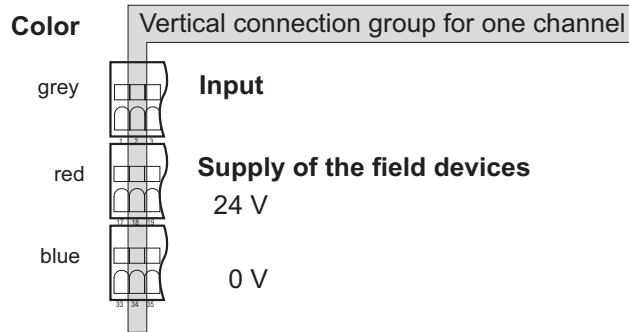

Fig. 4-8: Connection of the Input Signals

g1xxx03e

2-conductor sensors, e. g. switches, are connected to the grey and red terminal blocks.

3-conductor sensors receive their 24 VDC supply voltage through the connection to the red and the blue terminal blocks. The output signal of the 3-conductor sensor is connected to the grey terminal block.

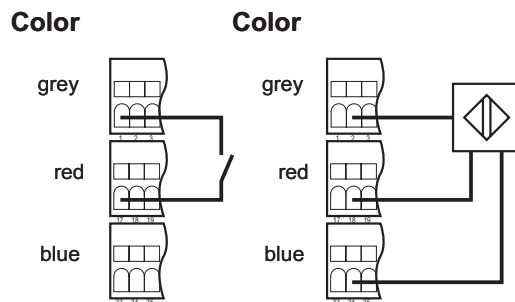

Fig. 4-9: Examples of a sensor connection

g1xxx04e

4.2.4 Connection of the Output Supply Voltage

The supply voltage for the two output groups of 8 connections each can be provided either internally using the supply voltage for the module, or externally from a separate power source. The base modules are provided with two sets of terminal blocks in the middle row of the output terminals. The left-hand terminal of each set carries the 24VDC module power, while the right-hand terminal provides a connection point for the output supply voltage.

The base modules are shipped with jumpers installed in each of these terminals, connecting 24VDC module power to connection point for the output supply voltage.

Color

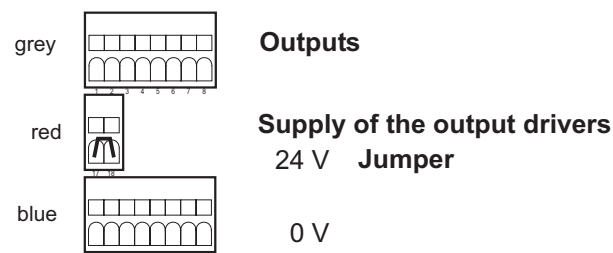

Fig. 4-10: Output supply voltage, internal

g1xx05e

The factory-installed jumper has to be removed when a separate power supply for a group of 8 digital outputs is required. The separately fused or switchable power supply is connected to the right-hand connection point.

Color

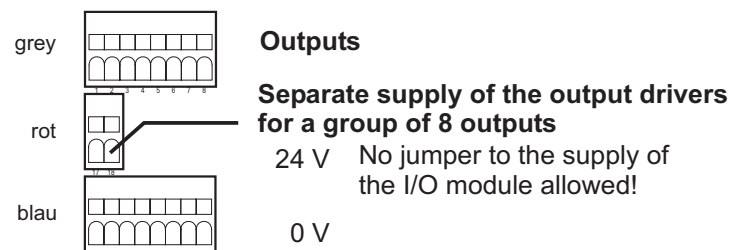

Fig. 4-11: Output supply voltage, separate

g1xx06e



Attention

When providing a separate output supply voltage to a group of 8 outputs, the supply voltage common must be terminated on the base module using the 0 V potential of the WAGO-I/O-SYSTEM 752 (blue terminal block).

The entire current load is applied to the common terminal connection. If more than 6 Amps is applied to the common terminals, separate terminal blocks should be used. Connect all common connections to the terminal blocks, and then connect the 752 common to the terminal blocks. This row of terminal blocks will be wired back to the source common of the supply potential.

4.2.5 Connection of the Output Signals

The output signal terminals are identified by the imprint "OUTPUT" on the base module.

Two terminals are available for each digital output. The terminals for one output are shown superimposed.

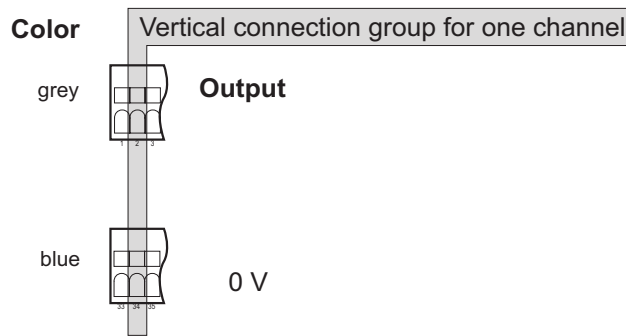

Fig. 4-12: Actuator connection

g1xxx07e

The positive connection of an actuator is wired to the grey output terminal block. The negative connection of an actuator is wired to the blue output terminal block.

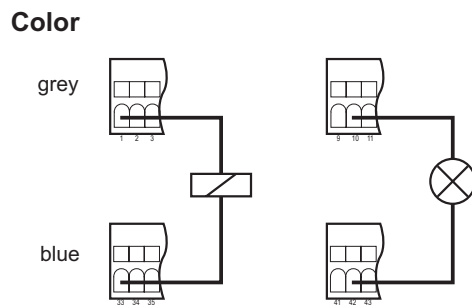

Fig. 4-13: Examples of an actuator connection

g1xxx09e

4.2.6 Connection of the Fieldbus Interface

The WAGO-I/O-SYSTEM 752 for CANopen provides two base modules.

4.2.6.1 Fieldbus Connection 9 pole D-SUB female connector

The fieldbus connection with the 9-pole connector is on the base module with the item number 752-828.

9 pole D-Sub female connector

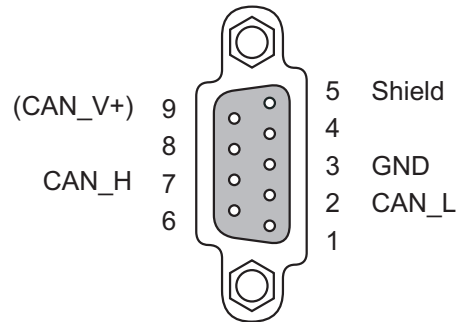

Fig. 4-14: Connection design D-SUB

g1xx800e

4.2.6.2 Fieldbus Connection 5 pole male connector

The fieldbus connection with the 5-pole connector is on the base module with the item number 752-827.

5-pol. male connector

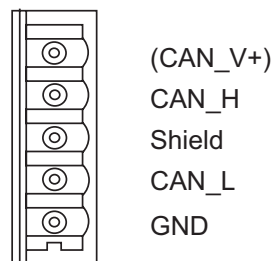

Fig. 4-15: Connection design *MULTISTECKERSYSTEM*

g1xx700e

The Open-Style Connector 231-305/010-000/050-000 from the WAGO *MULTI CONNECTION SYSTEM* is included. The Connector has gold plated contacts and printed signal marking at the contact location.

For the connection of smaller cross-sections an insulation stop of series 231-670 (white 0.08 - 0.2mm), 231-671 (light gray 0.25 - 0.5mm) or 231-672 (dark gray 0.75 - 1mm) should be used. The marking of the connectors can be made with 210-312. Additionally, housing parts, test plugs with cable and male connectors for cable extensions are available from the MCS series (pin spacing 5.08 mm / 0.200 in). Please contact your local WAGO office or distributor for further information on the MCS series.

4.2.7 Cabling of the Fieldbus

4.2.7.1 Shielding

To achieve a high system resistance to interfering electro-magnetic radiation, always use a screened data line.

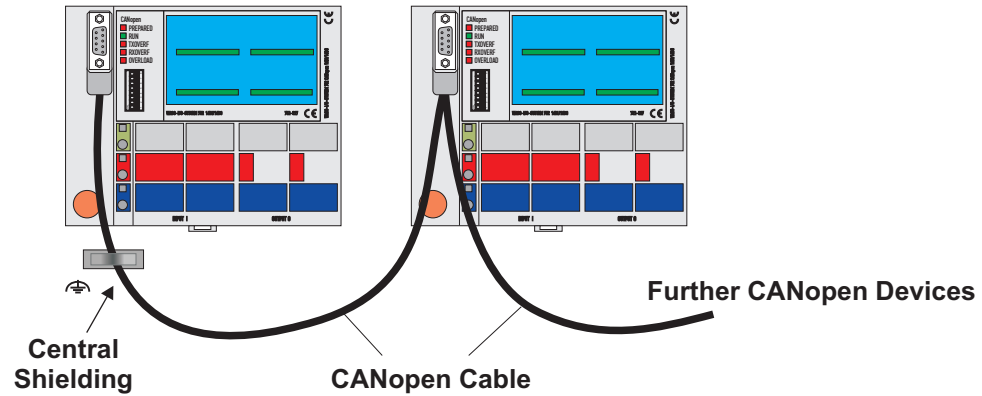

Fig. 4-16: Part of a CANOpen fieldbus cabling

g1xx801e



Attention

Only install one central grounding point for the entire CAN bus line. If possible, establish the connection directly at the bus line using low impedance screening systems.

The data line should be routed separately from all high current carrying cables.



Note

WAGO offers the screen connection system, series 790, for an optimum connection between the fieldbus cable screen and the function earth.

As an option, the cable screen can be routed to the 'Shield' plug pin. By means of an RC combination, the contact is connected to the function earth and as such with the carrier rail.

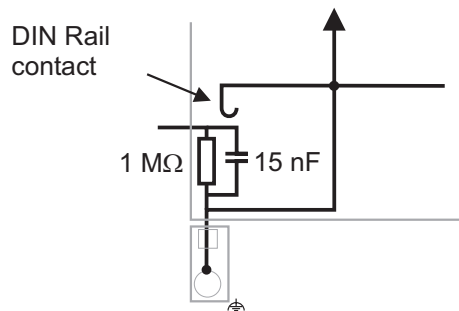

Fig. 4-17: Shield connection

g112400e

4.2.7.2 Termination Resistors

**Attention**

The bus cable must be terminated with a resistor ($121 \Omega / \pm 1\% / \frac{1}{4} \text{ W}$). The resistor is contacted with CAN_H and CAN_L.

Should problems occur during commissioning, your first step should be to measure the resistance between CAN_L and CAN_H.

- If the result is approx. 60Ω , both termination resistors are present.
- If the measuring result is considerably below 60Ω , more than 2 termination resistors are present.
- If the measuring result considerably exceeds 60Ω , only one or no termination resistor is present.

4.2.7.3 Bus Voltage Level

The bus voltage level are measured at a recessive state between

- CAN_L and CAN_H : approx. 0 V
- GND and CAN_L : approx. 2,5 V
- GND and CAN_H : approx. 2,5 V

The bus voltage level are measured at a dominant state between

- CAN_L and CAN_H : approx. 1 V
- GND and CAN_L : approx. 1,5 V
- GND and CAN_H : approx. 3,5 V

5 Schematic Circuit Diagram

A basic representation of the input, output and supply circuitry are shown in the schematic circuit diagram.

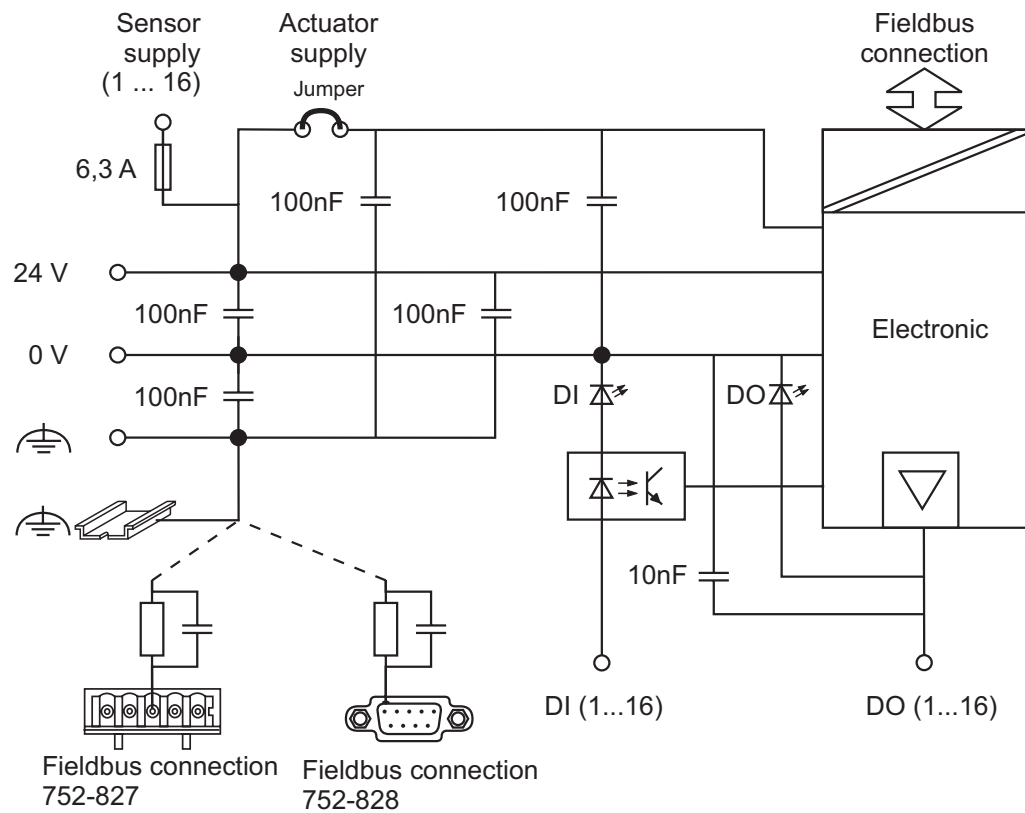

Fig. 5-1: Schematic Circuit Diagram

g1x2809e

6 Status Indicators

The electronic module incorporates LED's for displaying the status of the fieldbus connection, the status of the inputs and outputs, and interference in the output circuit.

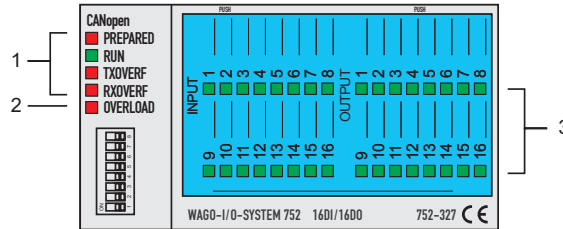

Fig. 6-1: Status Indicators

g1x2805x

- 1 Fieldbus (CANopen) specific status indicators.
- 2 Interference in the output circuit is displayed as a collective fault marked "OVERLOAD".
- 3 Status LED's for the inputs and outputs are integrated in the area of the marking label.

6.1 Input Status Indicators

The LED's are connected in series with the base module sensor connections, and will illuminate when a threshold input voltage is present.

Input voltage	Input value	LED
-3 V ... +5 V	'0'	OFF
+5 V ... +15 V	Not defined	Not defined
+15 V ... +30 V	'1'	ON

6.2 Output Status Indicators

The output status LED's display the actual state of each output. They will not be illuminated in the event of a short circuit at the output or a missing supply voltage to the output drivers.

Output value of the higher ranking controls	Fault	LED
'1'	None	ON
'0'	None	OFF
'1'	Short circuit	OFF
'0'	Short circuit	OFF
'1'	No supply	OFF
'0'	No supply	OFF

'1' = Output switched on

'0' = Output switched off

6.3 Fieldbus Interface Status Indicators

The operating states of the communication via CAN are indicated with the fieldbus specific LED's.

PREPARED	RUN	TXOVERF	RXOVERF	Meaning	Remedy
OFF	OFF	OFF	OFF	None function or self-test	check supply (24V and 0V), wait for self-test
OFF	SLOW FLASHING	X	X	Module is in the state PRE-OPERATIONAL	
ON	OFF	X	X	Module is in the state PREPARED	
OFF	ON	X	X	Module is in the state OPERATIONAL	
X	X	X	ON	CAN receiver buffer is full. Data loss is likely.	Increase the time span between 2 protocols.
X	X	ON	X	CAN transmitter buffer is full. Data loss is likely.	Check the data sizes of the bus system. Increase the transmit priority of the module.
X	X	FAST FLASHING in turns with RXOVERF	FAST FLASHING in turns with TXOVERF	CAN Controller exceeded the Warning Level, to much error telegrams	Check baud rate and bus connection, install min. 2 modules in the network.
X	X	FAST FLASHING	FAST FLASHING	CAN Controller was in the state BusOff. Is reseted and re-started.	Check wiring and connection of the nodes and evaluate EMC interference.
OFF	FAST FLASHING	X	X	Module is in the state PRE-OPERATIONAL, Sync/Guard Message failed	Change into the state OPERATIONAL and restart Sync/Guard message
FAST FLASHING	OFF	X	X	Module is in the state PREPARED, Sync/Guard message failed	Change into the state OPERATIONAL and restart Sync/Guard message

6.4 Overload Status Indicator

The LED designated "OVERLOAD", when illuminated, indicates the presence of an output fault.

Possible output faults:

- Short circuit of one or more outputs
- Missing supply voltage to the output drivers
- Fault of an output driver
- Feedback
- Communication error

A fault is detected if a transmitted value of '1' by the master controller does not produce a threshold voltage at a corresponding output.

The I/O module switches the LED off again once the fault has been corrected. The I/O module switches the LED off after a 1 second delay and and reset the bit in the attribute Module Status Value.

7 CANopen

7.1 Review

CAN (Controller Area Network) was developed in the mid 1980s for data transmission in motor vehicles. The CAN specifications define the data link layer. This is the physical and data security layer, i.e. basically the means are described via which data transmission takes place. It does not say anything about the application layer.

CANopen instead describes the application layer or the meaning of the transmitted data. It is therefore a general description language for CAN networks and offers a wide range of communication services.

CANopen is a type of network which is based on the serial bus system CAN and the application layer CANopen. Unlike CANopen, CANopen determines what data and what services are to be transmitted and what is the meaning of the data for the individual device classes. That's why only part of the communication services offered by CANopen are used. This has the advantage that lower computer performance and storage capacities are needed.

CANopen is therefore a standard application layer defined by the CAN specifications DS 301.

The so-called network management allows a simplified net initialization. This net can be extended by any component the user likes.

CAN is a multimaster bus system. In contrast to other fieldbus systems, the modules connected to the bus are not identified but the messages are. The partners are allowed to send messages at any time the bus is free. Bus conflicts are solved in such a way that the messages are sent at a certain priority level. CAN always sends broadcast messages which are divided into 2032 priority levels. All partners have the same rights so that communication is also possible without a busmaster.

Each partner decides on its own when it wants to send its data. It is, however, also possible to make other partners send their data. This demand is made via the so-called remote frame.

The CANopen specifications (DS 301) determine the technical and functional features with which the individual devices for field automation can be networked/put together to a network. CANopen distinguishes between Client and Server devices.

7.2 Module properties

The I/O Module from the WAGO-I/O-SYSTEM 752 for CANopen is sorted to server devices. The module supports the following functions:

- CANopen Minimum Capability Device
- Node Guarding
- 2 Transmit (Tx-) PDO
- 2 Receive (Rx-) PDO
- 1 Standard SDO
- 1 Emergency Object
- 1 Synchronisation object (without Timestamp)
- Implementation of the error register (Index 0x1003)

After Power On, the module loads the standard settings and then changes to the PRE-OPERATIONAL status. The communication as well as the mapping parameters of the PDOs can be changed and saved (Index 0x1010).



Attention

If upon saving a configuration only the module ID is changed by means of the DIP switch, the saved configuration is continued to be used. This means that all module ID specific entries in the object directory (objects being dependent on the module ID and having the "rw" attribute) signal with the old values (e.g. Emergency ID, Node Guarding ID, ...).

In the CANopen profile DS-401 the module maps the following objects:

- Maximum 4 digital input blocks (Index 0x6000)
- Maximum 4 digital output blocks (Index 0x6200)

The non-profile specific I/O functionality is mapped into the 'Manufacturer Specific Area'. Here we again deal with the I/O data (index 0x2000 and 0x2100) as well as with the diagnosis information of the outputs (index 0x5900). In the communication profile area the objects 0x1000 - 0x1200 are supported as described in chapter Communication Profile Area. The objects for the PDO configuration: index 0x1400 and 0x1401, 0x1600 and 0x1601, 0x1800 and 0x1801 and 0x1A00 and 0x1A01 can also be used.

7.3 Object Directory

The Object directory is divided in three areas:

- Communication Profile Area (Index 0x1000 - 0x1BFF)
- Manufacturer Specific Profile Area (Index 0x2000 - 0x5FFF)
- Standard Device Profile Area für DS-401 (from Index 0x6000)

7.3.1 Communication Profile Area

Idx	S-Idx	Name	Type	Attr.	Default* / Presetting	Meaning
0x1000	0	Device Type	Unsigned32	ro	401, 03	Device Type Low byte: Dev.Profile Nb. = 401 High byte: Digital in/outputs = 03
0x1001	0	Error Register	Unsigned8	ro	None / 0	Errors are bit coded (DS401)
0x1003	0	Pre-defined Error Field	Unsigned8	rw	None / 0	Number of different errors that occurred, writing a 0 deletes the error list
	1	letzter aufgetretener Fehler	Unsigned32	ro	None / 0	Description of the error
	:					
	5		Unsigned32	ro	None / 0	Max. 5 errors are supported
0x1004	0	Number of PDOs supported	Unsigned32	ro	None / 0x00020002	Number of supported synchronous und asynchronous RX and TX PDOs
	1	Number of synchronous PDOs	Unsigned32	ro	None / 0x00020002	Number of supported synchronous RX and TX PDOs
	2	Number of asynchronous PDOs	Unsigned32	ro	None / 0x00020002	Number of supported asynchronous RX and TX PDOs
0x1005	0	COB-ID SYNC message	Unsigned32	rw	0x80000080	COB-ID of the SYNC object, device consumes the SYNC message
0x1006	0	Communication Cycle Period	Unsigned32	rw	0x00000000	defines teh communication cycle period (LSB = 1µs)
0x1008	0	Manufacturer Device Name	Visible String	ro	752-327	Device name of the module
0x1009	0	Manufacturer Hardware Version	Visible String	ro	Current version	Hardware Version of the module
0x100A	0	Manufacturer Software Version	Visible String	ro	Current version	Software Version of the module
0x100B	0	Node ID	Unsigned32	ro	Node no.	Configured node id
0x100C	0	Guard Time	Unsigned16	rw	0x0000	Guard Time in milliseconds
0x100D	0	Life Time Factor	Unsigned8	rw	0x00	Multiplicator with the Guard Time, Result is the max. delay between two guarding selegrams
0x100E	0	Node Guarding Identifier	Unsigned32	rw	0x00000700 + Node-ID	ID for node guarding and life guarding procedur
0x100F	0	Number of SDOs Supported	Unsigned32	ro	None / 1 0x00000001	Number of supported SDOs 0 client SDOs, 1 server SDOs
0x1010	0	Store Parameters	Unsigned8	ro	0x01	max. number of store parameters
	1	save all parameters	Unsigned32	rw	0x00000001	Device stores on command. The signature 'save' (MSB 0x65 76 61 73 LSB) must be written on this index

Idx	S-Idx	Name	Type	Attr.	Default* / Presetting	Meaning
0x1011	0	Restore default parameters	Unsigned8	ro	0x04	Number of restore options
	1	restore all default parameters	Unsigned32	rw	0x00000001	By writing the signature "load" (MSB 0x64 61 6F 6C LSB) the default parameter are loaded. They work after power on.
	2	restore communication default parameters	Unsigned32	rw	0x00000000	Not implemented
	3	restore application default parameters	Unsigned32	rw	0x00000000	Not implemented
	4	restore all default parameters and use them until next save command	Unsigned32	rw	0x00000001	By writing the signature "load" (MSB 0x64 61 6F 6C LSB) the default parameter are loaded. They work until the next SAVE command.
0x1014	0	COB-ID Emergency Message	Unsigned32	rw	0x40000080 + Node-ID	COB ID of Emergency message
0x1200	0	Server SDO Parameter	Unsigned8	ro	None / 0x02	Number of valid Sub-Indices
	1	Receive SDO COB-ID	Unsigned32	ro	0x00000600 + Node ID	COB-ID of receive SDO
	2	Transmit SDO COB-ID	Unsigned32	ro	0x00000580 + Node ID	COB-ID of transmit SDO
0x1400	0	Receive PDO Communication Parameter	Unsigned8	ro	0x02	Communication parameter 1. Rx-PDO Number of valid Sub-Indices
	1	COB-ID	Unsigned32	rw	0x00000200 + Node-ID	COB-ID of 1. Rx PDO
	2	Transmission Type	Unsigned8	rw	0xFF	transmission type defined in DSP401
0x1401	0	Receive PDO Communication Parameter	Unsigned8	ro	0x02	Communication parameter 2. Rx-PDO Number of valid Sub-Indices
	1	COB-ID	Unsigned32	rw	0x00000300 +Node-ID	COB-ID of 2. Rx PDO
	2	Transmission Type	Unsigned8	rw	0xFF	transmission type defined in DSP401
0x1600	0	Receive PDO Mapping	Unsigned8	rw	Device Profil depended	Mapping parameter of 1. Rx PDO Number of valid Sub-Indices
	1	1.Objekt	Unsigned32	rw	Device Profil depended	
	:	:	:	:	:	
	8	8.Objekt	Unsigned32	rw	Device Profil depended	
0x1601	0	Receive PDO Mapping	Unsigned8	rw	Device Profil depended	Mapping parameter of 2. Rx PDO Number of valid Sub-Indices
	1	1.Objekt	Unsigned32	rw	Device Profil depended	
	:	:	:	:	:	
	8	8.Objekt	Unsigned32	rw	Device Profil depended	
0x1800	0	Transmit PDO Communication Parameter	Unsigned8	ro	0x03	Communication parameter 1. Tx-PDO Number of valid Sub-Indices
	1	COB-ID	Unsigned32	rw	0x00000180 +Node-ID	COB-ID of 1. Tx PDO
	2	Transmission Type	Unsigned8	rw	0xFF	transmission type defined in DSP401 on 255
	3	Inhibit Time	Unsigned16	rw	0x0000	min. delay before the next PDO will be send (LSB = 100µs)

Idx	S-Idx	Name	Type	Attr.	Default* / Presetting	Meaning
0x1801	0	Transmit PDO Communication Parameter	Unsigned8	ro	2-4 / 0x03	Communication parameter 2. Tx-PDO Number of valid Sub-Indices
	1	COB-ID	Unsigned32	rw	0x00000280 + Node-ID	COB-ID of 2. Tx PDO
	2	Transmission Type	Unsigned8	rw	0xFF	transmission type defined in DSP401 on 255
	3	Inhibit Time	Unsigned16	rw	None / 0x0064	min. delay before the next PDO will be send (LSB = 100µs)
0x1A00	0	Transmit PDO Mapping	Unsigned8	rw	Device Profil depend- ing	Mapping parameter of 1. Tx PDO Number of valid Sub-Indices
	1	1.Objekt	Unsigned32	rw	Device Profil depend- ing	
	:	:	:	:	:	
	8	8.Objekt	Unsigned32	rw	Device Profil depend- ing	
0x1A01	0	Transmit PDO Mapping	Unsigned8	rw	Device Profil depend- ing	Mapping parameter of 2. Tx PDO Number of valid Sub-Indices
	1	1.Objekt	Unsigned32	rw	Device Profil depend- ing	
	:	:	:	:	:	
	8	8.Objekt	Unsigned32	rw	Device Profil depend- ing	

*) according to DS301 / Version 3.0 Specification

7.3.2 Manufacturer Specific Device Profile

7.3.2.1 Digital Inputs

Idx	S-Idx	Name	Type	Attr.	Default Value	Meaning
0x2000	0	8-Bit digital input block	Unsigned8	ro	0x02	Number of digital 8 bit input blocks
	1	1. input block	Unsigned8	ro	None	1. digital input block
	2	2. input block	Unsigned8	ro	None	2. digital input block

7.3.2.2 Digital Outputs

Idx	S-Idx	Name	Type	Attr.	Default Value	Meaning
2100	0	8-Bit digital output block	Unsigned8	ro	0x02	Number of digital 8 bit output blocks
	1	1. output block	Unsigned8	rw	None	1. digital output block, 1...8
	2	2. output block	Unsigned8	rw	None	2. digital output block, 9...16

7.3.2.3 Diagnosis of the outputs

Idx	S-Idx	Name	Type	Attr.	Default Value	Meaning
5900	0	diagnosis of the outputs	Unsigned8	ro	0x02	Number of diagnosis byte
	1	1. diagnosis byte	Unsigned8	ro	0x00	Diagnosis byte outputs 1...8
	2	2. diagnosis byte	Unsigned8	ro	0x00	Diagnosis byte outputs 9...16

7.3.3 Standard Device Profile

7.3.3.1 8-Bit digital input block, 0x6000

Idx	S-Idx	Name	Type	Attr.	Default Value	Meaning
0x6000	0	Number Blocks 8 Inputs State	Unsigned8	ro	None	Number of digital input blocks
	1	Read 8 Inputs 1 ... 8	Unsigned8	ro	None	1. digital input block, inputs 1... 8
	2	Read 8 Inputs 9 ... 16	Unsigned8	ro	None	2. digital input block, inputs 9 ... 16

7.3.3.2 8-Bit digital output block, 0x6200

Idx	S-Idx	Name	Type	Attr.	Default Value	Meaning
0x6200	0	Number Blocks 8 Outputs State	Unsigned8	ro	None	Number of digital output blocks
	1	1. Write 8 Outputs 1 ... 8	Unsigned8	rw	None	digital output block, outputs 1 ... 8
	2	2. Write 8 Outputs 9 ... 16	Unsigned8	rw	None	digital output block, outputs 9 ... 16

7.3.3.3 Error Mode of digital 8-Bit output blocks, 0x6206

Idx	S-Idx	Name	Type	Attr.	Default Value	Meaning
0x6206	0	Number of Output 8-Bit	Unsigned8	ro	2	Number of digital output blocks
	1	1. Error Mode Outputs 1 ... 8	Unsigned8	rw	0xFF	1. Bit Mask for the digital outputs 1 ... 8
	2	2. Error Mode Outputs 9 ... 16	Unsigned8	rw	0xFF	2. Bit Mask for the digital outputs 9 ... 16

7.3.3.4 Error output value of digital 8-Bit output blocks, 0x6207

Idx	S-Idx	Name	Type	Attr.	Default Value	Meaning
0x6207	0	Number of Output 8-Bit	Unsigned8	ro	2	Number of digital output blocks
	1	1. Error Value Outputs 1 ... 8	Unsigned8	rw	0	1. output value in case of error for digital outputs 1 ... 8
	2	2. Error Value Outputs 9 ... 16	Unsigned8	rw	0	2. output value in case of error for digital outputs 9 ... 16

7.3.3.5 State switching in case of error, 0x67FE

Idx	S-Idx	Name	Type	Attr.	Default Value	Meaning
0x67FE	0	Number of Error Classes	Unsigned8	ro	2	Number of supported Sub-Indices
	1	Communication Error	Unsigned8	rw	0	State definition after communication error
	2	Output Error	Unsigned8	rw	0	State definition after output error

7.3.4 Relation (Standard Mapping)

The relation of the application objects (Index 0x2000, 0x2100 and 0x5900) to the PDOs is different for Receive- (Rx-) and Transmit- (Tx-) PDOs.

7.3.4.1 Transmit PDO1 and 2

The Tx-PDO 1 is automatically defined according to Profile DS-401.

TxPDO1			
Idx	S-Idx	Value	Description
0x1A00	0	0x02	2 SubIndices are mapped
	1	0x60000108	Address 1. Digital input block (corresponds to Objekt 0x2000 0x01)
	2	0x60000208	Address 2. Digital input block (corresponds to Objekt 0x2000 0x02)
	3	0x00000000	Not mapped
	4	0x00000000	Not mapped
	5	0x00000000	Not mapped
	6	0x00000000	Not mapped
	7	0x00000000	Not mapped
	8	0x00000000	Not mapped

TxPDO2			
Idx	S-Idx	Value	Description
0x1A01	0	0x00	None SubIndices are gemapped
	1	0x00000000	Not mapped
	2	0x00000000	Not mapped
	3	0x00000000	Not mapped
	4	0x00000000	Not mapped
	5	0x00000000	Not mapped
	6	0x00000000	Not mapped
	7	0x00000000	Not mapped
	8	0x00000000	Not mapped

7.3.4.2 Receive PDO1 und 2

The first 2 Rx PDOs are automatically defined according to Profile DS-401.

RxPDO1			
Idx	S-Idx	Value	Description
1600	0	2	2 SubIndices are mapped
	1	6200 01 08	Address 1. Digital output block (corresponds toObjekt 0x2100 0x01)
	2	6200 02 08	Address 2. Digital output block (corresponds toObjekt 0x2100 0x02)
	3	0x00000000	Not mapped
	4	0x00000000	Not mapped
	5	0x00000000	Not mapped
	6	0x00000000	Not mapped
	7	0x00000000	Not mapped
	8	0x00000000	Not mapped

RxPDO2			
Idx	S-Idx	Value	Description
1601	0	0x00	None SubIndices are gemapped
	1	0x00000000	Not mapped
	2	0x00000000	Not mapped
	3	0x00000000	Not mapped
	4	0x00000000	Not mapped
	5	0x00000000	Not mapped
	6	0x00000000	Not mapped
	7	0x00000000	Not mapped
	8	0x00000000	Not mapped

7.3.5 Transmission Type (Operating mode)

For each PDO a mode of transmission (in index communication parameter) can be defined. Digital inputs are transmitted by default with 'Change of Value'(COV).

The kind of transmission dependent on the transmission type for digital inputs.

Transmission Type	PDO transmission					
	cyclic	acyclic	synchronous	asynchronous	RTR only	digital inputs
0		X	X			transmission for each SYNC, if COV
1 - 240	X		X			transmission for each x. SYNC
241 - 251	- reserved -					
252			X		X	request via RTR
253				X	X	request via RTR
254				X		COV
255				X		COV

The data are sent according to the configured Transmission Type of the modul.

Transmission Types	Meaning
0	The data is put out with the following Sync object, if they have been changed.
1 - 251	The data is put out with each n th SYNC object.
252	The data is put out with the following Sync object, if they have been requested in advance via a Remote Transmit Request Telegram (RTR).
253	The data is put out with each Remote Transmit Request Telegram (RTR).
254 and 255	The data is put out with each data change.

7.3.6 Inhibit Time

The inhibit time is taken into account only for transmit PDOs. The inhibit time is the blocking time between two transmit PDOs in periods of 100 μ s. The value is rounded off to the next ms. Values that are <1ms are stored as 0. In this case the module transfers the PDO as fast as possible.



Attention

In the transmission mode "change of value" (Transmission Types 254 and 255) with frequently changing input signals leads to a high bus load.

7.3.8 Error messages (Emergency)

Error messages are caused by an error situation e.g. a short circuit at the output. This emergency object is sent as a broadcast message by the module to all connected devices. If the error is cleared or the module is initialized again an emergency object is sent also. (Error Code = 0x0000, the Error Register and the Additional Code behave as described in DS 301).

The design and the meaning of the Emergency Object are described in table 4. The error code is coded low byte / high byte.

Byte:	0	1	2	3	7	
Name:	Error Code (low Byte first)		Error Register	Additional Code		Meaning
	-	-	-	-	-	Boot-Up Message, sent after power on and have no data bytes
	0x0000	0x00	0x00	0x00	00 00 00 00	The "predefined error field" Index 0x1003 SubIdx. 0 set to zero, internal - all errors are cleared, external - via corresponding SDO
	0x5000	0x81	0x81	0x00	01 00 00 00	Changed hardware configuration after power on or reset Node / communication The module is initialized, because no stored configuration is available.
	0x5000	0x81	0x81	0x00	03 00 00 00	EEPROM error Error during access on the EEPROM. Data could not be read or written. In this case the Default values will be loaded.
	0x6100	0x11	0x11	0x00	01 00 00 00	Internal receive / transmit buffer overflow; LED RX-/TXOVERF will be set; No state changing
	0x8100	0x81	0x81	0x00	02 00 00 00	The time between two Sync objects is greater than the Communication_Cycle_Period * Life_Time_Faktor. No state changing
	0x8100	0x81	0x81	0x00	03 SS II NN	PDO are sent with a number of bytes that are not configured in the communication profile. The PDO data are deleted, means the outputs are unchanged SS: Set value - configured value II: value - number of sent bytes NN: Number of the PDO (1...32)
	0x8110	0x11	0x11	0x00	00 00 00 00	A not read telegram is overwritten in the CAN Controller, LED RXOVERF will be set; No state changing
	0x8120	0x11	0x11	0x00	00 00 00 00	Error warning state, one of the CAN error counters attain the error warning limit; No state changing
	0x8130	0x11	0x11	0x00	01 00 00 00	The time between two node guarding telegrams is greater than Guard_Time * Life_Time_Faktor. Change to state PREPARED
	0x8140	0x11	0x11	0x00	00 00 00 00	After BusOff the node is again active at the network; No state changing
	0xFF00	0x05	0x05	0x01	AA BB 00 00	Output error (short circuit of one or more outputs, actuator supply failed, disturbance of a output driver) happens. The LED OVERLOAD is switched on until the error is cleared. AA: Diagnosis of the outputs 1-8 BB: Diagnosis of the outputs 9-16 A '1' at a bit location, indicates the failed output.
	0xFF00	0x81	0x81	0x00	03 00 XX 00	Unknown electronic module, Hardware error . - XX: identifier fieldbus PCB No PDOs and indices for the I/Os are prepared.

After Power On the module sends an emergency object with all Bytes = 0 to signal that the initialization is ready.

Another emergency object is sent if the loaded settings are default settings. There are two reasons for that:

- no settings are stored so far (Index 0x1010)
- The default setting are loaded (Index 0x1011)

7.3.8.1 Diagnosis messages of the outputs

The module monitors the output drivers and, in the event of an error, sends an emergency message containing the diagnosis information of the outputs. The diagnosis information is arrived at by a comparison of the put out status and the internally read back status. The following are causes for a diagnosis message to be activated:

- Missing current supply for the outputs
- Short circuit of an output
- Feed into an output
- Internal malfunction of an output level

The internal processing of the output information increases the duration of a pending diagnosis message to at least 1s. A set bit ('1') in the diagnosis byte means: "Diagnosis event pending at the output".

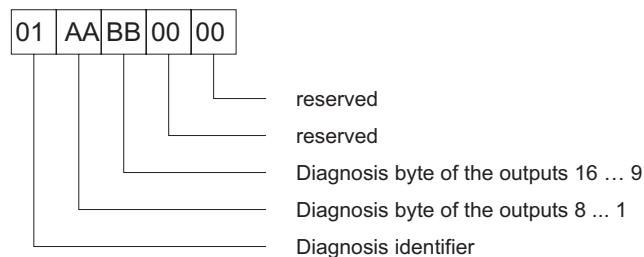

Fig. 7-1: Design of the Additional Code of the Diagnosis message

g112401e

Example:

The controls set the outputs 1, 2, 9, 10, 11, and 12 ('1'). The other outputs (3-16) are '0'.

A short circuit has occurred on output 2. A (+24V) voltage is fed in at output 3 due to an error. The power supply of outputs 9-16 is not switched on.

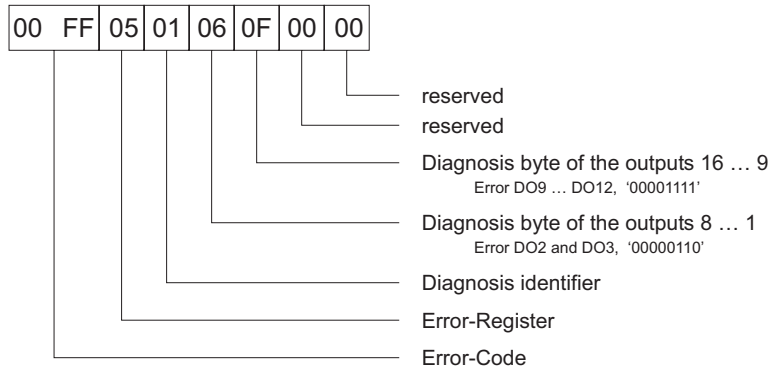

Fig. 7-2: Example Emergency telegram design

g112402e

7.3.9 Device Type, Index 0x1000

Index 0x1000 describes the Device Profile of the connected device. The "Device Profile for I/O Modules" (No. 401) is implemented in the CANopen module. The value in Index 0x1000 shows which kind of inputs and outputs are available.

Design:

Byte 3	Byte 2	Byte 1	Byte 0
0000.0000	0000.00XX	Device Profile Number 0x01 (High Byte)	Device Profile Number 0x91 (Low Byte)

Byte 2	Meaning
0000.00X1	Digital input available
0000.001X	Digital output available

7.3.10 Pre-defined Error Field, Index 0x1003

A maximum of 5 errors are entered in the error list. Sub-Index 0 contains the number of saved errors. On Sub-Index 1 always the error occurred last is shown. All previous errors are increased by a Sub-Index. If more than 5 errors occur, always the error on Sub-Index 5 is written over so that always the 5 errors are logged that have occurred last.

Design of the 4 byte error field (Sub-Index 1...5):

Byte 3	Byte 2	Byte 1	Byte 0
Additional Information (High Byte)	Additional Information (Low Byte)	Error code (High Byte)	Error code (Low Byte)

The additional information corresponds to the first 2 byte of the additional Code of the emergency telegram. The error code is like the error code in the emergency telegram.

If a '0' is written in the Sub-Index 0, the total error memory will be deleted.

7.3.11 Communication Cycle Period, Index 0x1006

This object defines the communication cycle period in μs . If the value is 0 the object is not evaluated. With help of the index the guarding of the sync objects is made if e.g. the node guarding can not be used. For a value >0 the module calculates a guarding time in which the next sync object is expected. If there is no sync object an emergency object is sent (Error code 0x8100). The module stays in the current state.

The guarding time is calculated of the communication cycle period (Index 0x1006, in μs) multiplied with the life time factor (index 0x100D). The resolution of the guarding time is in 1 ms steps.

If the life time factor is 0, only the Communication Cycle Period is relevant.

7.3.12 Store Parameter, Index 0x1010

The settings made by the user can be saved by writing the signature "save" (lower case letters ASCII - MSB 0x65 76 61 73 LSB) into index 0x1010 Sub-Index 1.

Once the module has completed the saving process, it transmits the SDO Response.

The following values are filed in the non volatile memory:

- COB-ID SYNC message
- Communication Cycle Period
- Synchronous Window Length
- Guard Time
- Life Time Factor
- Node Guarding Identifier
- COB-ID Emergency Message
- COB-ID Empfangs SDO
- COB-ID Sende SDO
- PDO Communication Parameter
- PDO Mapping Parameter

When a setting has been saved, the Emergency "Changed HW configuration" is not transmitted again during the next start-up of the module.

7.3.13 Load Parameter, Index 0x1011

By writing the signature "load" (lower letters ASCII - MSB 0x64 61 6F 6C LSB) in Index 0x1011 SubIndex 1 the factory settings are loaded. They are available after Power On until the next Power Off. Following this, the saved settings are loaded again. If the settings are not available on a permanent basis, they have to be saved again in index 0x1010, Sub-Index 1 using "save" (see standard CiA Draft Standard 301/ Version 3.0, page 10-25).

The standard factory settings are loaded by writing the signature "load" (lower case letters ASCII - MSB 0x64 61 6F 6C LSB) in the index 0x1011 Sub-Index 4. They remain valid until the next "save" command, irrespective of whether or not the module is switched off in between. Furthermore, following each Power On, the COB-IDs are created depending on the set Node-ID.

Example:

Set Node-ID: 3

Following a Power On the COB-ID of the RxPDO 1 is: 0x0183

Set Node-ID: 5

Following a Power On the COB-ID of the RxPDO 1 is: 0x0185

7.3.14 SYNC Guarding

The CANopen module optionally supports the SYNC object. The SYNC monitoring starts when the first SYNC telegram has been received and the module is in the "Operational" status.

The default setting of the SYNC monitoring is the switched off status, because a 0 is entered in the corresponding indexes (0x1006 = Communication Cycle Period, 0x100D = Life Time Factor).

7.3.14.1 Failure of a SYNC telegram

If no SYNC telegram is received within the monitoring period (Communication Cycle Period * Life Time Factor), the PREPARED LED indicates the operating status and no status change occurs. An emergency telegram (Error Code: 0x8100, Error Register: 0x81, Additional Code: 0x00 02 00 00 00) is sent. If a status change is instigated by the MASTER, SYNC telegram failure continues to be displayed.

It is not before a renewed receipt of the SYNC message that this status is left and an emergency telegram (Error Code: 0x0000, Error Register: 0x81, Additional Code: 0x00 02 00 00 00) sent to indicate that the SYNC monitoring is functional again.

7.3.15 Node Guarding

The CANopen module optionally supports node guarding. The node guarding starts for the module when the first Remote Transmit Request Telegramm (RTR) is received on the COB ID for Node Guarding (Index 0x100E). If the module does not receive a telegram the node guarding is not watched by the module. The Guarding node is switched off because a 0 is entered as a default value in the corresponding indices (0x100C = Guard-Time, 0x100D = Life Time Factor).

The NMT master polls the module at regular intervals. This period is termed Guard-Time (Index 0x100C). The internal status of the module is contained in the reply telegram.

In the event of the arrival of an RTR request without a guard time being set, the guarding node is not monitored, but the module responds with its internal status.

The state is coded as follows:

State:	Value:
Pre-Operational	127
Operational	5
Prepared	4

The life time is the product of guard time (Index 0x100C) multiplied by the Life Time Factor (Index 0x100D).

7.3.15.1 Failure of Node Guarding

If the Life Time is over without receiving a Node Guard Telegramm by the module, an emergency telegram (Error Code: 0x8130, Error Register: 0x11, Additional Code: 0x00 04 00 00 00) is set.

A failure of the Node Guarding is a communication error. A status change of the CANopen Software (Standard: PRE-OPERATIONAL) occurs according to the entry in the index 0x67FE Sub-Index 1, and the guarding failure is indicated by the LED flashing fast. The outputs are set according to index 0x6206 and 0x6207.

As soon as the Node Guarding Protocol starts again, the previous flashing code will be displayed, the module and the outputs stay in the state and a Emergency Telegram (Error Code: 0x0000, Error Register: 0x11, Additional Code: 00 04 00 00 00) will be sent, to indicate that the Node Guarding is re-started.

7.3.16 Diagnosis of the Outputs, Index 0x5900

The diagnosis information is switched active ('1'), when the status of an output pre-defined by the CANopen no longer coincides with the internally read back status. Each bit in the diagnosis byte is assigned to the corresponding bit in the output byte.

Causes for the activation of a diagnosis message:

- Missing power supply for the output classes
- Short-circuit of an output line
- Internal malfunction of an output class.

The internal processing of the output information extends a pending diagnosis message to a duration of at least 1s.

With diagnosis requests pending, the module sends an Emergency Message (Error Code: 0xFF00, Error Register: 0x81 Additional Code: 0x01 XX XX 00 00). Simultaneously the overload light diode is activated

7.3.17 Error Mode, Index 0x6206 and Error Value, Index 0x6207

The behavior of the outputs in the case of a communication error and of an output error can be set by means of the two indexes.

Communication errors are, amongst others:

- Bus Off of the CAN controller
- Guarding failure
- Change into the PRE-OPERATIONAL status.

Output errors are, amongst others:

- Missing power supply to the outputs which are set
- Short circuit of an output
- Feed into an output
- Internal malfunction of an output class

Each bit in index 0x6206 or 0x6207 corresponds to an output.

Index 0x6206 defines whether or not the current output value is maintained in the event of an error (bit set to 0) or the value in index 0x6207 is put out (bit set to 1).

The bit in index 0x6207 is put out at the corresponding output, if a communication error or an output error has occurred and if the attendant bit in index 0x6206 is set to 1.

Default setting: all bits in index 0x6206 are set to 1, and all bits in index 0x6207 are set to 0, i. e. in the case of an error, all outputs will be set to 0.

7.3.18 Error Behavior, Index 0x67FE

This index defines the status to which the CANopen software changes when a communication error (Sub-Index 1) or an output error (Sub-Index 2) occurs.

The behavior can be defined by means of the sub-indexes.

Value	Behavior
0	Change to the PRE-OPERATIONAL status when the current status is OPERATIONAL, otherwise the module's current status remains unchanged (default setting)
1	The module retains its current status.
2	Change to the PREPARED status

The module remains in this status even if the error is no longer pending. A status change is possible via NMT telegrams.

7.4 CANopen Telegrams

Following a Power On, the module is in the INITIALISATION status. In this status, the object directory is created and the application objects assigned to the PDOs. When successful, the module changes to the PRE-OPERATIONAL status.

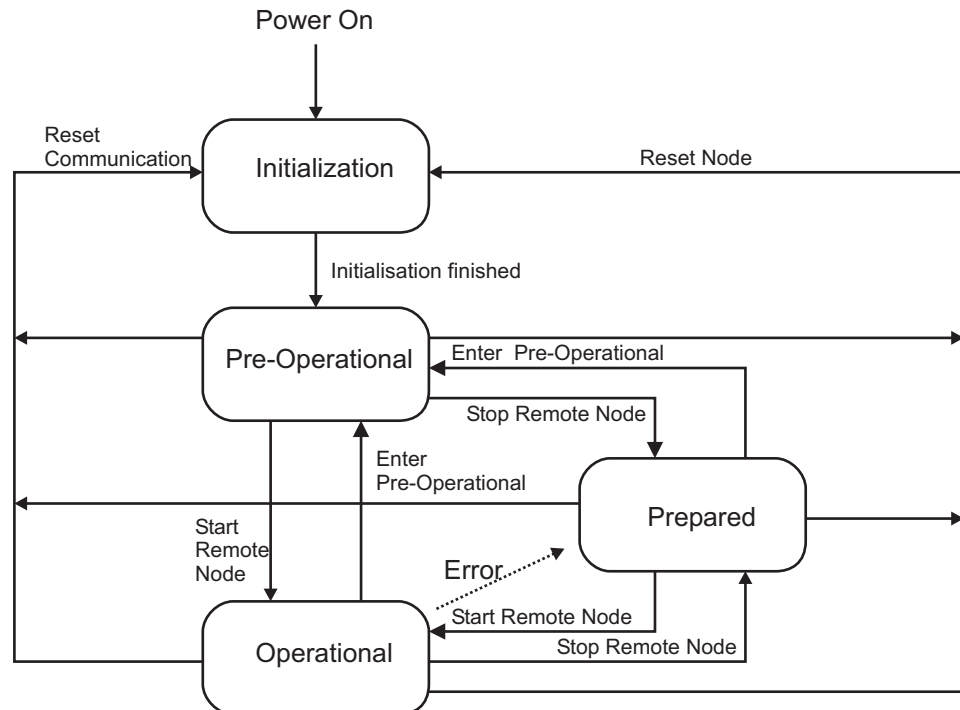

Fig. 7-3: State diagram

g012422x

As soon as the module is in the PRE-OPERATIONAL status, the communication can be made via SDOs. This status allows the following settings via SDOs:

- Setting the Guard-Time and the Life Time Factors.
- Setting the Communication parameter of the PDOs.
- Mapping of the PDOs.
- Saving the settings.
- Loading default settings.
- Register communication

An SDO is a CAL CMS object of the "Multiplexed Domain" type. With this object access to each object directory entry is possible. Transmission requires a certain protocol overhead containing the command specifier, index and sub-index of the entry to be read / written.

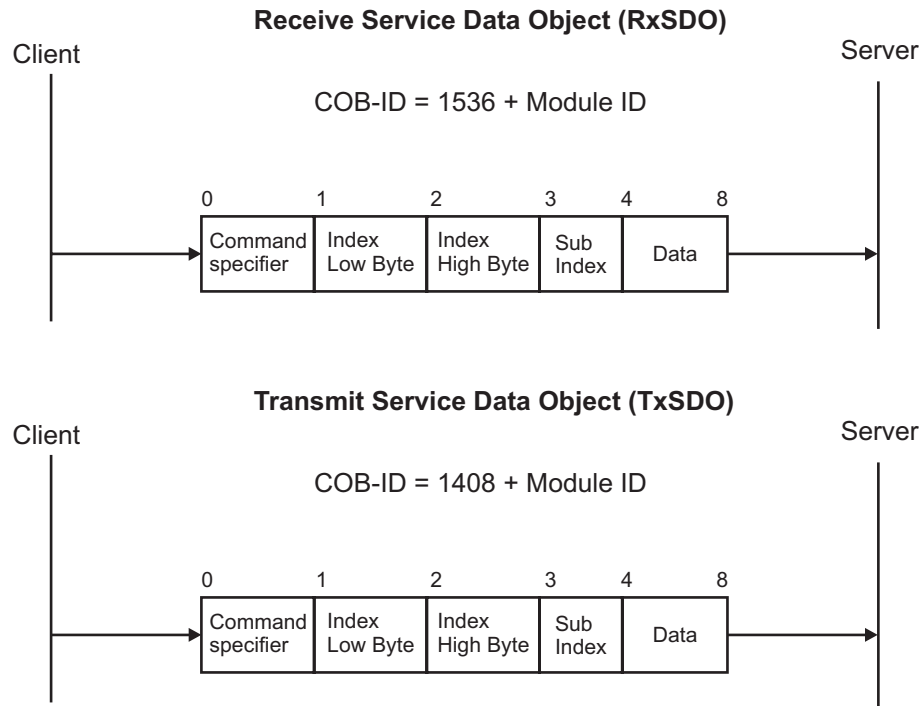

Fig. 7-4: SDO design

g012405x

Another object is available to allow a very quick transmission of data (without protocol overhead) - the Process Data Object (PDO).

PDOs consist only of the CAN identifier and the data field. No further protocol information is contained in a PDO, the design of the data field depending on the previously occurred mapping.

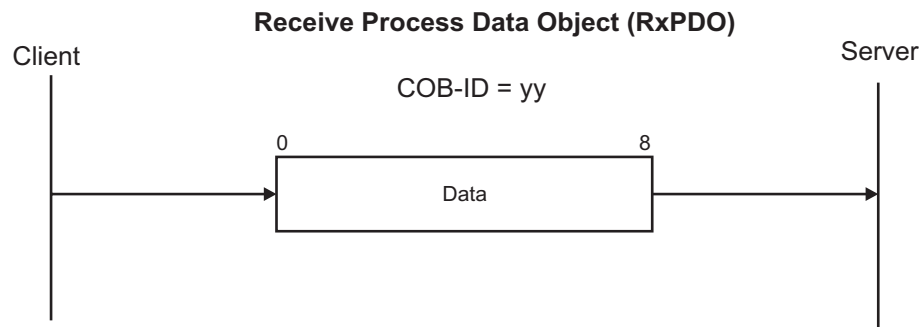

Fig. 7-5: RxPDO design

g*012403x

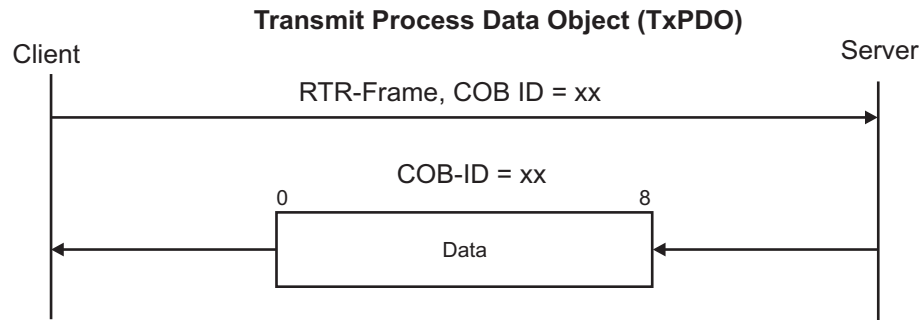

Fig. 7-6: TxPDO design

g*012404x

To be able to perform a process data exchange using PDOs, the module has to be brought into the OPERATIONAL status by means of the Service Start Remote Node. If TxPDOs are configured with the transmission type 254 or 255, the PDOs are sent with each change to the OPERATIONAL status. These PDOs are sent independent of an input data change.

Should an error occur, the module changes to the PREPARED status. In this status any communication via SDOs and PDOs is impossible. The module only reacts to the NMT services:

- Start Remote Node, change to the OPERATIONAL status, data transmission via SDOs and PDOs is possible.
- Enter Pre-Operational, change to the PRE-OPERATIONAL status, data transmission via SDOs is possible.
- Reset Node and
- Reset Communication, change to the INITIALISATION status, the settings saved last, or - if nothing different has been saved - the factory default settings are loaded. Following this, the module changes to the PRE-OPERATIONAL status.

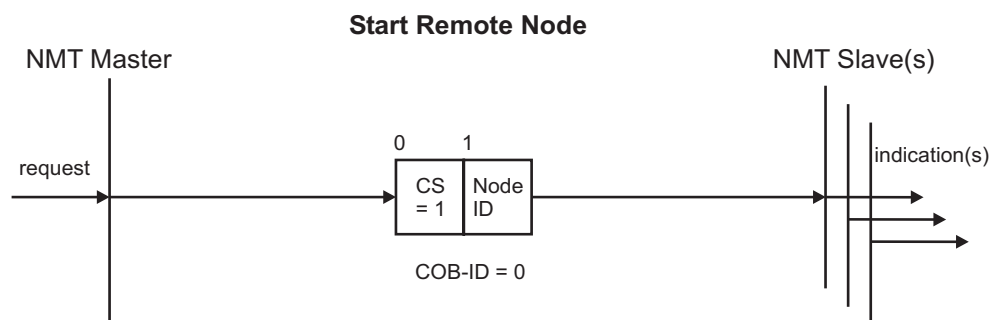

Fig. 7-7: Design of NMT Services, Start Remote Node

g012415x

Node ID = 0: All existing nodes change to the OPERATIONAL status.

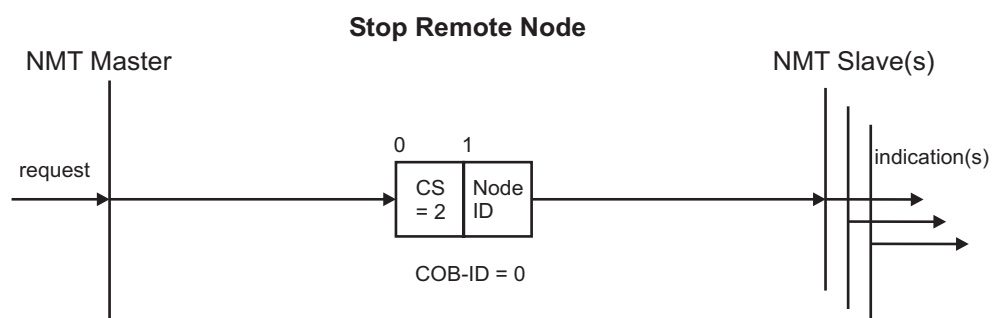

Fig. 7-8: Design of NMT Services, Stop Remote Node

g012416x

Node ID = 0: All existing nodes change to the PREPARED status.

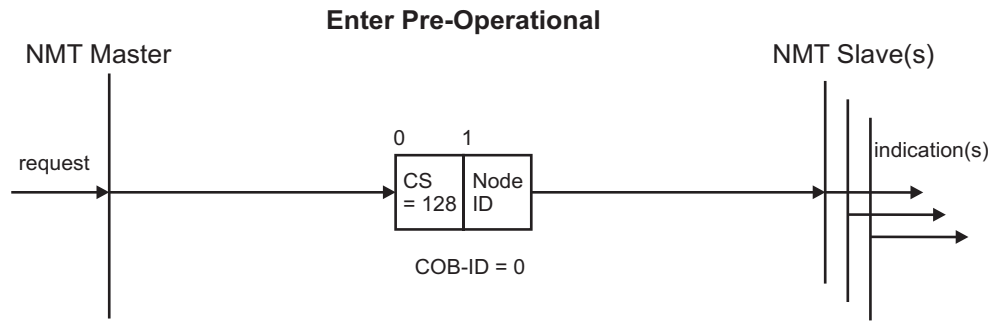

Fig. 7-9: Design of NMT Services, Pre Operational State

g012417x

Node ID = 0: All existing nodes change to the PRE-OPERATIONAL status.

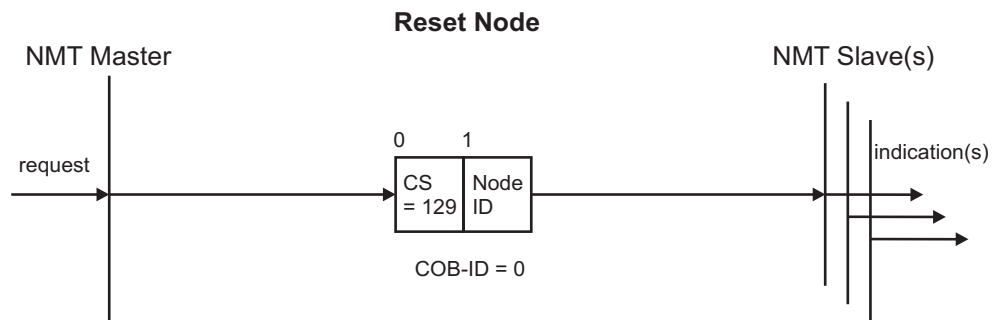

Fig. 7-10: Design of NMT Services, Reset Node

g012418x

Node ID = 0: A reset is performed with all existing nodes.

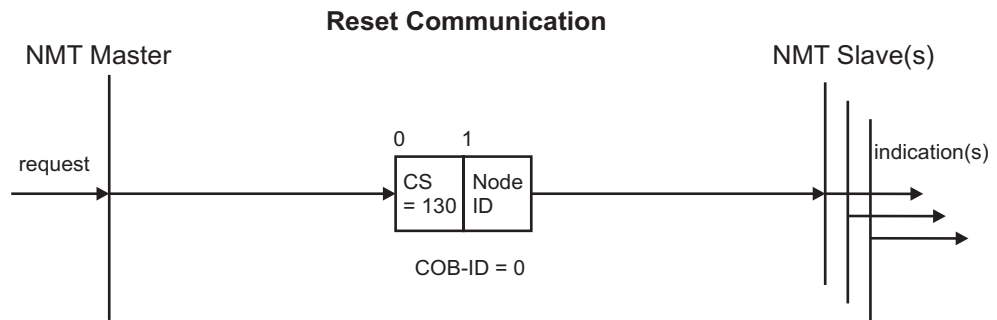

Fig. 7-11: Design of NMT Services, Reset Communication

g012427x

Node ID = 0: A reset is performed with all existing nodes.

7.5 PDO Mapping

Sequence:

- The module must be in the PRE-OPERATIONAL status.
- PDO deactivation by writing SubID 1 = 0x80 00 00 00 in the Communication Record.
- A 0 is entered in the mapping parameter structure sub-index 0 in order to de-activate the mapping parameters.
- Entry of index, sub-index and object length of the application object into the mapping parameter structure. A maximum of 8 byte data can be assigned per PDO.
- The number of the application objects used is entered in the mapping parameter structure sub-index 0.
- Entry of the communication parameter sub-indexes 1-3 into the communication parameter structure.
- Change the module to the OPERATIONAL status (Start_Remote_Node)
- PDOs are active.

7.5.1 The Indices of the PDO Mapping

7.5.1.1 Communication parameter

Used COB-ID of the PDO, Design: Communication Record Sub-Index: 1

Bit	Value	Meaning
0 - 10		Bit 0 - 10 der COB-ID
11-28		Bit 11 - 28 der COB-ID (if Bit 29 = 1)
29	0 1	ID: 11-Bit ID 29-Bit ID
30	0 1	RTR on this PDO allowed not allowed
31	0 1	PDO valid not valid

Transmission Type, Design: Communication Record, Sub-Index: 2

Transmission type	PDO transmission				
	cyclic	acyclic	synchronous	asynchronous	RTR only
0		X	X		
1-240	X		X		
241-251	reserved				
252			X		X
253				X	
254				X	
255				X	

7.5.1.2 PDO Mapping parameter

Design: PDO Mapping Entry, Sub-Index: 0x01-0x08

Bit	Value	Meaning
0 - 7		Object length
8-15		Sub-Index
16-31		Index



Note

One object entry can be mapped in max. 2 differnt valid PDOs.

7.6 Example PDO Mapping

The inputs 9 to 16 (2nd digital input byte) and the diagnosis byte of the outputs 1 - 8 are to be mapped using the TxPDO 2. The CAN identifier 0x432 is to be used for transmission which is to be performed synchronous with each 3rd SYNC object.

The default CAN IDs for the SDOs are used. The setting is made at node 8.

xx - are not evaluated

TxPDO 2:

Index for the Communication Record: 0x1801

Index for the Mapping Parameter Structur: 0x1A01

PDO deactivating:

Write via SDO the value 0x80 00 00 00 in the Index 0x1801 Sub-Index 01.		
	CAN ID	Data
Send	0x608	0x23 01 18 01 00 00 00 80
Receive	0x588	0x60 01 18 01 xx xx xx xx

Mapping deactivating:

Set number of Mapping objects in Sub-Index 0 = 0		
	CAN ID	Data
Send	0x608	0x2F 01 1A 00 00 xx xx xx
Receive	0x588	0x60 01 1A 00 xx xx xx xx

Mapping Parameter Structure overwriting:

The data are available via the following application objects.

application object:	Index	Sub-Index
2. digital input byte	0x2000	2
1. Diagnosis byte	0x5900	1

The following structure has to be achieved in the mapping parameters of the 2nd TxPDO to be able to realize the task.

TxPDO Mapping Parameter Structure, Index 0x1A01			
Sub-Index:	application object		Object length in Bit
	Index:	Sub-Index:	
0	2		
1	0x2000	2	0x08
2	0x5900	1	0x08

These objects are saved by means of SDO transmissions:

2. Mapping digital input byte		
	CAN ID	Data
Send	0x608	0x23 01 1A 01 08 02 00 20 23 0 Datenbytes ungültig 011A Index (low byte first) 01 Sub-Index 08 Data width of the input 02 Sub-Index, where the 2. input locates in the Manufacturer Device Profile 00 20 Index (low byte first) where the 2. input locates in the Manufacturer Device Profile
Receive	0x588	0x60 01 1A 01 xx xx xx xx 60 OK 011A Index(Lowbyte first) 01 Sub-Index

1. Mapping diagnosis byte		
	CAN ID	Data
Send	0x608	0x23 01 1A 02 08 01 00 59
Receive	0x588	0x60 01 1A 02 xx xx xx xx

Number of mapping objects = 2, set on Sub-Index 0		
	CAN ID	Data
Send	0x608	0x2F 01 1A 00 02 xx xx xx
Receive	0x588	0x60 01 1A 00 xx xx xx xx

Setting the Communication Parameter:

The Transmission Type is 3 (Synchronous transmission with each 3. SYNC-Object).

TxPDO Communication Parameter, Index 0x1801		
Sub-Index	Value	Meaning
0	3	number of supported entries in the record
1	32 04 00 00	COB-ID used by PDO
2	3	Transmission Typ
3	0	Inhibit Time

Inhibit Time = 0		
	CAN ID	Data
Send	0x608	0x2B 01 18 03 00 00 xx xx
Receive	0x588	0x60 01 18 03 xx xx xx xx

Transmission Type = 3		
	CAN ID	Data
Send	0x608	0x2F 01 18 02 03 xx xx xx
Receive	0x588	0x60 01 18 02 xx xx xx xx

Define COB ID = 432 of the PDO and set PDO from invalid to valid		
	CAN ID	Data
Send	0x608	0x23 01 18 01 32 04 00 00
Receive	0x588	0x60 01 18 01 xx xx xx xx

Start PDO Transmission

Set the module with the telegram "Start Remote Node" into the state OPERATIONAL. The Tx PDO Object is now useable for data transmission.

7.7 Default Process Data Input Image

Byte	Bit	Bit	Bit	Bit	Bit	Bit	Bit	Bit
0	Discret Input8	Discret Input7	Discret Input6	Discret Input5	Discret Input4	Discret Input3	Discret Input2	Discret Input1
1	Discret Input16	Discret Input15	Discret Input14	Discret Input13	Discret Input12	Discret Input11	Discret Input10	Discret Input9
2	Status8	Status7	Status6	Status5	Status4	Status3	Status2	Status1
3	Status 16	Status 15	Status 14	Status 13	Status 12	Status 11	Status 10	Status 9

7.8 Default Process Data Output Image

Byte	Bit	Bit	Bit	Bit	Bit	Bit	Bit	Bit
0	Discret Output8	Discret Output7	Discret Output6	Discret Output5	Discret Output4	Discret Output3	Discret Output2	Discret Output1
1	Discret Output16	Discret Output15	Discret Output14	Discret Output13	Discret Output12	Discret Output11	Discret Input10	Discret Input9



Further Informationen

CAN in Automation (CiA) provides for members further documentation in the INTERNET.

can-cia.de

7.9 EDS files

The performance features of the devices are documented by the manufacturers and passed on to the user under CANopen in the form an EDS file (Electronic Data Sheet).

Design, contents and coding of the EDS fields are standardized allowing projecting with projecting devices supplied by different manufacturers.



Further information

EDS and symbol files for the configuration of the I/O modules are available under the order number 750-914, either on a disc, or can be downloaded from WAGO's INTERNET homepage.

<http://www.wago.com/>

EDS file for I/O-Module 750-327	750-327.eds
---------------------------------	-------------

The EDS file is read by the configuration software, and corresponding settings are transmitted. For necessary inputs and steps to take, please refer to the software user manuals.

7.10 Configuration

In preparation

7.11 Fieldbus Controller Boards

Master control systems such as PLC's communicate to fieldbus devices on a network via fieldbus controller boards. WAGO offers the WAGO-I/O-SYSTEM 758 PC Interface PCB fieldbus controller board.

Fieldbus controller boards for programmable logical controls are available from other manufacturers.

7.12 Configuration Software

Before a PLC can communicate I/O data with a fieldbus device, the fieldbus controller board has to be configured for each field bus device on the network.

To accomplish this, the WAGO-I/O-SYSTEM 758 fieldbus controller board is delivered with WAGO *NETCON* software for configuring and diagnosing fieldbus networks.



Further Informationen

EDS and Symbol files for the configuration of I/O modules available with the item no. 750-914 on floppy disk or on the INTERNET Site of WAGO.

<http://www.wago.com>

8 Accessories

Accessories	Article No.	Pcs. per packing unit
EDS files (floppy disk)	750-914	1
Marking label 16 DI/16DO	752-102	1 sheet (9 labels)
Replacement fuse F1 (TR 5 / 250 V / 6.3A T) Micro-fuse according to IEC 127-3 Note: Use UL-Recognized fuse only	752-180	5
Felt tipped pen for non-smudge writing	210-110	1
Operating tool (screw driver)		
- Blade (2.5x0.4) mm	210-119	1
- Blade (3.5x0.4) mm	210-120	1
- with part.insulated shank, blade (2.5x0.4) mm	210-619	1
- with part.insulated shank, blade (3.5x0.4) mm	210-620	1



WAGO Kontakttechnik GmbH
Postfach 2880 • D-32385 Minden
Hansastraße 27 • D-32423 Minden
Phone: +49 (0) 5 71/8 87 – 0
Telefax: +49 (0) 5 71/8 87 – 1 69
E-Mail: info@wago.com

Internet: <http://www.wago.com>
