

Block diagram of an output

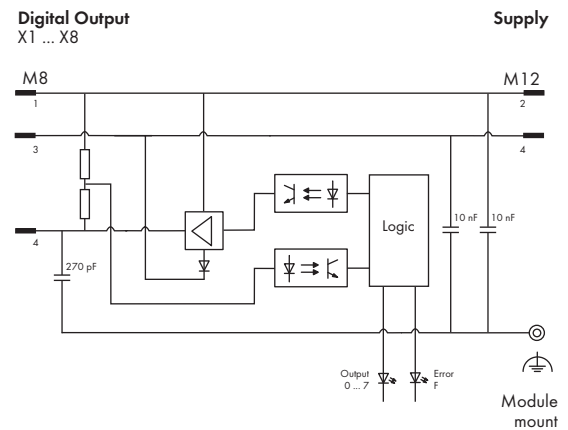

Technical Data

Information on actuator selection:

Delay time hardware from "0" to "1" (0 - 90%)	Typ. 75 µs (resistive load)
Delay time hardware from "1" to "0" (0 - 90%)	Typ. 265 µs (resistive load)
Rise time from "0" to "1"	Typ. 30 µs (resistive load)
Fall time from "1" to "0"	Typ. 50 µs (resistive load)
Cable length, unshielded	≤ 30 m
Protection against reverse voltages	≤ 2 A
Type of load	Inductive, resistive loads and lamps
Switching frequency	Inductive load approx. 20 Hz Resistive load approx. 500 Hz Lamp load approx. 500 Hz
Parallel connection of 2 outputs	for power boost for redundant actuation of a load
Type of protective circuit	External protection (e.g., recovery diodes) required
Output resistance	max. 0.1 Ω

Operating state influence on output:

PLC CPU stop	Acc. to substitute value strategy
Fieldbus disruption	Acc. to substitute value strategy
S-bus (system bus) disruption	0 V status
Supply voltage under rated voltage tolerance	0 V status
Interruption of supply voltage	0 V status
Output operation	Non-latching
Overload behavior	Automatic restart

System bus:

Connection type (3)	M12 connectors, B coded, 5 poles, shielded
---------------------	--

Standards and approvals:

Conformity marking	CE
Korea Certification	
UL 508	
BVS 15 ATEX E 098 X	II 3G Ex nA IIC T5 Gc, II 3D Ex tc IIIB T90°C Dc
IECEX BVS 15.0083X	Ex nA IIC T5 Gc, Ex tc IIIB T90°C Dc

Technical Data

Isolation:

Channel - Channel	No
U _{LS} , U _A , system bus	500 V DC each

Configurable functions:

Inversion (per channel)	On/off
Substitute value strategy (per channel)	Switch substitute value/hold last value
Substitute value (per channel)	0/1
Manual mode (per channel)	On/off
Manual mode value (per channel)	0/1
Online simulation (per channel)	Lock/unlock; simulation value: 0/1
Online simulation (per channel/module)	Diagnostics

I/O diagnostics:

I/O diagnostics (per channel)	Actuator short-circuit/overload Actuator wire break Overtemperature
I/O diagnostics (per module)	Undervoltage (U _{LS} + U _A)

Process image:

Process data width	1-byte data + status
--------------------	----------------------

LED indicators:

SB: System bus status	LED (green/red/orange)
F: Error status	LED (red)
0 ... 7: Output signal status	LED (yellow/red)
U _{LS} + U _A : Supply status	LED (green)
Indicators	Non-latching

General Specifications

Dimensions (mm) W x H x L	50 x 35.7 x 117
Weight	277 g