

WAGO-SPEEDWAY 767

Manual



767-4803/000-800
8DO 24V DC 2.0A IF (8xM8)
Digital Output Module 24 V DC / 2.0 A

Version 1.1.0

© 2016 by WAGO Kontakttechnik GmbH & Co. KG
All rights reserved.

WAGO Kontakttechnik GmbH & Co. KG

Hansastraße 27
D-32423 Minden

Phone: +49 (0) 571/8 87 – 0
Fax: +49 (0) 571/8 87 – 1 69

E-Mail: info@wago.com

Web: <http://www.wago.com>

Technical Support

Phone: +49 (0) 571/8 87 – 5 55
Fax: +49 (0) 571/8 87 – 85 55

E-Mail: support@wago.com

Every conceivable measure has been taken to ensure the accuracy and completeness of this documentation. However, as errors can never be fully excluded, we always appreciate any information or suggestions for improving the documentation.

E-Mail: documentation@wago.com

We wish to point out that the software and hardware terms as well as the trademarks of companies used and/or mentioned in the present manual are generally protected by trademark or patent.

Table of Contents

1	Notes about this Documentation.....	6
1.1	Validity of these Operating Instructions	6
1.2	Copyright.....	6
1.3	Symbols.....	7
1.4	Number Notation.....	9
1.5	Font Conventions	9
2	Important Notes	10
2.1	Legal Bases	10
2.1.1	Subject to Changes	10
2.1.2	Personnel Qualification	10
2.1.3	Use in Compliance with Underlying Provisions	11
2.1.4	Technical Condition of Specified Devices	11
2.2	Safety Advice (Precautions).....	12
2.3	Safety Equipment	13
2.4	Notes on Operation	14
3	Device Description	15
3.1	Connectors.....	16
3.2	Marking Possibilities and Fastening	17
3.3	Display Elements	18
3.4	Labeling.....	19
3.5	Schematic Diagram	21
3.6	Dimensions.....	22
3.7	Technical Data	23
3.7.1	General Information	23
3.7.2	Supply.....	23
3.7.3	Communication	23
3.7.4	Outputs	24
3.7.5	Information on Selecting the Actuator	25
3.7.6	Influence of Operating States on Output	25
3.7.7	Configurable Functions	26
3.7.8	Diagnostics	26
3.7.9	Process Image.....	26
3.7.10	Display Elements.....	26
3.7.11	Isolation	26
3.8	Approvals	27
3.9	Standards and Guidelines	28
4	Mounting.....	29
4.1	Information on Mounting.....	29
4.2	Tools and Accessories Required for Mounting.....	31
4.3	Direct Mounting on Your System	32
4.4	Mounting on a Carrier Rail (only with WAGO Accessories).....	33
4.4.1	Fastening the Carrier Rail Adapter to the Module	33
4.4.2	Fastening the Module with Carrier Rail Adapter to a Carrier Rail	34
4.5	Mounting on a Profile Rail (only with WAGO Accessories)	35
4.5.1	Fastening the Profile Adapter to the Module	35

4.5.2	Fastening the Module with Profile Adapter to a Profile Rail	36
4.6	Marking and Replacing the Marking Spaces	37
4.7	Mounting the Spacer in the Case of Compact Arrangement.....	38
5	Connecting Data and Supply Cables.....	40
5.1	Notes	40
5.2	Required Accessories	41
5.3	Connecting the S-BUS Cables	42
5.4	Connecting the Supply Cable.....	44
5.5	Connecting the Actuator Cable	46
6	Commissioning	48
7	Parameterizing	49
7.1	Electronic Type Label	51
7.2	Diagnostic Overview	52
7.3	Parameters of Outputs	54
7.4	Global Settings	56
7.5	Automatic Storage of System Parameters	57
7.6	Updating the Firmware	57
8	Process Image	58
8.1	Output Data	59
8.2	Input Data.....	61
9	Diagnostics	63
9.1	LED Signaling.....	63
10	Service	66
10.1	Updating the Firmware	66
10.2	Replacing the Module	66
10.2.1	Disconnecting the Cables	66
10.2.2	Removing the Module from Your System	67
10.2.3	Removing the Module from the Carrier Rail	67
10.2.4	Removing the Module from the Profile Adapter.....	68
10.2.5	Connecting the Module	68
10.3	Disposal.....	68
11	Use of the Interference-Free Module in Safety Applications.....	69
11.1	Important Notes.....	69
11.2	General Measures and Conditions for the Power Supply Solution of the Module.....	70
11.3	Measures and Conditions for Shielded Power Supply of the Module	72
11.4	Measures and Conditions for Unshielded Power Supply of the Module	73
11.5	Connection of the Module to Safety Switching Devices	74
11.5.1	General Structure of a Potential Group	74
11.5.2	Examples of Connection.....	75
12	Appendix.....	76
12.1	Diagnostic Information	76
	List of Figures	77

List of Tables..... 78

1 Notes about this Documentation

The module shall only be installed and operated in conjunction with these operating instructions and the system description.

WARNING

Observe release notes!

Please note that, within the SPEEDWAY system, a function is provided **without restriction** only if all system's components have the same system-wide firmware release. Therefore, always observe the appropriate release notes on products used.

NOTICE

Supply layout!

In addition to these operating instructions, you will need the “WAGO *SPEEDWAY 767*, System Description and Information” manual, which can be downloaded at www.wago.com. There you will find information regarding supply layout, etc.

Note



Always retain this documentation!

This documentation is part of the product. Therefore, retain the documentation during the entire service life of the product. Pass on the documentation to any subsequent user. In addition, ensure that any supplement to this documentation is included, if necessary.

1.1 Validity of these Operating Instructions

These operating instructions are only applicable to the WAGO *SPEEDWAY 767* Series module 8DO 24V DC 2.0A IF (8xM8), 767-4803/000-800.

1.2 Copyright

This Manual, including all figures and illustrations, is copyright-protected. Any further use of this Manual by third parties that violate pertinent copyright provisions is prohibited. Reproduction, translation, electronic and phototechnical filing/archiving (e.g., photocopying) as well as any amendments require the written consent of WAGO Kontakttechnik GmbH & Co. KG, Minden, Germany. Non-observance will involve the right to assert damage claims.

1.3 Symbols

 **DANGER**

Personal Injury!

Indicates a high-risk, imminently hazardous situation which, if not avoided, will result in death or serious injury.

 **DANGER**

Personal Injury Caused by Electric Current!

Indicates a high-risk, imminently hazardous situation which, if not avoided, will result in death or serious injury.

 **WARNING**

Personal Injury!

Indicates a moderate-risk, potentially hazardous situation which, if not avoided, could result in death or serious injury.

 **CAUTION**

Personal Injury!

Indicates a low-risk, potentially hazardous situation which, if not avoided, may result in minor or moderate injury.

NOTICE

Damage to Property!

Indicates a potentially hazardous situation which, if not avoided, may result in damage to property.

NOTICE

Damage to Property Caused by Electrostatic Discharge (ESD)!

Indicates a potentially hazardous situation which, if not avoided, may result in damage to property.

Note

Important Note!

Indicates a potential malfunction which, if not avoided, however, will not result in damage to property.

Information



Additional Information:

Refers to additional information which is not an integral part of this documentation (e.g., the Internet).

1.4 Number Notation

Table 1: Number Notation

Number Code	Example	Note
Decimal	100	Normal notation
Hexadecimal	0x64	C notation
Binary	'100' '0110.0100'	In quotation marks, nibble separated with dots (.)

1.5 Font Conventions

Table 2: Font Conventions

Font Type	Indicates
<i>italic</i>	Names of paths and data files are marked in italic-type. e.g.: <i>C:\Program Files\WAGO Software</i>
Menu	Menu items are marked in bold letters. e.g.: Save
>	A greater-than sign between two names means the selection of a menu item from a menu. e.g.: File > New
Input	Designation of input or optional fields are marked in bold letters, e.g.: Start of measurement range
“Value”	Input or selective values are marked in inverted commas. e.g.: Enter the value “4 mA” under Start of measurement range .
[Button]	Pushbuttons in dialog boxes are marked with bold letters in square brackets. e.g.: [Input]
[Key]	Keys are marked with bold letters in square brackets. e.g.: [F5]

2 Important Notes

This section includes an overall summary of the most important safety requirements and notes that are mentioned in each individual section. To protect your health and prevent damage to devices as well, it is imperative to read and carefully follow the safety guidelines.

2.1 Legal Bases

2.1.1 Subject to Changes

WAGO Kontakttechnik GmbH & Co. KG reserves the right to provide for any alterations or modifications that serve to increase the efficiency of technical progress. WAGO Kontakttechnik GmbH & Co. KG owns all rights arising from the granting of patents or from the legal protection of utility patents. Third-party products are always mentioned without any reference to patent rights. Thus, the existence of such rights cannot be excluded.

2.1.2 Personnel Qualification

All sequences implemented on the module may only be carried out by electrical specialists with sufficient knowledge in automation. The specialists must be familiar with the current standards and guidelines for the module and automation environment.

2.1.3 Use in Compliance with Underlying Provisions

The module 767-4803/000-800 emits digital signals that are specified by a higher-level controller, e.g., a programmable fieldbus coupler.

The module may not be used to control safety-related functions, i.e. it cannot be a functional part of a safety function.

The digital outputs of the module are interference-free to eliminate any impact by the internal potential groups.

In a safety circuit, the module shall only be used together with a safety switching device (with diagnostic function).

If additional modules are required, these modules must also be interference-free. The module itself is no safety-oriented module. Note the "Use of the Interference-Free Module in Safety Applications" chapter.

The module may only be operated in combination with components of the WAGO *SPEEDWAY 767* Series.

The module was developed for applications requiring IP 67 (NEMA type 6, 6P) protection.

Applications other than those described in this manual are not permitted.

2.1.4 Technical Condition of Specified Devices

The devices to be supplied ex works are equipped with hardware and software configurations, which meet the individual application requirements. WAGO Kontakttechnik GmbH & Co. KG will be exempted from any liability in case of changes in hardware or software as well as to non-compliant usage of devices.

Please send your request for modified and new hardware or software configurations directly to WAGO Kontakttechnik GmbH & Co. KG.

2.2 Safety Advice (Precautions)

DANGER



Electric voltage!

Operate the 767 Series components exclusively with 24 VDC PELV (Protective Extra Low Voltage) or SELV (Safety Extra Low Voltage) voltage sources. Failure to comply may result in electric shock.

CAUTION



Hot connection sockets!

Even when taking into account derating, high surface temperatures on the metallic connection sockets and on the enclosure can arise during operation. If the 767 Series component has been in operation, allow it to cool off before moving it.

NOTICE

The highest current carrying capacity of the supply contacts is 4 A!

Always observe the maximum current carrying capacity per supply line (U_{LS} , U_A) for each 767 Series component and the overall power consumption for all 767 components. Neither of these values shall exceed 4 A since an increase in current causes the contacts to overheat and damages the 767 Series components. Information regarding the power demand of each 767 Series component can be found in the corresponding data sheet, which is available from www.wago.com.

NOTICE

Exposed connections!

If connections have not been closed with protective caps, liquid or dirt can penetrate the components of the 767 Series module and ruin it. Therefore, close all unnecessary connections with protective caps, which must be ordered separately, in order to maintain the IP67 degree of protection. (See section “Accessories” of the fieldbus coupler/controller manual.)

- Disconnect the power supply from the system on which you wish to mount the 767 Series device.
- Observe the appropriate accident prevention regulations for your system during assembly, start-up, maintenance, and repairs. For example, BGV A3, “Electrical systems and equipment”.
- The operating instructions for the 767 Series module and the system description must be laid out ready on site.
- Observe the exact positioning (coding) between plug and socket.
- The 767 Series device shall not come into contact with substances having seeping and insulating properties. Otherwise, additional measures shall be

taken for the device, such as installation of an enclosure that is resistant to the above-mentioned substance properties.

- Electronic components fulfilling the ESD requirements according to the IEC 61000-6-2 are integrated in the 767 device. As higher voltages may occur, under unfavorable circumstances, due to electrical charge in the field, discharge must be ensured before performing work on the 767 system.
- Ensure that the potential equalization is correctly laid out.
- Keep all cables a sufficient distance away from electromagnetic sources of interference in order to maintain a high level of interference resistance of the 767 system against electromagnetic emissions. Use only shielded cables at the necessary locations, and always observe the appropriate standards for EMC-suitable installations.
- For the power supply and for the S-BUS, use only pre-assembled WAGO system cables, so the specified characteristics of the technical data can be achieved.
- Replace defective or damaged modules (e.g., deformed connections), else function disruptions can occur in the respective fieldbus stations or nodes.
- When laying any cables, make sure that you do not lay them within the shear range of movable machine parts.
- For each activity, observe the corresponding personnel qualification in the corresponding section.
- Observe the marking on the front and rear side of the module.

2.3 Safety Equipment

All 767 Series products are designed to meet the requirements of IP67. This includes complete protection against accidental contact with electrical voltage and currents – even when wet.

2.4 Notes on Operation

When integrating the 767 module in your machine or system, all the currently applicable norms, regulations and guidelines shall be observed during all activities: for example, BGV A3, “Electrical systems and equipment”, DIN EN 418, EN 60204. The emergency stop equipment shall remain effective in all operating modes of the system and machine.

For protection from electromagnetic interferences

- Connect your system to protective earth (PE), and
- Ensure that the cable routing and the installation of the fieldbus cable, S-BUS cable, supply cable, and sensor or actuator cable are correct.

The following elements for 24 V supply shall be present:

- Outer lightning protection on buildings
- Inner lightning protection of supply lines and signal lines
- Safe electrical separation of low voltage 24 VDC through PELV (Protective Extra Low Voltage) or SELV (Safety Extra Low Voltage) voltage sources

3 Device Description

The digital output module 767-4803/000-800 is used to control solenoid valves, gates, transmitters, relays or other electrical loads. The module has many parameterization options that can be carried out via a fieldbus coupler. In addition, diagnostic messages for individual channels and for the entire module can be parameterized.

Use a fieldbus or FDT-DTM as, for example, with the WAGOframe to make module settings. Detailed information about assignment of module parameters using a fieldbus can be found in the corresponding manual.

Detailed information regarding the properties of the module is available in Section "Technical Data".

3.1 Connectors

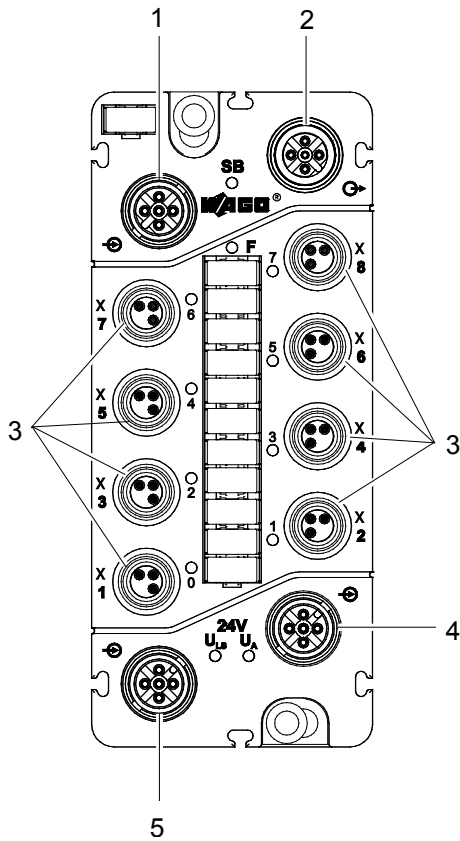

Figure 1: Connectors (exemplary)

Table 3: Legend for figure "Connectors"

Position	Description	Function
1	S-BUS input M12 plug, B-coded	For transmitting data from previous 767 Series components.
2	S-BUS output M12 socket, B-coded	For transmitting S-BUS data to the next 767 Series components or to the S-BUS terminator.
3	Digital outputs X1 – X8 M8 socket	For connecting digital actuators (e.g., solenoid valves or gates).
4	Supply input M12 plug, A-coded	For feeding in both U_{LS} (logic and sensor supply) and U_A (actuator supply).
5	Supply input M12 plug, A-coded	

3.2 Marking Possibilities and Fastening

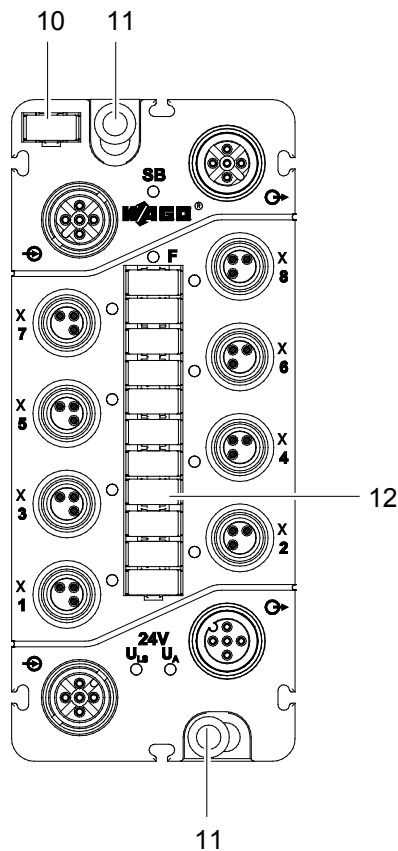

Figure 2: Marking possibilities and fastening (exemplary)

Table 4: Legend for figure "Marking possibilities and fastening"

Position	Description	Function
10	Module marker card	For identifying the module within a fieldbus node.
11	Mounting holes	With integrated function earth (FE) socket for fastening and grounding the module.
12	Marker strips	For identifying inputs.

3.3 Display Elements

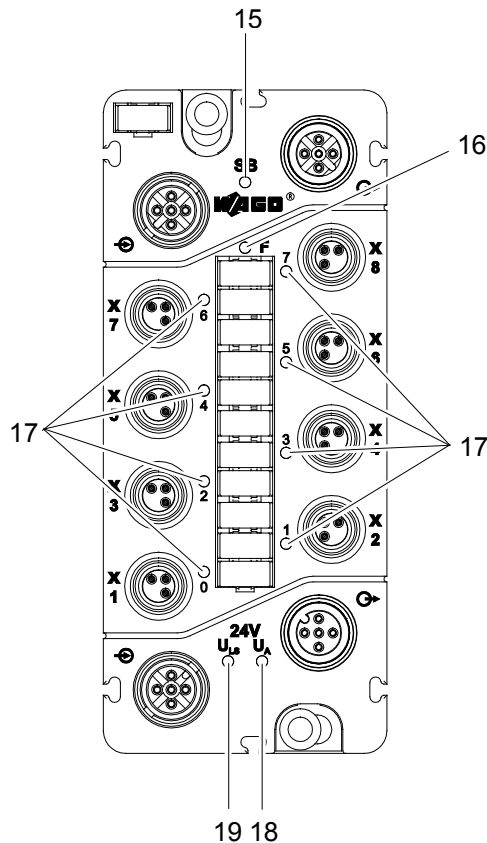

Figure 3: Display elements (exemplary)

Table 5: Legend for figure "Display elements"

Position	LED	Color	Meaning
15	SB	Green/red/orange	S-BUS status
16	F	Red	Diagnostic information
17	0 ... 7	Yellow/red	Information on outputs
18	U_A	Green	Actuator supply is present.
19	U_{LS}	Green	Logic supply and sensor supply are present.



Note

Detailed information

Detailed information can be found in section "Diagnostics" > "LED Signaling".

3.4 Labeling

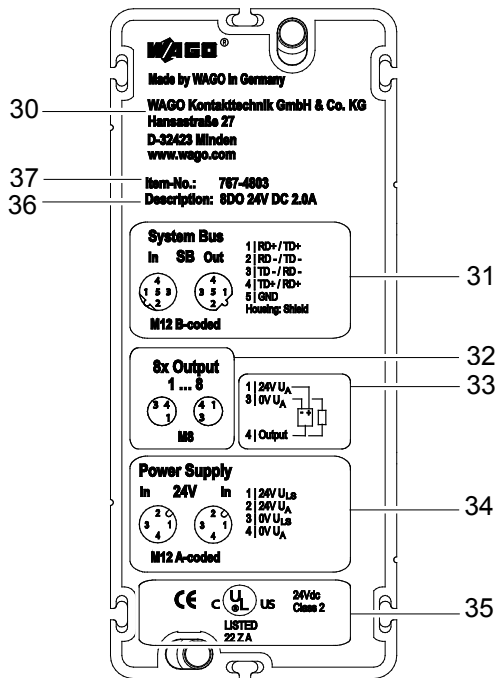

Figure 4: Labeling (exemplary)

Table 6: Legend for figure "Labeling"

Position	Description
30	Manufacturer's mailing address
31	Connection assignment of S-BUS
32	Connection assignment of outputs
33	Connection example
34	Connection assignment of supply input
35	Information on approvals and CE marks
36	Unambiguous identification of module
37	Item number

On the side of the module is a label, with information that would prove useful in the case of a complaint:

- BA: Work order number (40)
- SN: Serial number (40)
- Manufacturing number (41)

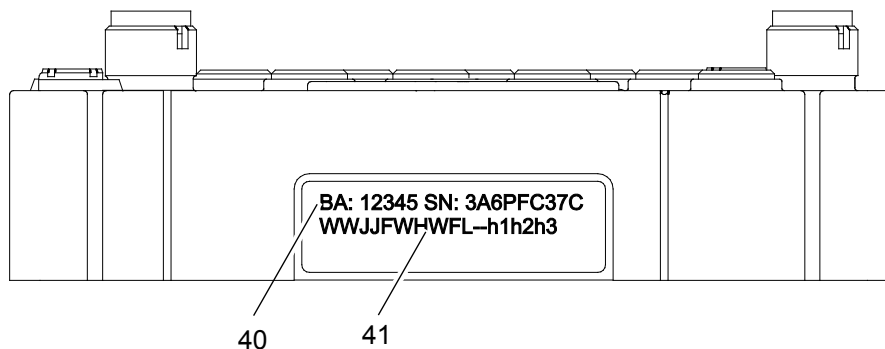

Figure 5: Label on the module

Table 7: Description of manufacturing number

Abbreviation	Description
WW	Week of production
JJ	Year of production
FW	Firmware release index When updating the firmware, please note that, the firmware release index may not be conformed to the printed firmware release index on the side of the fieldbus coupler. The “Electronic Type Label” (see section “Electronic Type Label”) shows the actual firmware release index.
HW	Hardware release index
FL	Firmware loader release index
h1h2h3	Internal manufacturer information

3.5 Schematic Diagram

The following schematic diagram provides an overview of the power supply and principle of operation of the power supply connections, as well as the digital outputs of the modules (see also chapters "Connecting the Supply Cable" and "Connecting the Actuator Cable").

Please note that the common power supply of the actuators is distributed to all module connections (Pin 1 each).

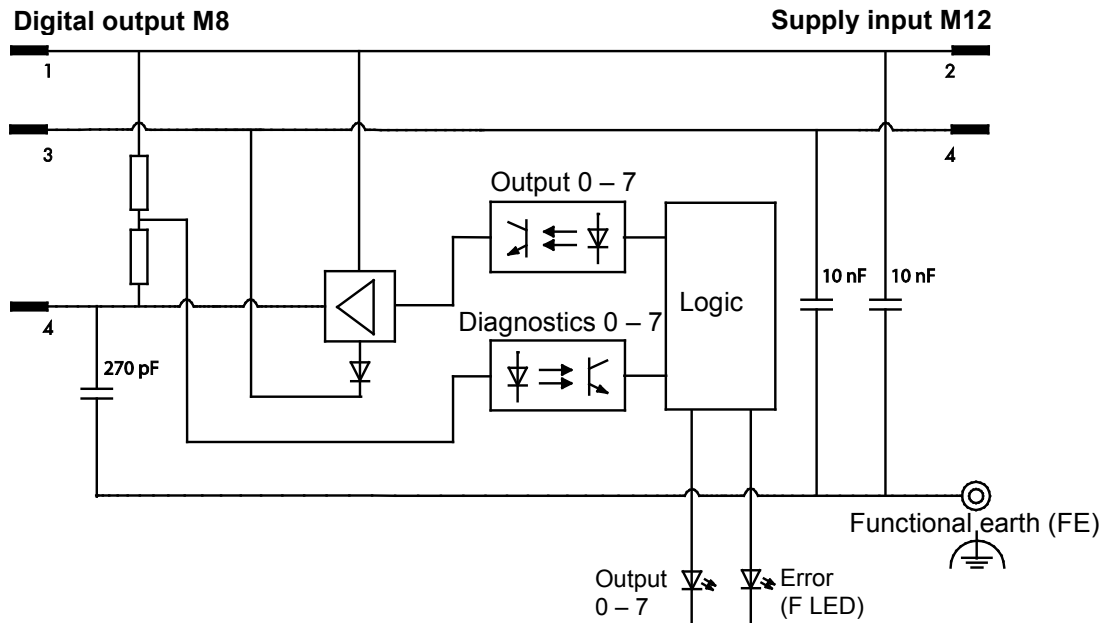

Figure 6: Schematic diagram

3.6 Dimensions

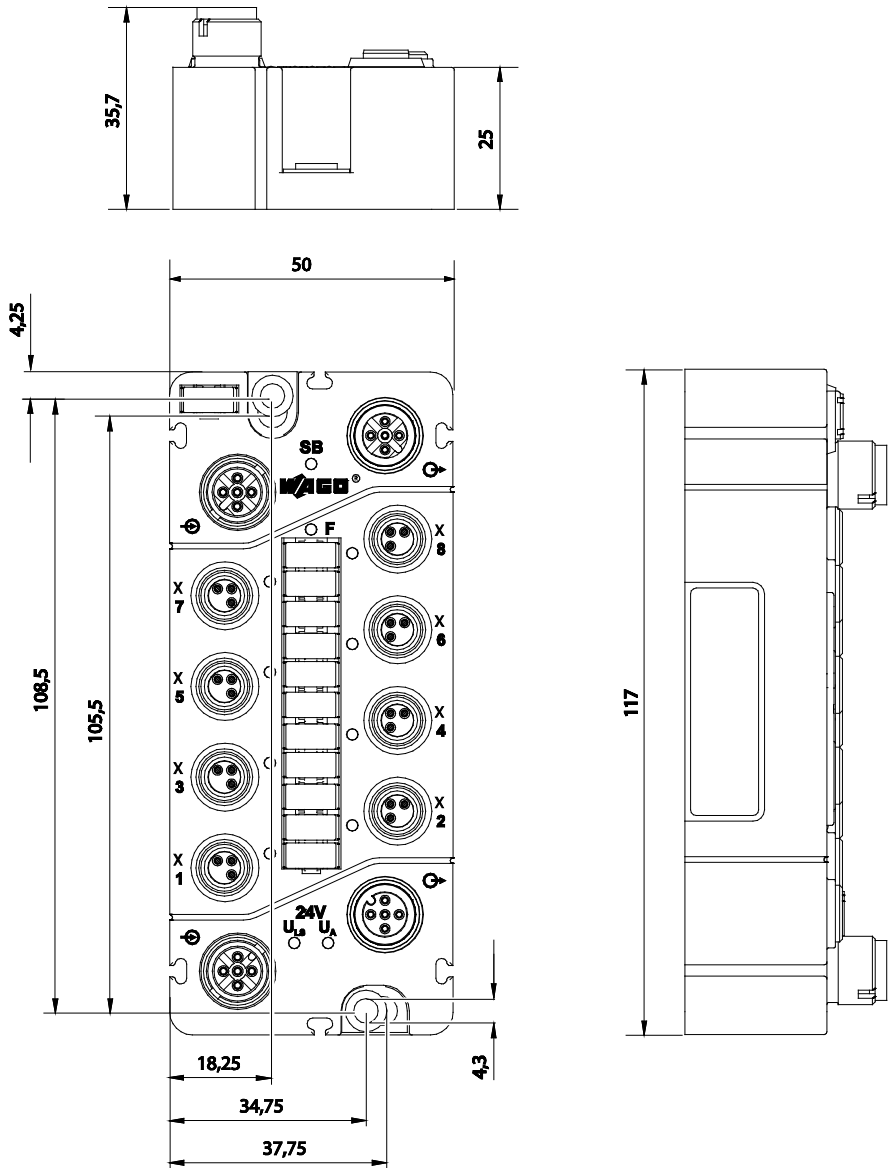

Figure 7: Dimensions of the module in millimeters (exemplary)

3.7 Technical Data



Note

Different technical data for applications in hazardous areas!

If the device is used in an application in the hazardous area, the technical data contained in the ATEX/IECEX certificate are binding in this application!

3.7.1 General Information

Table 8: Technical Data – General Information

Width	50 mm
Height	35.7 mm
Lowness	117 mm
Weight	Approx. 277 g

3.7.2 Supply

Table 9: Technical data – Supply

Connection type	M12 connectors, A-coded, 4 poles*
Current carrying capacity of the supply connections	Maximum 8 A (U_{LS} : 4 A, U_A : 4 A)
Supply voltage Logic and sensor voltage U_{LS} Actuator voltage U_A	DC 24 V (-25 % ... +30 %) DC 24 V (-25 % ... +30 %)
Supply current Logic and sensor current I_{LS} Actuator current I_A	Typically 45 mA (only logic part) Typically 55 mA + actuator
Protection	Reverse voltage protection for $U_{LS} + U_A$

* Derating must be observed.

3.7.3 Communication

Table 10: Technical data – Communication

S-BUS connection	Shielded M12 connector, B-coded, 5 poles
------------------	--

3.7.4 Outputs

Table 11: Technical data – Outputs

Number of outputs	8
Connection type	M8 connectors, 3 poles
Wire connection	2- to 3-wire
Output voltage	$\leq U_A$
Output current (per channel)	2.0 A (max. 2.4 A), short circuit/overload proof (thermal disconnection)
Voltage drop against U_A at 2.0 A	Maximum 0.2 V DC
Output current (module)	Maximum 8 A
Leakage current in OFF state	Typically 780 μ A
Output circuit	High-side switching

3.7.5 Information on Selecting the Actuator

Table 12: Technical data – Information on Selecting the Actuator

Delay time HW from 0 to 1 (0 – 90 %) from 1 to 0 (0 – 90 %)	Typically 75 μ s (resistive load) Typically 265 μ s (resistive load)
Rise time from 0 to 1	Typically 30 μ s (resistive load)
Fall time from 1 to 0	Typically 50 μ s (resistive load)
Cable length, unshielded	\leq 30 m
Protection against reverse voltages	\leq 2 A
Type of load	Inductive, resistive loads and lamps
Switching frequency	Inductive load, approx. 20 Hz Resistive load, approx. 500 Hz Lamp load, approx. 500 Hz
Recommended minimum load	50 mA*
Parallel connection of 2 outputs	For power boost For redundant actuation of a load
Type of protective circuit	External protection (e.g., recovery diodes)
Output resistance	Maximum 0.1 Ω

* Wrong diagnostics may occur at high switching frequencies with reduced load.

3.7.6 Influence of Operating States on Output

Table 13: Technical data – Influence of Operating States on Output

CPU stop of PLC	Acc. to substitute value strategy
Break of field bus	Acc. to substitute value strategy
Break of S-BUS	0 V status
Supply voltage under rated voltage tolerance	0 V status
Interruption of supply voltage	0 V status
Output operation	Non-latching
Overload behavior	Automatic restart

3.7.7 Configurable Functions

Table 14: Technical data – Configurable Functions

Inversion (per channel)	On/off
Substitute value strategy (per channel)	Switch substitute value/hold last value
Substitute value (per channel)	0/1
Manual mode (per channel)	On/off
Manual mode value (per channel)	0/1
Online simulation per channel per channel/per module	Lock/unlock; simulation value: 0/1 Diagnostics

3.7.8 Diagnostics

Table 15: Technical data – Diagnostics

Per channel	Actuator short circuit/overload
Per channel	Interruption (Wire break) Actuator
Per channel	Overtemperature
Per module	Undervoltage ($U_{LS} + U_A$)

3.7.9 Process Image

Table 16: Technical data – Process Image

Process data width	1-byte data + status
--------------------	----------------------

3.7.10 Display Elements

Table 17: Technical data – Display Elements

SB: S-BUS status	LED (green/red/orange)
F: Error status	LED (red)
0 ... 7 : Output signal status	LED (yellow)
0 ... 7 : Diagnosis of Outputs	LED (red)
$U_{LS} + U_A$: Supply status	LED (green)
Indicators	Non-retentive

3.7.11 Isolation

Table 18: Technical data – Isolation

Channel - Channel	No
U_{LS} , U_A , S-BUS	500 V DC each

3.8 Approvals

The following approvals have been granted to 767-4803/000-800 module:

 Conformity Marking

 cUL_{us} UL508

The following Ex approvals are pending for 767-4803/000-800 module:



BVS 15 ATEX E098X

II 3 G Ex nA IIC T5 Gc

II 3 D Ex tc IIIB T90°C Dc

IECEX BVS 15.0083X

Ex nA IIC T5 Gc

Ex tc IIIB T90°C Dc

3.9 Standards and Guidelines

The module 767-4803/000-800 meets the following standards and guidelines:

EC EMC Directive	2004/108/EC
EMC CE-Immunity to interference	acc. to EN 61000-6-2
EMC CE-Emission of interference	acc. to EN 61000-6-4
Ex Directive	94/9/EC
Explosive atmosphere Devices – General requirements	EN 60079-0
Explosive atmosphere Equipment protection by type of protection "n"	EN 60079-15
Explosive atmosphere Equipment dust ignition protection by enclosure "t"	EN 60079-31
Explosive atmospheres General requirements	IEC 60079-0
Explosive atmospheres Equipment protection by type of protection "n"	IEC 60079-15
Explosive atmospheres Equipment dust ignition protection by enclosure "t"	IEC 60079-31

4 Mounting

The module can be fastened directly to your system using screws. It can also be mounted on a carrier rail using an adapter or fastened to a profile rail using a surface mounting profile.

For mounting on a flat surface, WAGO offers spacers to assist in the mounting process that can be inserted between the 767 Series components. This helps by providing sufficient mounting distance for compact direct mounting, as well as eliminating gaps where dirt could accumulate. A cable tie can be fastened through each of two mounts in the spacer, which together serve to relieve strain from the sensor or actuator cables.

4.1 Information on Mounting

The following information shall always be observed:

- Disconnect the power supply from the system before you start with installation.
- The maximum diameter of the drill hole of the module's mounting holes is not to exceed 4 mm. Otherwise, a full contact with function earth (FE) socket of the module not be guaranteed. This may lead to restrictions in the shielding.
- To protect the module from tensile forces that may arise, do not bridge spaces with it.
- Screw the module down only on flat contact surfaces to protect it from warping.
- Ensure that the connectors are not soiled during installation. Dirt and other such substances damage the contacts, allowing corrosion to develop.
- To avoid damaging the module, do not mount it in shear areas of moving devices.
- Arrange for a sufficient potential equalization in your system.
- Use all mounting holes to mount the module to your system so all FE (function earth) connections lie on a ground potential.

Any mounting position is possible.

Note



Ensure a safe mounting position!

In explosion hazardous environments no increased mechanical loads must be present at the installation location. If shocks are possible, a shock protection must be installed between the module and the possible source of the shock.

4.2 Tools and Accessories Required for Mounting

Depending on the mounting type, the following tools are required for installation:

- A screwdriver for M4 fixing screws
- Drilling machine to pre-drill the mounting holes for the module to be mounted to the system and, if applicable, for the imperforated carrier rail.
- M4 thread cutter (bottoming tap or hand tap set)

The WAGO accessories listed below are required for mounting. The associated item numbers can also be found in the 767 Series fieldbus manuals, in the "Accessories" section. Select the manual appropriate to the fieldbus you are using.

- Carrier rail adapter, including fixing screws and perforated or imperforated carrier rails (DIN rail 35 x 7.5 or DIN rail 35 x 15) according to EN 60715, also available from WAGO.

or

- Profile adapter, including fixing screws
- Spacer (optional)

Two M4x12 screws are required for direct mounting of the module. The length of the screw shaft is to be selected according to the mounting type.

Bore measurements

When fastening the 767 Series components without a threaded hole, the clearance hole must not be wider than 4 mm so as to ensure safe contact of the FG (functional ground) connections.

4.3 Direct Mounting on Your System

Mount the module directly on a level surface of your system, without using WAGO accessories. Direct mounting of the module is to be carried out as follows:

1. Disconnect the power supply from those devices on which you wish to mount the module.
2. Mark the drill holes using the hole drilling template printed on the packaging. You can also hold the module in the desired position and mark the drill holes. Ensure that there is sufficient space around the 767 Series components to enable you to connect all cable without problems.

Note



Direct Mounting

We recommend using WAGO spacers for compact direct mounting. If these are used, the resulting additional distance from the second 767 Series component is to be noted. See section “Mounting the Module” > “Mounting the Spacer in the Case of Compact Arrangement”.

3. Fasten the module with two M4x12 screws via the two mounting holes.

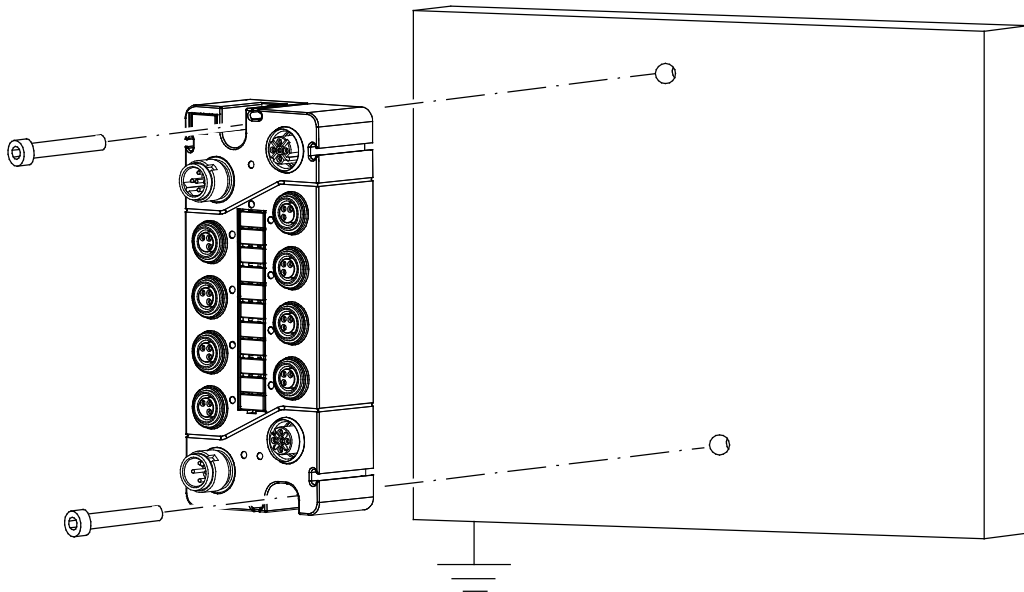

Figure 8: Mounting the module on the grounded system

4.4 Mounting on a Carrier Rail (only with WAGO Accessories)

4.4.1 Fastening the Carrier Rail Adapter to the Module

A carrier rail adapter is required to mount the module on carrier rails.

Screw together the module and carrier rail adapter using the M4 threaded screws provided, as shown in the figure below.

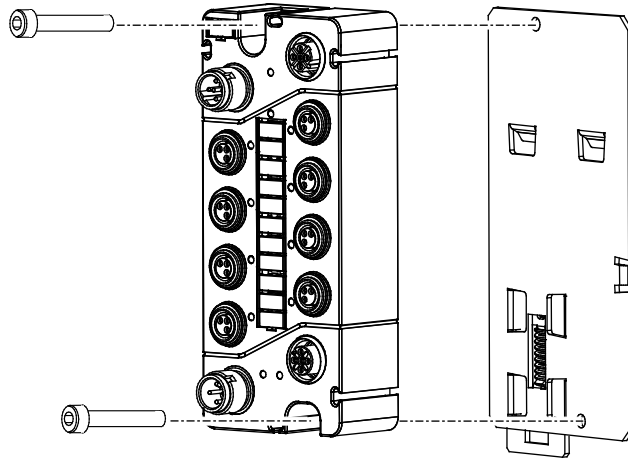

Figure 9: Fastening to the carrier rail adapter

4.4.2 Fastening the Module with Carrier Rail Adapter to a Carrier Rail

In order to provide a clear representation, the carrier rail adapter in the figure below is shown without module.

When mounting the module to a carrier rail (DIN rail 35 x 7.5) using a carrier rail adapter, proceed as follows:

1. Disconnect the power supply from those devices on which you wish to mount the module.
2. Set the module onto the edge of the carrier rail (51) with the two notches (50).
3. Press the undersurface against the lower carrier rail edge until the latch (52) locks in place.

Note



Use end stops

When mounting the rail vertically or if shock or vibration loading should occur, the use of end stops (item no.: 249-116 or 249-117) for stabilization is required.

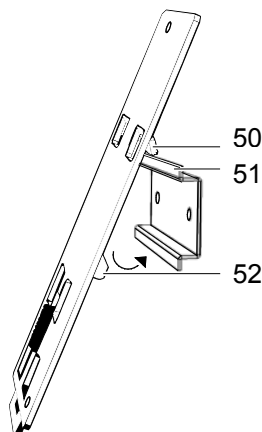

Figure 10: Mounting the carrier rail adapter (exemplary)

4.5 Mounting on a Profile Rail (only with WAGO Accessories)

4.5.1 Fastening the Profile Adapter to the Module

Aside from using carrier rail adapters to fasten the module, you also have the option to fasten it to a profile rail using the profile adapter and nuts, provided that this mounting type is supported by your system. You are to supply the necessary nuts.

Screw together the module and the profile adapter using the M4 threaded screws provided, as shown in the following figure.

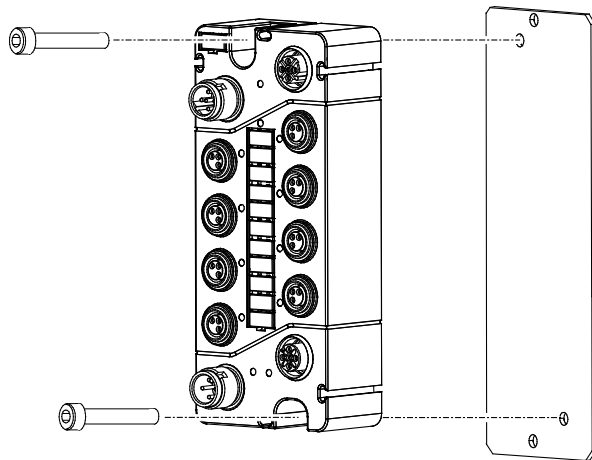

Figure 11: Fastening to the profile adapter

4.5.2 Fastening the Module with Profile Adapter to a Profile Rail

To fasten the module to a profile rail of your system, two nuts are required with one screw each (length of screw threads must be compatible with your system).

1. Disconnect the power supply from those devices on which you wish to mount the module.
2. Insert the two screws into the holes above and beneath the fastened module on the profile adapter.
3. Fasten an appropriate nut on each of these screws.
4. Insert the profile adapter with the attached module into the profile rail of your system. Position it and tighten the screws.

4.6 Marking and Replacing the Marking Spaces

The module marker card (10) and marking strip (12) are attached when delivered. The protective cover is to be removed when labeling the marking strip. To do this, proceed as follows:

1. Press the slot screwdriver (maximum slot width: 3mm) into the small opening under the marking strip cover (12) and lever it up.
2. Remove the marking strip cover.
3. Mark the marking strip with a waterproof pen.
4. Reinsert the marking strip cover and press it firmly in place.

If the module's marker card (10) must be replaced, proceed in accordance with the step sequence described previously. New module marker cards can be obtained through WAGO.

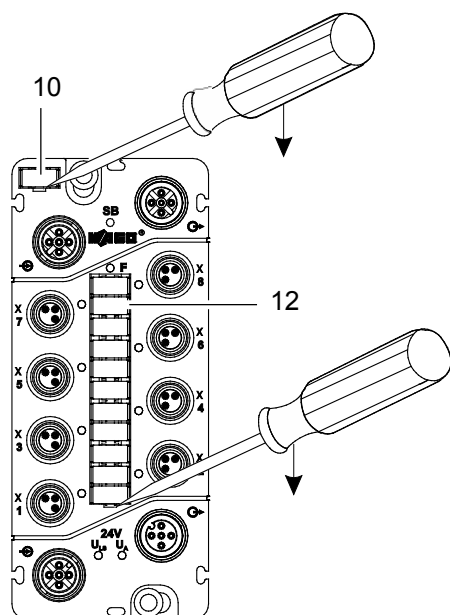

Figure 12: Replacing the marking spaces

4.7 Mounting the Spacer in the Case of Compact Arrangement

By using the spacer, a sufficient mounting distance can be achieved when directly mounting the 767 Series components, and gaps can be eliminated where otherwise dirt and other substances could accumulate. In addition, it is possible to optimize the cable routing. For this purpose, two fastening lugs each are included on the spacer for cable ties.

1. Disconnect the power supply from those devices on which you wish to mount the module.
2. The spacer can only be inserted into the appropriate openings of the module from the bottom. To bind both components, place the module on the spacer or push the spacer from the bottom into the module.
3. Fasten the attached components on a flat surface by fastening the module to the grounded frame of your system or to another grounding point with two M4 screws via the mounting holes.

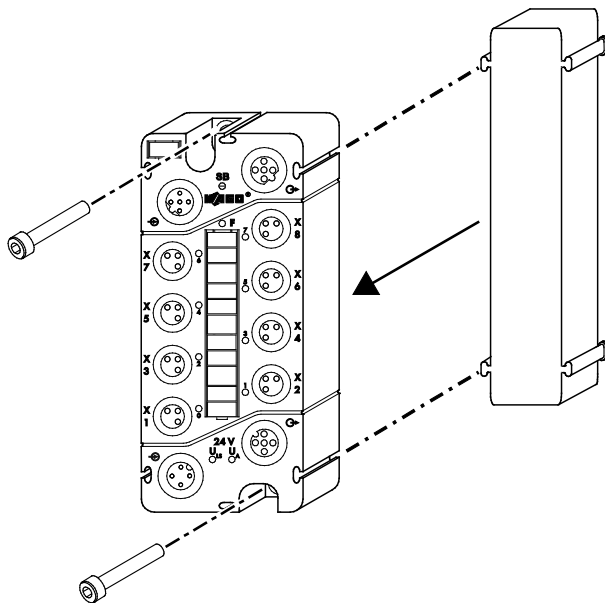

Figure 13: Attaching a spacer to a module

4. When attaching 767 Series component, only one 767 component connected with a spacer can be attached and screwed on to the preceding component due to the mounting direction. The last 767 component is fastened without a spacer.

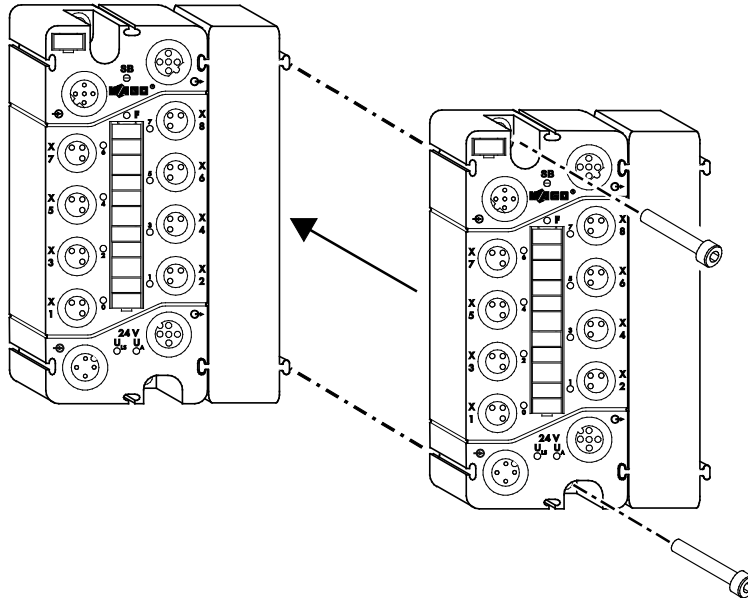

Figure 14: Attaching another module with a spacer

5 Connecting Data and Supply Cables

5.1 Notes



DANGER

Electric voltage!

Operate the 767 Series components exclusively with 24 VDC PELV (Protective Extra Low Voltage) or SELV (Safety Extra Low Voltage) voltage sources. Failure to comply may result in electric shock.

NOTICE

The highest current carrying capacity of the supply contacts is 4 A!

Always observe the maximum current carrying capacity per supply line (U_{LS} , U_A) for each 767 Series component and the overall power consumption for all 767 components. Neither of these values shall exceed 4 A since an increase in current causes the contacts to overheat and damages the 767 Series components. Information regarding the power demand of each 767 Series component can be found in the corresponding data sheet, which is available from www.wago.com.

NOTICE

Exposed connections!

If connections have not been closed with protective caps, liquid or dirt can penetrate the components of the 767 Series module and ruin it. Therefore, close all unnecessary connections with protective caps, which must be ordered separately, in order to maintain the IP67 degree of protection. (See section “Accessories” of the fieldbus coupler/controller manual.)

- The connectors must be disconnected from the power supply when screws are tightened.
- Tighten the connectors by hand. To achieve the required torque (see below) for the connector, use the torque wrench with the order number **206-701**.

Torque for M8 connectors:	0.6 Nm
Torque for M12 connectors:	1.0 Nm

NOTICE

Use torque wrench 206-701!

Only use the specified torque wrench. Using mechanical tools can cause the threads to strip.

In this case, replace the module!

- For both power supply and S-BUS, use only pre-assembled WAGO system cables so the specified characteristics of the technical data can be achieved.

- Do not use drop lines under any circumstances. This can lead to amplified line reflections and signal distortions, which greatly impair the transmission quality.
- Observe the exact positioning (coding) between plug and socket.
- Keep all cables a sufficient distance away from electromagnetic sources of interference in order to maintain a high level of interference resistance of the 767 system against electromagnetic emissions.
- Observe the minimum bending radiuses of the WAGO system cable. For more information, see the technical data at www.wago.com.
- When laying all cable, ensure that you do not lay it in shear areas of moving machine parts.
- Observe the correct layout of the potential equalization.

5.2 Required Accessories

The WAGO accessories listed below are required for connecting the data and supply cable. The associated item numbers can also be found in the fieldbus manuals for 767 Series, in the "Accessories" section. Select the manual appropriate to the 767 Series fieldbus you are using.

- S-BUS M12 terminator, IP 67
- S-BUS and supply cables, pre-assembled on both ends, IP 67
- Torque wrench
- Protective caps

5.3 Connecting the S-BUS Cables

The S-BUS is used for communication between a fieldbus coupler and the connected 767 Series components.

Requirement:

- A WAGO S-BUS cable pre-assembled on both ends is readily available to you. This is necessary for optimal signal transmission.
- The S-BUS terminator is available to you, which is necessary for communication.

The following table outlines the assignment of the S-BUS connections:

Table 19: S-BUS connection assignment

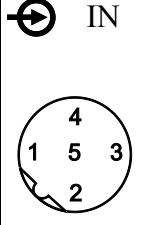
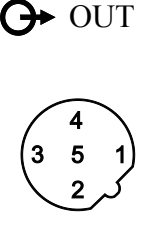
Connection		Contact	Description	
			IN	OUT
		1	RD +	TD +
		2	RD -	TD -
		3	TD -	RD -
		4	TD +	RD +
		5	GND	
		Connecting thread	Shield	

To connect the S-BUS cables to fieldbus coupler and I/O modules, proceed as follows:

1. Disconnect the power supply from those devices on which you have mounted the module.
2. Connect the S-BUS cable (S1) with the OUT connection \odot (3) of the fieldbus coupler and the IN connection \ominus (1) of the module. For example, if two I/O modules have been connected to the fieldbus coupler, connect the S-BUS cables (S1, S2) to the associated IN and OUT connections, as shown in the following figure.
3. Tighten the plugs and sockets using the knurled-head screws.
4. Attach the S-BUS terminator (T) to the last I/O module as shown in the figure and tighten it.

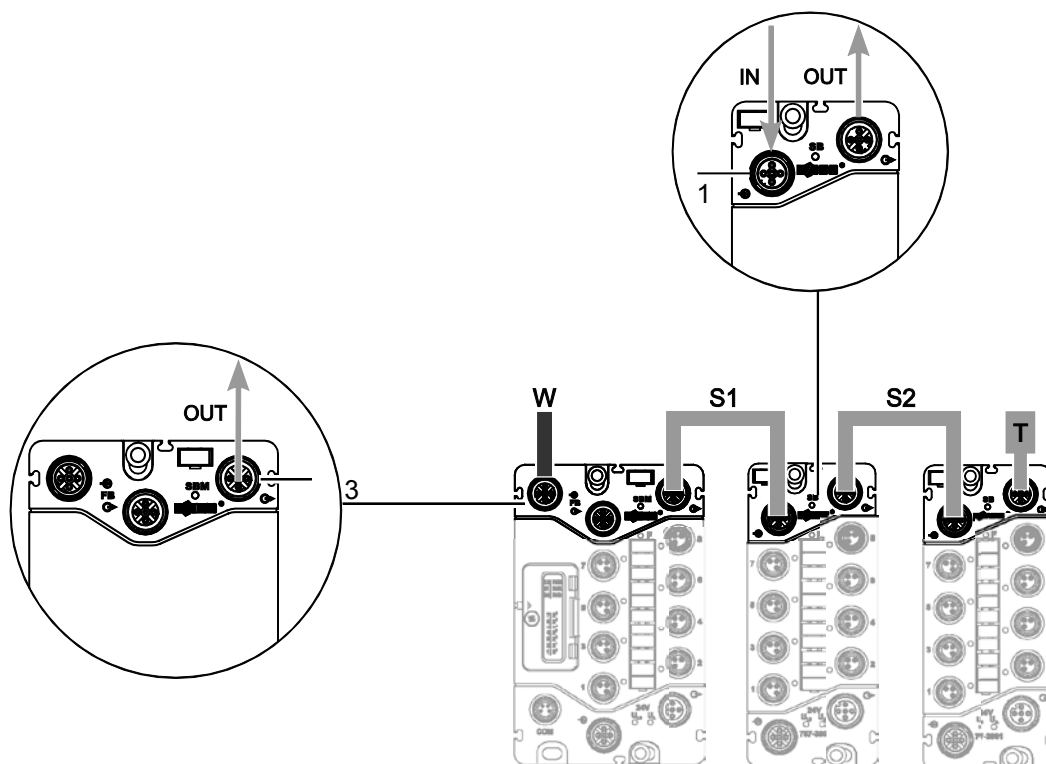

Figure 15: S-BUS connected to a fieldbus coupler and modules

5.4 Connecting the Supply Cable

The supply cable provides power to the module.



Note

Retransmission of power supply not possible!

Because of the module's increased output current of 2 A for each channel, retransmission of the power supply is not possible. It has two IN connections as a result of the increased power requirement. For subsequent modules, the power supply must therefore be newly fed.

Requirement:

The WAGO supply cables K1 and K2, which are pre-assembled on both ends, must be available (see Fig. 15). The following table outlines the assignment of the supply connections. Please note that you supply the 24 V for U_{LS} of both IN connections from one power supply and 24 V for U_A of both IN connections also from one power supply. In addition, the supply lines must have the same line resistance (same length and cross section) to achieve an equal current distribution to the supply connections.

Table 1: Supply connection assignment

Connection	Contact	Description	
	1	24 V DC U_{LS}	
	2	24 V DC U_A	
	3	0 V U_{LS}	
	4	0 V U_A	
	1	24 V DC U_{LS}	
	2	24 V DC U_A	
	3	0 V U_{LS}	
	4	0 V U_A	

NOTICE

The highest current carrying capacity of the supply contacts is 4 A!

Always observe the maximum current carrying capacity per supply line (U_{LS} , U_A) for each 767 Series component and the overall power consumption for all 767 components. Neither of these values shall exceed 4 A since an increase in current causes the contacts to overheat and damages the 767 Series components. Information regarding the power demand of each 767 Series component can be found in the corresponding data sheet, which is available from www.wago.com.

To connect the supply cable to the fieldbus coupler and I/O modules, proceed as follows:

1. Disconnect the power supply from those devices on which you have mounted the module.
2. For example, if on I/O module and this 2-A module have been connected to the fieldbus coupler, connect the power supply transmission cable (K1) to the associated IN and OUT connections, as shown in the following figure.

Note



Retransmission of power supply not possible!

Because of the 2-A module's increased output current of 2 A for each channel, retransmission of the power supply is not possible. It has two IN connections as a result of the increased power requirement. For subsequent modules, the power supply must therefore be newly fed.

3. Use the two IN connections (K2, K3) to supply power for the 2-A module, as shown in the following figure.
4. Tighten the plugs and sockets using the knurled-head screws.
5. Screw a protective cap on all unused ports to ensure that IP 67 degree of protection is provided.

Information on connecting the power supply cable (K0) to the "IN" port ⑥ (6) of a fieldbus coupler can be found in the appropriate manuals.

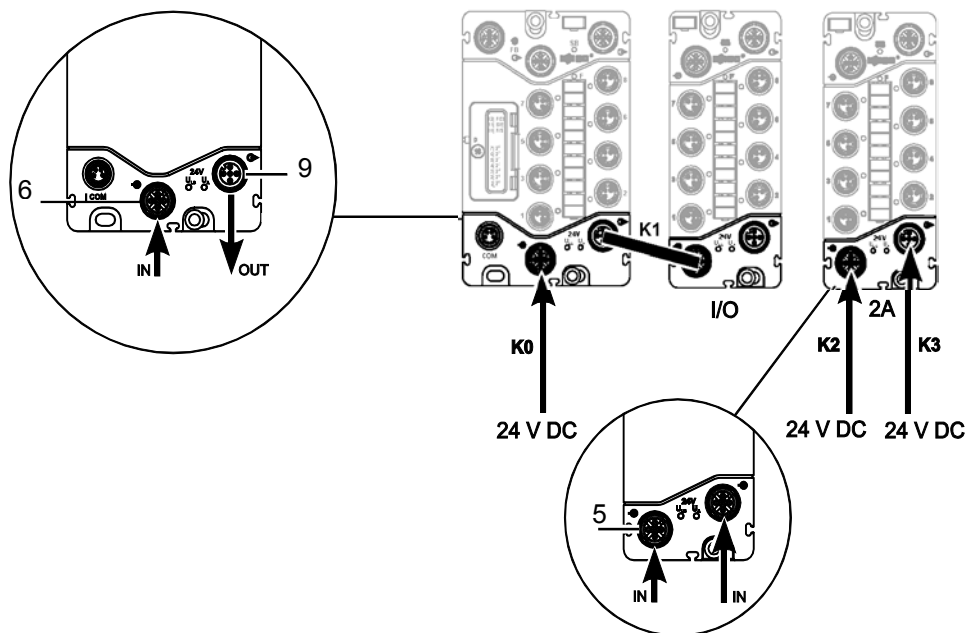

Figure 16: Supply cable connected to the fieldbus coupler, I/O module and 2-A module

5.5 Connecting the Actuator Cable

The actuator cable provides power to the connected actuators and transmit the actuator signals.

When using cables that have not been pre-assembled, make sure that these cables are equipped with M8 plugs rated to IP67. The following table outlines the assignment of the actuator connections:

Table 20: Connection assignment of digital outputs

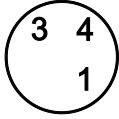
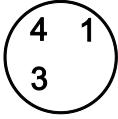
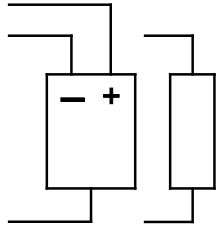
Connection		Connection diagramm
OUT  X1, X3, X5, X7	OUT  X2, X4, X6, X8	1: 24 V U _A 3: 0 V U _A  4: Output

NOTICE

The highest current carrying capacity of the supply contacts is 4 A!
 Consider that the actuators are supplied from the U_A supply line. The actuators' current consumption is to be taken into consideration when determining the present current demand for the U_A supply line.

To connect the actuators to the digital outputs, proceed as follows:

1. Disconnect the power supply from those devices on which you have mounted the module.
2. Insert the actuator cable plug into an output socket (3) of the module, and tighten it via knurled-head screw.
3. Screw a protective cap on all unused ports to ensure that IP67 degree of protection is provided.

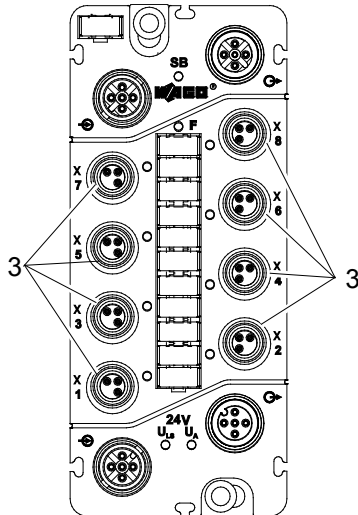

Figure 17: Connectors (exemplary)

6 Commissioning

NOTICE

Exposed connections!

If connections have not been closed with protective caps, liquid or dirt can penetrate the components of the 767 Series module and ruin it. Therefore, close all unnecessary connections with protective caps, which must be ordered separately, in order to maintain the IP67 degree of protection. (See section "Accessories" of the fieldbus coupler/controller manual.)

Before starting up the 767 node, ensure that the following requirements are met:

- Both 767 Series Fieldbus Coupler and Module 767-4803/000-800 have been properly mounted (See also fieldbus coupler manuals Series 767).
- The fieldbus, all necessary supply and sensor lines, and the S-BUS bus terminator are all securely fastened onto the appropriate connections (see section "Connecting Data and Supply Cables").
- An appropriate potential equalization is implemented in your system.
- Shielding is carried out properly.

7 Parameterizing

All parameters listed here can be set using WAGOframe (or another FDT/DTM frame application) for the module.

If you use a fieldbus for the parameterization, only certain parameters are configurable, depending on the type of fieldbus.

DANGER

Changing parameters!

When parameters are incorrectly modified via FDT/DTM frame application (e.g., WAGOframe), machine components could be placed in a dangerous state and personnel and machines could be at risk.

Before changing the parameters, ensure that the machine components are in a safe and defined state and switch off the higher-level controller.

Also ensure before start-up that no personnel remain in the danger area of the machine components.

For the parameterization of the module, an appropriate DTM is available. Via this DTM, you can parameterize the module either online or offline. The offline mode enables the parameterization of a module that is not yet present. In the offline mode, first store the parameters in a project and later transfer them to the module.

In the online mode there is a direct link between the display and the connected module. If the module is in the online mode, its name is displayed in **bold** and *italic* font in the network window.

Note



Detailed informations.



Detailed information on handling WAGOframe can be found in the fieldbus coupler manuals.

The following sections provide information on the parameters and their descriptions.

To open the parameterization user interface (DTM) of the module, double-click on the module in the "Network View" of WAGOframe. The parameterization user interface can also be opened by right-clicking on **Offline Parameter** or **Online Parameter** in the context menu.

If several DTMs are open, select one via the corresponding tabs. Depending on the DTM you have selected, different buttons are provided:

Table 21: DTM buttons

Buttons	Description
[Read] (Online mode only)	Reads and displays the parameters found in the module.
[Write] (Online mode only)	Writes the modified values to the module.
[Close] (Online and offline mode)	Closes the parameterization user interface (DTM).
[Apply] (Offline mode only)	Applies the entries in the project. Please note that the project should also be subsequently saved (File > Save).
[Help] (Online and offline mode)	Opens the online help for an entry that has been previously selected in the DTM (e.g., digital inputs, global setting).
	Shows/hides parameter overview.
	Displays the product data sheet. A PDF reader must be installed on your PC.
	Opens the DTM online help.

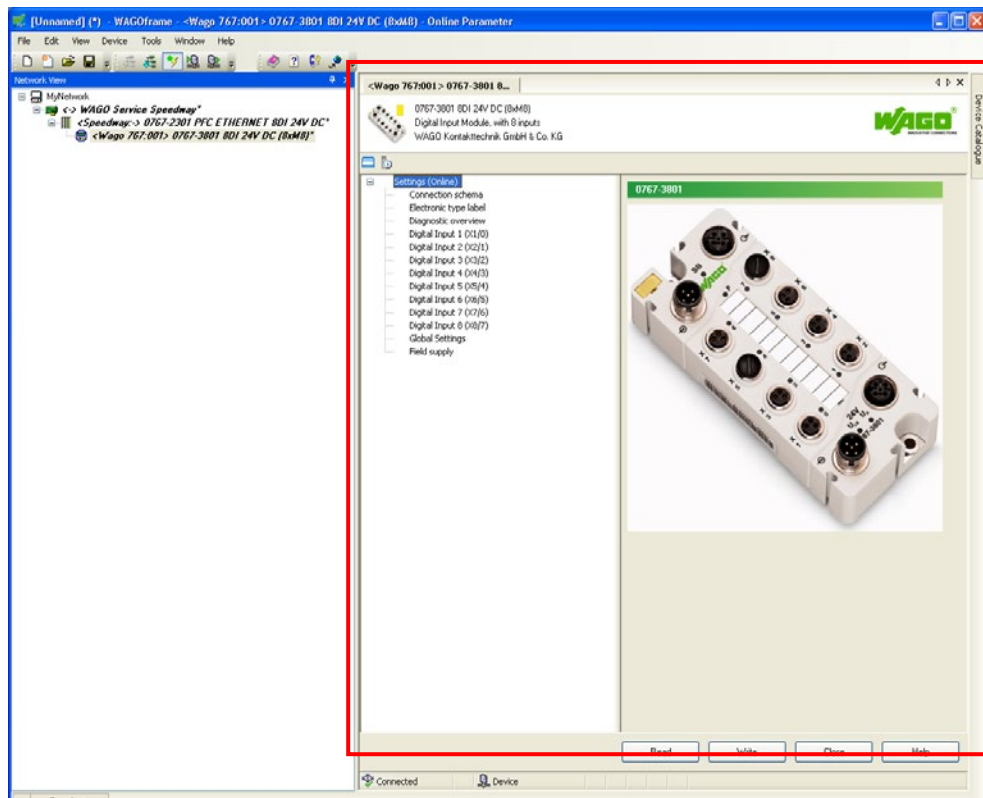

Figure 18: Example of an open DTM, including parameters

7.1 Electronic Type Label

Table 22: Information on the module

Parameter	Description
Vendor	Manufacturer
Release index	FW.HW.FL FW: Actual firmware release index. When updating the firmware, please note that the firmware release index may not be conformed to the printed firmware release index on the side of the fieldbus coupler. HW: Hardware release index FL: Firmware loader release index
Firmware revision	General information on the module
Order number	
Description	
Serial number	
Date of production	
Designation	Electronic marking field

7.2 Diagnostic Overview

The currently pending diagnostics existing on the module are displayed here. In this view of the DTM, you can enable simulation of the diagnostics, as well as disable transmission of the diagnostics. When disabling transmission, make sure that the display behavior of each LED changes that indicates the specific diagnostics (section "Diagnostics" > "LED Signaling"). The diagnostic overview is only available in online mode.

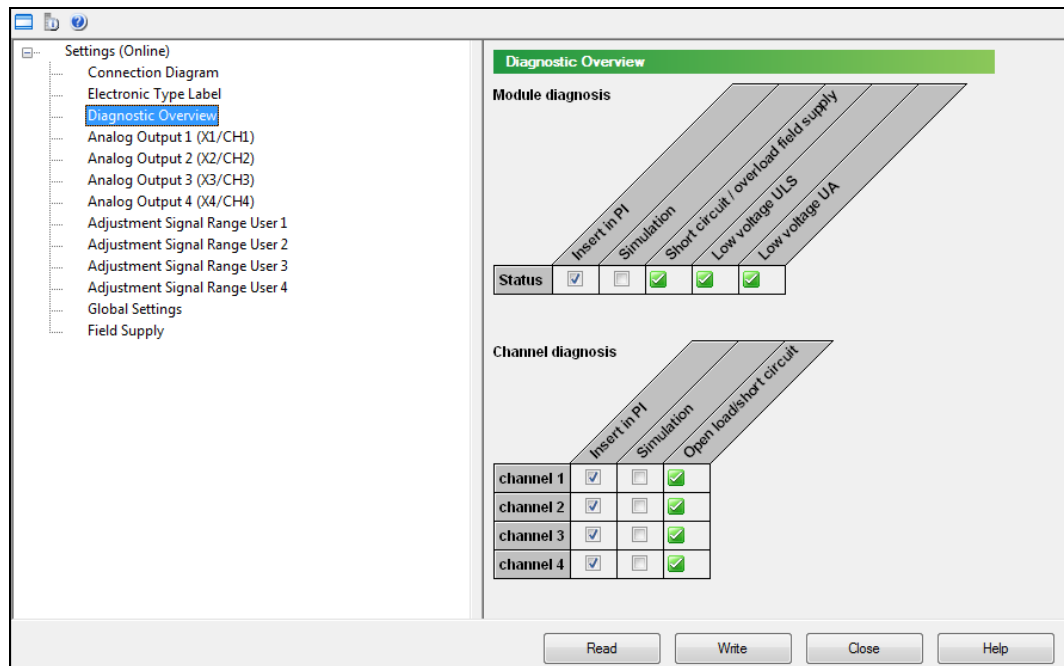

Figure 19: Example of the diagnostic overview of a module (information may differ from the actual module)

Table 23: Diagnostics setup

Parameter	Description
Insert in PI	By unselecting the checkbox, you specifically suppress evaluation and transmission of individual diagnostics. Doing so has no effect on the size of the process image. Even if a diagnostics has occurred, the diagnostic value "0" (no error) is transmitted to the higher-level controller.
Simulation	If you have selected the "Insert in PI" checkbox, the "Simulation" parameter is released. You can select the diagnostics you want to simulate. Click the [Write] button to transfer the simulated values to the module.
Status	Displays whether there is a diagnostics: X mark: There is a diagnostic message. Check mark: There is no diagnostic message.

Table 24: Information about existing module diagnostics

Global Diagnostics	
Diagnostics	Description
Low voltage of U_{LS}	<p>⚠ WARNING</p> <p>Disabling the outputs. If there is an undervoltage of U_A and/or U_{LS}, the module outputs are disabled. Machine components can be placed in a dangerous condition, as well as personnel and machine put in danger.</p> <hr/> <p>If an undervoltage of the logic and sensor supply U_{LS} of $< 18\text{ V}$ occurs on the module, the outputs are disabled and a corresponding diagnostic is transmitted to the fieldbus coupler. The F-LED of the module illuminates.</p>
Low voltage of U_{LS}	<p>⚠ WARNING</p> <p>Disabling the outputs. If there is an undervoltage of U_A and/or U_{LS}, the module outputs are disabled. Machine components can be placed in a dangerous condition, as well as personnel and machine put in danger.</p> <hr/> <p>If an undervoltage of the actuator supply U_A of $< 18\text{ V}$ occurs on the module, the outputs are disabled and a corresponding diagnostic transmitted to the fieldbus coupler. The module F-LED illuminates.</p>

Table 25: Information about an existing channel diagnostic

Channel Diagnostics	
Diagnostics	Description
Actuator short circuit/overload	The module has identified a short circuit or overload on the corresponding channel (1 ... 8) (only enabled when the actuator output is switched on).
Actuator open load	The module has identified a disruption on the corresponding channel (1 ... 8) only enabled when the actuator output is switched off).
Overtemperature	The module has identified overheating on the corresponding channel (1 ... 8) (only enabled when the actuator output is switched on).

Note



Interruption of the S-BUS

If there is an interruption of the S-BUS, the module is automatically put in STOP mode. The module outputs are disabled.

7.3 Parameters of Outputs

WARNING

Manually-set outputs in manual operation mode!

In manual operation mode (setup mode), software protection mechanisms do not monitor the motion of individual machine components.

The outputs in manual operation mode that were set with WAGOframe remain active until you manually reset them or restart the fieldbus coupler. The protective shutdown of software proves ineffective in this case.

In manual operation mode, personnel are not allowed to stay in the danger area of the machine components.

Table 26: Overview of adjustable parameters for the digital outputs

Parameter	Description
Designation	Electronic marking field (max. 40 characters)
Output value	This value is released to the outputs. <i>Default setting: 0</i>
Process image value	This value is released from the process image to the outputs, taking into account inversion. If manual operation is activated, a value entered here is released to the outputs instead of the process value. Checkbox unselected: 0 Checkbox selected: 1
Signal inverting	Here you can release the currently pending process value as an inverted output value. Checkbox unselected: Output signal is released as indicated in process image Checkbox selected: Output signal is released in an inverted manner, as indicated in process image
Substitute Value Strategy	This releases the substitute value or the last output value in cases such as a fieldbus interruption. You have the following options: - Switch to substitute value* - Retain last value**
Substitute Value	Enter here the process value that is released in case of an error or if a fieldbus is missing. In the case of an error (fieldbus interruption), this value is used with the "Switch to Substitute Value" substitute value strategy. Checkbox unselected: 0* Checkbox selected: 1

Table 26: Overview of adjustable parameters for the digital outputs

Parameter	Description
Manual operation	<p>Manual operation enables you to set the outputs irrespective of the process data. The checkbox of the "Process Image Value" parameter is unselected. Here you can enter the desired process value.</p> <p>Checkbox unselected: Process data is released = 0</p> <p>Checkbox selected: Entered process value is released = 1</p>
Simulation diagnostics	<p>If this parameter is activated, you can simulate the channel-specific diagnostics.</p>
Restart mode, actuator	<p>Set the start behavior of the output that was disabled based on the "Short circuit/overload actuator" and/or "Overtemperature" diagnostics.</p> <p>Checkbox unselected (0)*: After the "Restart delay, actuator time" has elapsed, the output is switched on again automatically..</p> <p>Checkbox selected (1): The output is only switched on again after you confirm the diagnostic message.</p>
Restart delay, actuator	<p>Time in 100 ms intervals, after which a disabled output is switched on again in case of error.</p> <p>You must unselect the checkbox under "Restart mode, actuator" (0). <i>Default setting: 10 * 100 ms = 1000 ms</i></p> <p>Note If you set the time of the "Restart delay, actuator" parameter to 0 ms, the I/O LED appears yellow instead of red if a short circuit or overload appears due to the short restart interval (see Section "Diagnostics" > "LED Signaling").</p>
Short circuit/overload, actuator	<p>If "Simulation Diagnostics" is disabled, the corresponding error is displayed upon occurrence (default setting).</p>
Disruption Actuator	<p>If "Simulation Diagnostics" is enabled, you can simulate one of the errors by selecting the appropriate parameter.</p>
Overtemperature	

* Default setting

** The last value is the value output to the contact before occurrence of the respective interruption. This can be, for example, a process value or manual operation value.

7.4 Global Settings

Table 27: Overview of parameters for the entire module

Parameter	Description
Simulation diagnostic	If the checkbox is selected, you can simulate a low voltage diagnostic. To generate a low voltage diagnostic, one or both of the two checkboxes "Low voltage U_{LS} " and "Low voltage U_A " must be selected. <i>Default setting: unselected</i>
Low voltage U_{LS}	In the case of an undervoltage of the logic and sensor supply (U_{LS}) or the actuator supply (U_A), the corresponding diagnostic is displayed here.
Low voltage U_A	

7.5 Automatic Storage of System Parameters

Some fieldbus couplers provide the "System Parameter Handling" feature. This serves to identify changes to the configuration of a 767 Series node and to the automatic configuration of the I/O modules. When an I/O module must be replaced due to a defect, you do not need to reconfigure the new I/O module. The stored parameters are automatically transferred to the new I/O module. Detailed information on this procedure can be found in the fieldbus coupler manuals in the "Parameter Setting via FDT/DTM" section.

7.6 Updating the Firmware

When updating the module firmware, the saved module parameters can be overwritten. Therefore, check your existing configuration after updating the firmware.

8 Process Image

The process images for the module listed in the following sections describe the data length on the S-BUS (system bus). The implementation of the S-BUS process images onto the respective fieldbus process images can be found in the fieldbus coupler manuals.

The process image is divided into two areas: an output data area and an input data area. The process image can contain process data with and without diagnostic information, independently of whether the transmission of synchronous diagnostic information has been selected.

Note



Synchronous diagnostic information

Synchronous diagnostic information designates the cyclical transmission of diagnostic information in the process image. This is not selected in the original factory settings for the module.

This is only possible when using a fieldbus coupler that supports the synchronous diagnostic function (e.g. 767-1101 or 767-2301). Detailed information about enabling the transmission of diagnostic information can be found in the manual for the fieldbus coupler being used: see the section about the device description file.

In addition, you can also switch on synchronous diagnostic information in fieldbus couplers that support this function by using an FDT/DTM frame application (e.g. WAGOframe) in the corresponding DTM. For more information, see the Section "Parameterization via FDT/DTM" > "Diagnostics setting" in the fieldbus coupler manuals.

Note



Activate module diagnostics

You can enable or suppress the individual module diagnostics. For more information, see the Section "Diagnostics Overview".

Note



Diagnostics "Actuator short circuit/overload", "Over temperature" and "Actuator Supply Open Load"

The diagnostics of the outputs for "Actuator short circuit/overload", "Over temperature" and "Actuator Supply Open Load (Wire break)" are dependent on the switching status of the outputs. If the output is switched on, any short circuit, overload or over temperature that occurs can be diagnosed. If the output is switched off, only an open load detection can be diagnosed.

8.1 Output Data

The process image for the output data that is transmitted from the fieldbus coupler to the I/O module has a size of 1 byte. If you configure a synchronous diagnostic confirmation of the I/O module, the process image has a size of 5 bytes.

The diagnostic confirmation is structured as follows:

Table 28: Output data in the process image

Byte 0	7	0	Digital outputs (process data)
 1 _B : Output value = True			
Byte 1	7	0	Diagnostic confirmation
 1 _B : Actuator short circuit/overload on channel 1 confirmed 1 _B : Actuator short circuit/overload on channel 2 confirmed 1 _B : Actuator short circuit/overload on channel 3 confirmed 1 _B : Actuator short circuit/overload on channel 4 conf. 1 _B : Actuator short circuit/overload on channel 5 confirmed 1 _B : Actuator short circuit/overload on channel 6 confirmed 1 _B : Actuator short circuit/overload on channel 7 confirmed 1 _B : Actuator short circuit/overload on channel 8 confirmed			
Byte 2	7	0	Diagnostic confirmation
 1 _B : Actuator supply open load on channel 1 confirmed 1 _B : Actuator supply open load on channel 2 confirmed 1 _B : Actuator supply open load on channel 3 conf. 1 _B : Actuator supply open load on channel 4 conf. 1 _B : Actuator supply open load on channel 5 confirmed 1 _B : Actuator supply open load on channel 6 confirmed 1 _B : Actuator supply open load on channel 7 confirmed 1 _B : Actuator supply open load on channel 8 confirmed			

Byte 3	7	0	Diagnostic confirmation
<p> 1_B: Overtemperature on channel 1 conf. 1_B: Overtemperature on channel 2 conf. 1_B: Overtemperature on channel 3 confirmed 1_B: Overtemperature on channel 4 confirmed 1_B: Overtemperature on channel 5 confirmed 1_B: Overtemperature on channel 6 confirmed 1_B: Overtemperature on channel 7 confirmed 1_B: Overtemperature on channel 8 confirmed </p>			
Byte 4	7	0	Diagnostic confirmation
<p> 1_B: Undervoltage U_{LS} confirmed 1_B: Undervoltage U_A confirmed </p>			

8.2 Input Data

The image for the process data, which are sent from the I/O module to the fieldbus coupler, has a size of 0 byte. If you configure synchronous diagnostic data for the I/O module, the process image has a size of 4 bytes.

The diagnostic message is structured as follows:

Table 29: Input data in the process image

Byte 0	7 0								Diagnostic message
									1 _B : Actuator short circuit/overload on channel 1
									1 _B : Actuator short circuit/overload on channel 2
									1 _B : Actuator short circuit/overload on channel 3
									1 _B : Actuator short circuit/overload on channel 4
									1 _B : Actuator short circuit/overload on channel 5
									1 _B : Actuator short circuit/overload on channel 6
									1 _B : Actuator short circuit/overload on channel 7
									1 _B : Actuator short circuit/overload on channel 8
Byte 1	7 0								Diagnostic message
									1 _B : Actuator supply open load on channel 1
									1 _B : Actuator supply open load on channel 2
									1 _B : Actuator supply open load on channel 3
									1 _B : Actuator supply open load on channel 4
									1 _B : Actuator supply open load on channel 5
									1 _B : Actuator supply open load on channel 6
									1 _B : Actuator supply open load on channel 7
									1 _B : Actuator supply open load on channel 8
Byte 2	7 0								Diagnostic message
									1 _B : Overtemperature on channel 1
									1 _B : Overtemperature on channel 2
									1 _B : Overtemperature on channel 3
									1 _B : Overtemperature on channel 4
									1 _B : Overtemperature on channel 5
									1 _B : Overtemperature on channel 6
									1 _B : Overtemperature on channel 7
									1 _B : Overtemperature on channel 8

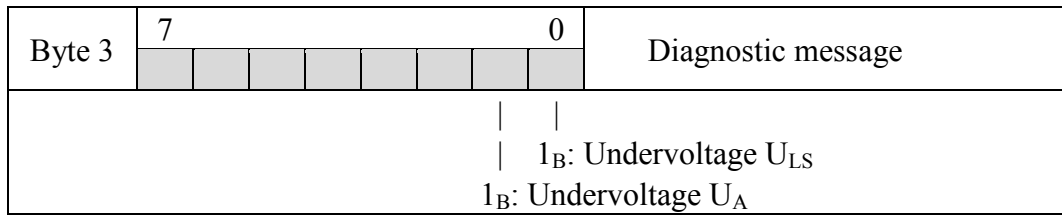

Note



Diagnostic messages

Normally, both "Actuator short circuit" and "Overtemperature" diagnostic messages are issued simultaneously!

9 Diagnostics

9.1 LED Signaling

The following table lists the operating messages that are indicated via LEDs. Information regarding remedies of certain causes is also provided.

Note



Disabling specific diagnostics

Use the diagnostic overview (section "Parameterizing" > "Diagnostic Overview") to disable specific diagnostics (see F- and I/O-LED). In this case, the corresponding LED is disabled (off).

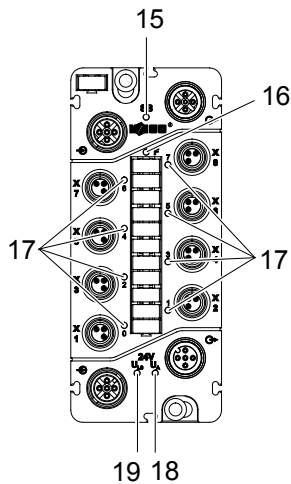

Figure 20: LEDs indicating operational messages (exemplary)

Table 30: Operating messages 1

Pos.	LED	Color/Status	Cause	Remedy/information
15	SB	Off	Low voltage; U_{LS} not available.	Check the power supply.
		Red, flashing, 4 Hz	S-BUS error on module.	Check whether the S-BUS cable is connected. Check the S-BUS cable for damages. Check whether the fieldbus coupler firmware is compatible with the module.
		Red, flashing, 1 or 2 Hz	The module is being restarted via the fieldbus coupler.	If the flashing frequency is 1Hz, please contact WAGO Support.
		Green	Data exchange is in process; process data values are valid. The module is in RUN mode.	-

Table 30: Operating messages 1

Pos.	LED	Color/Status	Cause	Remedy/information
15	SB	Green and orange, flashing, 1 Hz	The set substitute value is applied to the module.	Can be set by the fieldbus coupler if fieldbus is missing. Check the fieldbus connection and the status of the higher-level controller.
		Orange, flashing, 2 Hz	The module has detected the S-BUS.	-
		Orange and green, flashing, 4 Hz	The last module is being detected in the 767 node.	Check the S-BUS terminator and/or the S-BUS cables.
		Orange, flashing, 1 Hz	The fieldbus coupler is addressing the module in the 767 node.	-
		Orange and green, flashing, 2 Hz	The S-BUS parameters are being stored by the fieldbus coupler.	-
		Orange	The firmware is being updated.	All 767 Series components are being updated by the fieldbus coupler within the node.
		Orange, flashing, 4 Hz	The module is attempting to establish communication with the fieldbus coupler.	Check the power supply to upstream 767 Series component and/or check the S-BUS cable for damages.
15	SB	Green, flashing, 1Hz	The module is in HOLD mode.	Is initiated by the fieldbus coupler. The last values transferred to the module are kept.
		Green, flashing, 2Hz	The module is in STOP mode.	Is initiated by the fieldbus coupler. The output values are set to 0.

Table 31: Operating messages 2

Pos.	LED	Color/Status	Cause	Remedy/information
16	F	Red	There is at least one global diagnostic message on the module.	Check the supply voltages U_{LS} and U_A of the upstream 767 Series components. For more information, see the section "Parameterizing" > "Diagnostic Overview".
17	I/O	Yellow	Output signal pending.	-
		Red*	Error on output.	Inspect the actuator connection for short circuit/overload or line break. If the output is switched on, any short circuit or overload that occurs can be diagnosed, an interruption cannot. If the output is switched off, only an interruption detection can be diagnosed (line break).
		* If you set the time of the parameter "Restart delay, actuator" (section "Parameterizing" > "Parameters of outputs") to 0 ms, the I/O LED appears yellow rather than red in case of a short circuit or overload due to the short restart interval.		
18	U_A	Green	Actuator supply U_A is present.	-
		Off	Actuator supply U_A is not present.	Connect the power supply and check the voltage level, if applicable.
19	U_{LS}	Green	Logic supply and sensor supply U_{LS} are present.	-
		Off	Logic supply and sensor supply U_{LS} are not present.	Connect the power supply and check the voltage level, if applicable.

10 Service

This section contains information on maintenance and service.

10.1 Updating the Firmware

The firmware for the module can be updated. This takes place via the USB connection of a fieldbus coupler. Additional information can be found in the fieldbus manuals in section "Updating the Firmware".

10.2 Replacing the Module

To replace a module, e.g., to change variants, proceed as described follow.

10.2.1 Disconnecting the Cables

Before removing the connectors, clean the module to ensure that no dirt or other material comes in contact with the connections. This can lead to damage of the contacts.

To unplug the cables, proceed as follows:

1. Disconnect the power supply from those devices on which you have mounted the module.



CAUTION

Hot connection sockets!

Even when taking into account derating, high surface temperatures on the metallic connection sockets and on the enclosure can arise during operation. If the 767 Series component has been in operation, allow it to cool off before moving it.

2. Unscrew all screw connections and remove the cables.

10.2.2 Removing the Module from Your System

To remove the module from your system's framework, proceed as follows:

1. Disconnect the power supply from those devices on which you have mounted the module.
2. Release the module from your system by unscrewing the M4 screws.

10.2.3 Removing the Module from the Carrier Rail

In order to keep the representation unambiguous, the carrier rail adapter in the following figure (B, C) is shown without module.

If the module is mounted on a carrier rail, proceed with the removal as follows:

1. Disconnect the power supply from those devices on which you have mounted the module.
2. To remove the module, press down the release actuator of the carrier rail adapter using a slot screwdriver (B) and remove it from the carrier rail (C).

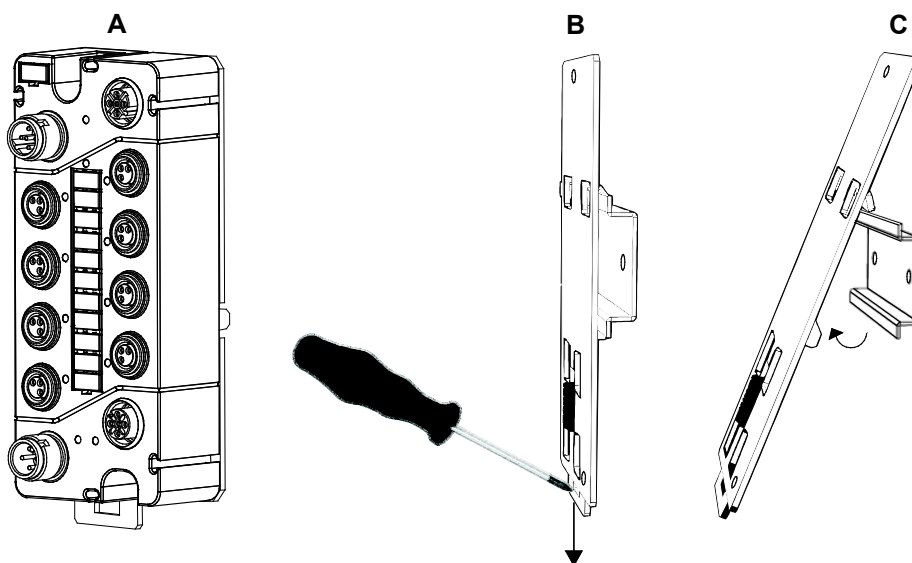

Figure 21: Removing the module (with the carrier rail adapter) from the carrier rail

10.2.4 Removing the Module from the Profile Adapter

If the module is mounted on a profile adapter, proceed with the removal as follows:

1. Disconnect the power supply from that part of the system on which you have mounted the module before attempting to remove it.
2. Unscrew the screws on which the nuts are fastened and remove the module from the profile rail of your system.
3. Unscrew the screws that connect the module with the profile adapter.

10.2.5 Connecting the Module

To connect the module, proceed as described in Sections 4 through 6. If necessary, the parameters of the previous module are transferred to the new module, depending on the type of fieldbus coupler being used. For more information, see section "Parameterizing" > "Automatic Storage of System Parameters".

10.3 Disposal

Do not dispose of the 767 Series components in the household waste; observe the laws which apply to them. You can also contact a certified waste management company.

11 Use of the Interference-Free Module in Safety Applications

Due to its interference-free feature, this module is suitable for passive use in safety circuits.

If the field side supply is shut down via a safety switching device, the safety function of the module is not active. When the interference-free module is used correctly in a safety-related application, neither the SIL or Performance Level achieved by the circuit nor the Category will be influenced. This requires that you adhere to the following notes and connection diagrams:

11.1 Important Notes

NOTICE

Only use SELV/PELV power supplies!

Only a power supply unit with protective extra-low voltage (SELV/PELV) shall be used for the 24V power supply.

NOTICE

Prevent short circuits to external voltages on the digital outputs!

A short circuit of a digital output to external voltages (e.g. 24V field voltage supplies) leads to backward infeed of the field voltage and loss of the safety function. To eliminate the possibility of an error, connecting cables between the outputs of the interference-free modules and the actuators must be laid protected in accordance with EN 60204-1 or EN ISO 13849-2.

NOTICE

Short circuits between two digital outputs!

The safety switching device does not recognize a short circuit between two digital outputs of interference-free modules. The two-channel shutdown based on interference-free module is no safety function, but is only used to functionally shut down actuators.

11.2 General Measures and Conditions for the Power Supply Solution of the Module

WARNING

Prevent conductive pollution!

Conductive pollution in the connection sockets of the power supply connections for voltages UA and ULS can be prevented through suitable measures. Before establishing the connection, inspect the contact areas for dirt and debris. Only use clean tools and materials when handling the modules.

WARNING

Tighten connectors with torque!

To achieve protection class IP67, the connectors must be tightened at a torque of 0.6 Nm. Otherwise, the safe shutdown of the I/O module by a safety switching device in the case of penetrating pollution cannot be ensured.

WARNING

Observe connecting cable specification!

The values indicated in the specification for the connecting cables regarding the environmental characteristics and mechanical load capacity must never be exceeded.

WARNING

Use safety switching device with diagnostic functions!

The safety switching device must have diagnostic functions, which ensure detection of the external power supply, so that an accumulation of errors does not lead to loss of the safety function.

WARNING

When connecting the wire ends to the connectors, prevent the strands from fraying!

If a prefabricated cable from WAGO is not used, then prevent the strands of the wire ends from fraying when connecting the cable to the connectors. A short circuit in the connector can otherwise lead to loss of the safety function. If necessary, check the insulation of the wires to each other using a high-voltage test, for example.

WARNING

Protect supply voltages using an external fuse!

Both supply voltages U_A and U_{LS} must be protected using a suitable external fuse to ensure that the current flow remains uninterrupted in case of error. U_A and U_{LS} can each be protected using a safety fuse according to EN 60127-2 or electronic fuse, e.g. WAGO 787-861. Safety fuses according to EN 60127-2 must meet the following technical requirements:

- G fuse link (e.g. WAGO Order No. 282-122)
 - Rated current 4 A
 - Time lag
 - Surge resistant
 - Large or increased breaking capacity
 - Rated voltage ≥ 60 V DC
 - Time-current characteristic: 275 % from rated current corresponding to 11 A maximum 80 s
-

11.3 Measures and Conditions for Shielded Power Supply of the Module

⚠ WARNING

Shielded version of U_A and $0 V_{U_A}$ in connecting lead for unprotected installation required!

To prevent a short circuit of power supply U_A with an external voltage, wires U_A and $0 V_{U_A}$ must be shielded in the connecting lead according to EN 60204-1 or EN ISO 13849-2. The shield must have an overlap of at least 85 % and be reliably connected to the connector.

⚠ WARNING

Attach ground shield or use insulation monitoring!

The connecting lead ground shield and functional grounding connection of the interference-free modules must be connected to lines $0 V_{U_{LS}}$ and $0 V_{U_A}$. In addition, insulation monitoring according to EN 61557 can also be used. See the following illustrations:

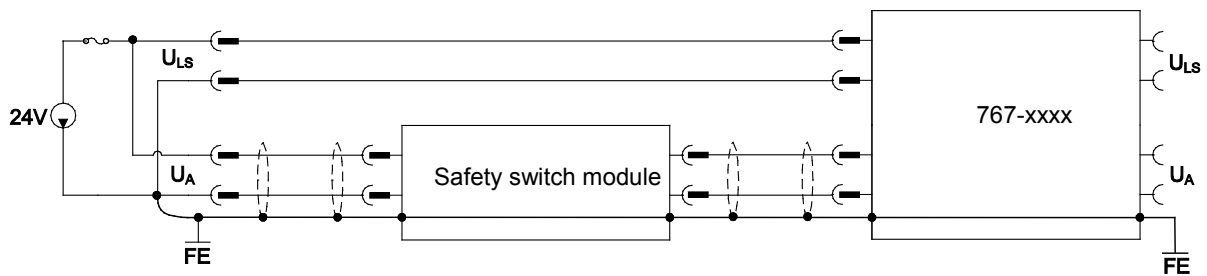

Figure 22: Connection diagram for the common power supply

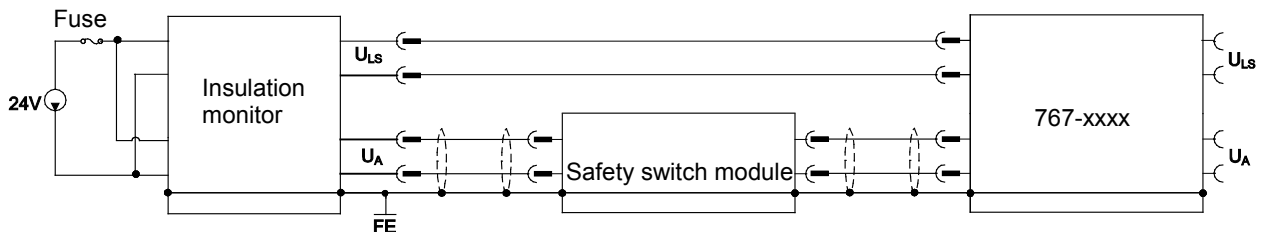

Figure 23: Connection diagram for the common power supply with insulation monitoring

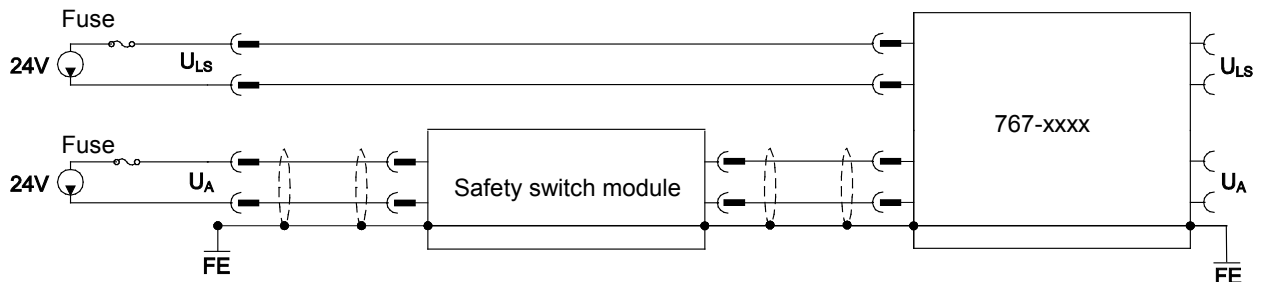

Figure 24: Connection diagram for the isolated power supply

11.4 Measures and Conditions for Unshielded Power Supply of the Module

WARNING

Measures when using connecting cables with no shielding!

If you use unshielded connecting cables to supply interference-free modules, you are required to install the connecting cables according to EN 60204-1 or EN ISO 13849-2 in a cable duct, armored conduit or shielded installation space. The measures must be suitable to ensure fault exclusion (short circuit between any two conductors) according to EN 60204-1 or EN ISO 13849-2. The fault exclusion must apply to supply voltages U_A and external voltages (e.g. U_{LS}). Please also note the cable routing in the outlet area of the protective measure (e.g. outlet area from the armored conduit/cable duct).

11.5 Connection of the Module to Safety Switching Devices

11.5.1 General Structure of a Potential Group

When using the interference-free module in safety-related applications, you must combine the interference-free modules belonging to one safety switching device in a potential group. The power supply U_A of the interference-free module may only be connected to the digital output of a suitable safety switching device (24 V).

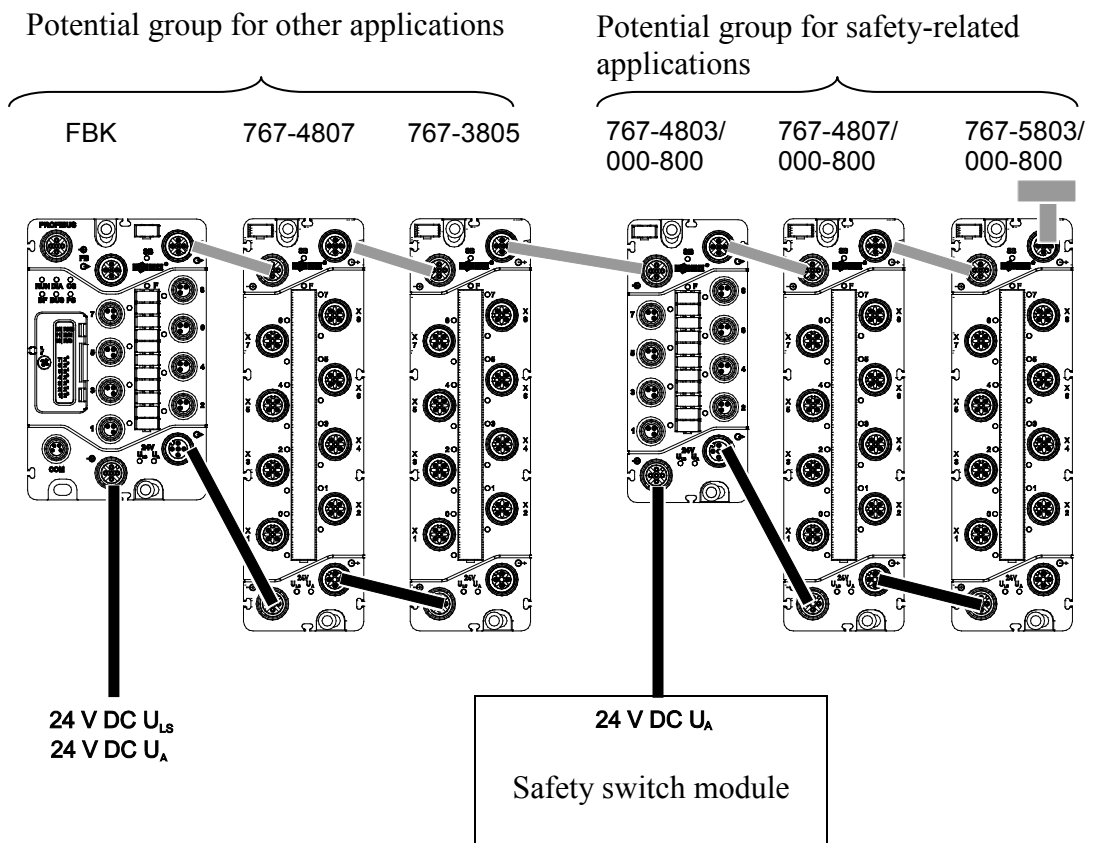

Figure 25: Example structure of potential groups

11.5.2 Examples of Connection

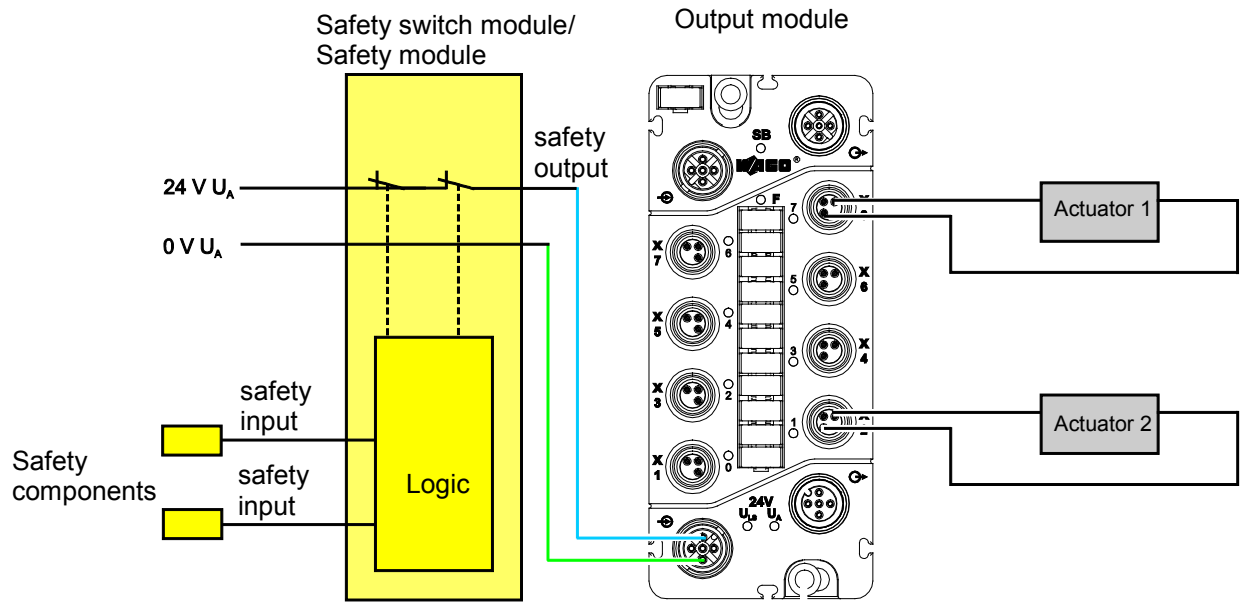

Figure 26: Single pin shutdown of the power supply of all digital outputs

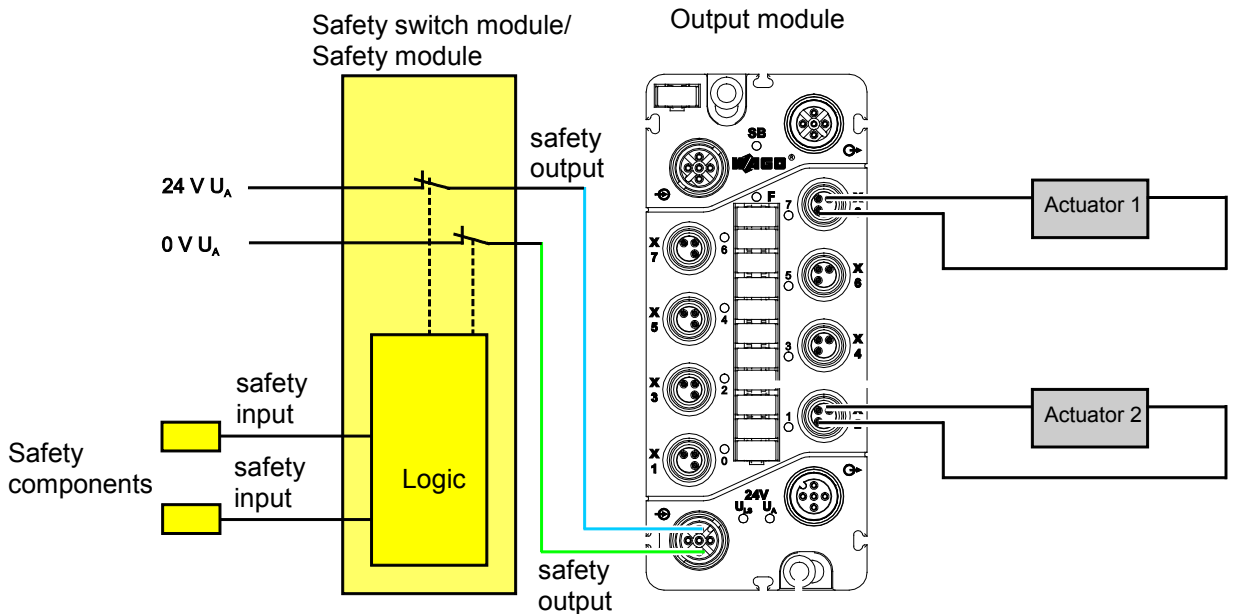

Figure 27: Two-pin shutdown of the power supply of all digital outputs

12 Appendix

12.1 Diagnostic Information

Some fieldbus couplers display the error code in the form of an attribute path (CIA), through which diagnostics are clearly assigned. Other fieldbus couplers (e.g., PROFINET I/O or PROFIBUS DP) convert the attribute path into a fieldbus-specific message.

The following diagnostic codes can be generated by the module:

Table 32: Diagnostics of the module

Diagnostic Message	Attribute Path			Classification
	C	I	A	
Low voltage U_{LS} (sensor supply)	50	1	128	Diagnostic alarm
Low voltage U_A (actuator supply)	50	1	129	Diagnostic alarm

Table 33: Diagnostics of the individual channels of the module

Diagnostic Message	Attribute Path			Classification
	C	I	A	
Actuator short circuit/overload This function is only enabled when the actuator output is switched on.	9	Channel (1 ... 8)	128	Diagnostic alarm
Actuator open load (line break) This function is only enabled when the actuator output is switched off.	9	Channel (1 ... 8)	129	Diagnostic alarm
Overtemperature This function is only enabled when the actuator output is switched on.	9	Channel (1 ... 8)	130	Diagnostic alarm

Use the "Diagnostic Overview" to disable specific diagnostics.

List of Figures

Figure 1: Connectors (exemplary).....	16
Figure 2: Marking possibilities and fastening (exemplary).....	17
Figure 3: Display elements (exemplary)	18
Figure 4: Labeling (exemplary).....	19
Figure 5: Label on the module	20
Figure 6: Schematic diagram.....	21
Figure 7: Dimensions of the module in millimeters (exemplary)	22
Figure 8: Mounting the module on the grounded system.....	32
Figure 9: Fastening to the carrier rail adapter	33
Figure 10: Mounting the carrier rail adapter (exemplary).....	34
Figure 11: Fastening to the profile adapter	35
Figure 12: Replacing the marking spaces.....	37
Figure 13: Attaching a spacer to a module.....	38
Figure 14: Attaching another module with a spacer.....	39
Figure 15: S-BUS connected to a fieldbus coupler and modules.....	43
Figure 16: Supply cable connected to the fieldbus coupler, I/O module and 2-A module.....	45
Figure 17: Connectors (exemplary).....	47
Figure 18: Example of an open DTM, including parameters	50
Figure 19: Example of the diagnostic overview of a module (information may differ from the actual module).....	52
Figure 20: LEDs indicating operational messages (exemplary)	63
Figure 21: Removing the module (with the carrier rail adapter) from the carrier rail	67
Figure 22: Connection diagram for the common power supply.....	72
Figure 23: Connection diagram for the common power supply with insulation monitoring.....	72
Figure 24: Connection diagram for the isolated power supply	72
Figure 25: Example structure of potential groups	74
Figure 26: Single pin shutdown of the power supply of all digital outputs	75
Figure 27: Two-pin shutdown of the power supply of all digital outputs.....	75

List of Tables

Table 1: Number Notation.....	9
Table 2: Font Conventions	9
Table 3: Legend for figure "Connectors"	16
Table 4: Legend for figure "Marking possibilities and fastening"	17
Table 5: Legend for figure "Display elements"	18
Table 6: Legend for figure "Labeling"	19
Table 7: Description of manufacturing number	20
Table 8: Technical Data – General Information.....	23
Table 9: Technical data – Supply	23
Table 10: Technical data – Communication.....	23
Table 11: Technical data – Outputs.....	24
Table 12: Technical data – Information on Selecting the Actuator	25
Table 13: Technical data – Influence of Operating States on Output	25
Table 14: Technical data – Configurable Functions	26
Table 15: Technical data – Diagnostics	26
Table 16: Technical data – Process Image	26
Table 17: Technical data – Display Elements	26
Table 18: Technical data – Isolation	26
Table 19: S-BUS connection assignment.....	42
Table 20: Connection assignment of digital outputs	46
Table 21: DTM buttons	50
Table 22: Information on the module.....	51
Table 23: Diagnostics setup	52
Table 24: Information about existing module diagnostics	53
Table 25: Information about an existing channel diagnostic	53
Table 26: Overview of adjustable parameters for the digital outputs	54
Table 27: Overview of parameters for the entire module	56
Table 28: Output data in the process image	59
Table 29: Input data in the process image	61
Table 30: Operating messages 1	63
Table 31: Operating messages 2.....	65
Table 32: Diagnostics of the module.....	76
Table 33: Diagnostics of the individual channels of the module	76

WE! INNOVATE!

WAGO Kontakttechnik GmbH & Co. KG
Postfach 2880 • D-32385 Minden
Hansastraße 27 • D-32423 Minden
Phone: 05 71/8 87 – 0
Fax: 05 71/8 87 – 1 69
E-Mail: info@wago.com
Internet: <http://www.wago.com>

