

# 10 Bit A/D Converter in DIN-Rail-Mountable Enclosure

1/2

Input signal 0-10 V

Data sheet

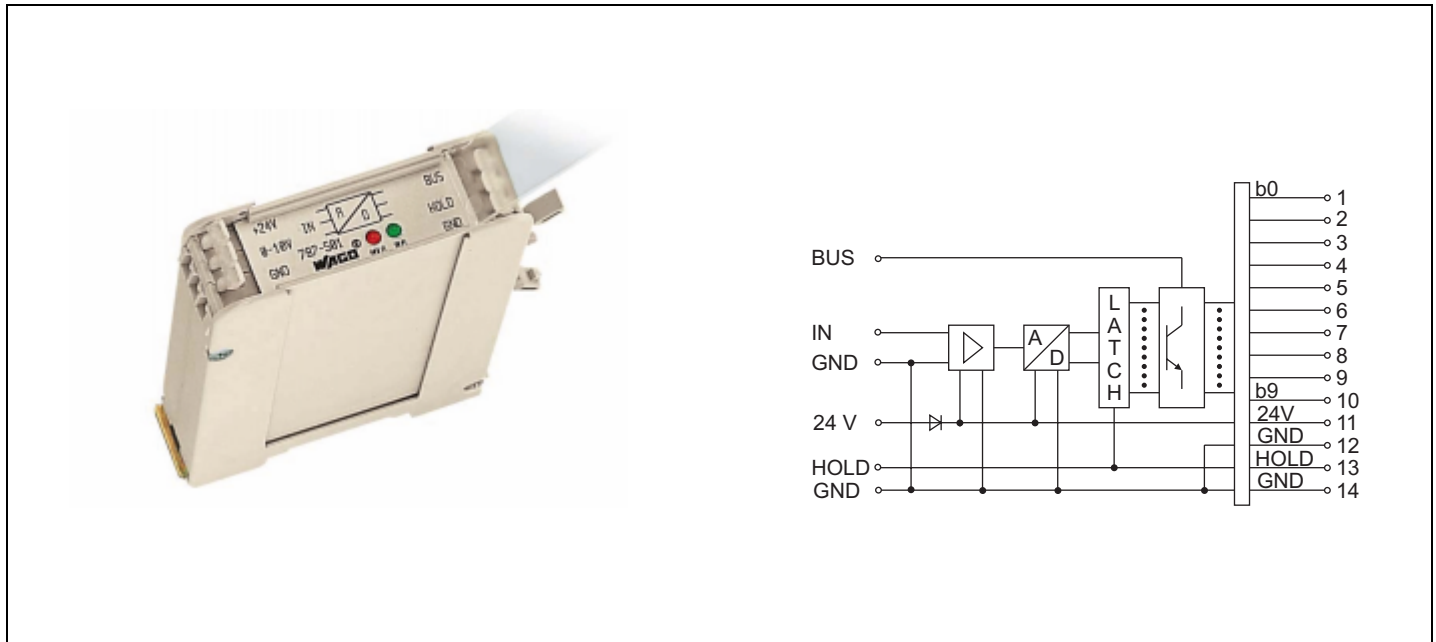

Description	Item-No.	Pack.-unit pcs																																												
Input signal 0-10 V	787-501	1																																												
<ul style="list-style-type: none"> <li>LED status indication for BUS and HOLD signals.</li> <li>DIN-rail-mountable enclosure acc. to EN 50022.</li> <li>14-pole flat cable connector acc. to DIN 41651.</li> </ul> <p>A/D converters are used for the conversion of standard analogue signals into digital signals, allowing digital computers or programmable logic controllers (PLCs) to process analogue signals using the digital inputs.</p> <p>Any number of A/D converters can be connected either to the digital BUS interface of the computer or to the digital inputs of the PLC. Specific converters can be individually selected with BUS and HOLD signals for data reception.</p> <p>The BUS input is used to select one of the A/D converters which are connected in parallel. Synchronous data reception is possible via HOLD signal controlling. Without HOLD signal controlling, the A/D converter is in the free-running mode.</p>	<p><b>Technical Data</b></p> <p><b>Input:</b></p> <table border="1"> <tr><td>Input signal</td><td>0-10 V</td></tr> <tr><td>Max. input signal</td><td>13 V</td></tr> <tr><td>Input resistance</td><td>200 kΩ</td></tr> <tr><td>Resolution (1 LSB)</td><td>9.7 mV</td></tr> <tr><td>Sampling rate (free-running mode)</td><td>1 kHz</td></tr> </table> <p>Control signals (BUS, HOLD)</p> <table border="1"> <tr><td>Input level 1-signal "H"</td><td>DC 20-30 V</td></tr> <tr><td>0-signal "L"</td><td>&lt;5 V or open connection</td></tr> </table> <p><b>Output:</b></p> <table border="1"> <tr><td>Output signal</td><td>10 bits</td></tr> <tr><td>Output level 1-signal "H"</td><td><math>U_B - 3 V</math></td></tr> <tr><td>0-signal "L"</td><td>Open output</td></tr> <tr><td>Max. output current</td><td>20 mA / bit</td></tr> </table> <p><b>General data:</b></p> <table border="1"> <tr><td>Supply voltage <math>U_B</math></td><td>DC 24 V</td></tr> <tr><td>Supply voltage range</td><td><math>U_B \pm 10 \%</math></td></tr> <tr><td>Current consumption</td><td>75 mA</td></tr> <tr><td>Protective measure</td><td>Suppressor diode</td></tr> <tr><td>Transmission error</td><td><math>\pm 1</math> LSB</td></tr> <tr><td>Ambient operating temperature</td><td>0 °C...+55 °C</td></tr> <tr><td>Storage temperature</td><td>-40 °C...+80 °C</td></tr> <tr><td>Dimensions (WxHxD)</td><td>(22,5x105*x74) mm (0.89x4.13*x2.91) in</td></tr> <tr><td>Wire connection</td><td>CAGE CLAMP® (WAGO series 257) 0,08-2,5 mm² / AWG 28-12</td></tr> <tr><td>Stripped length</td><td>5-6 mm / 0.22 in</td></tr> <tr><td>BUS interface</td><td>Flat cable connector 14-pole acc. to DIN 41651</td></tr> </table>		Input signal	0-10 V	Max. input signal	13 V	Input resistance	200 kΩ	Resolution (1 LSB)	9.7 mV	Sampling rate (free-running mode)	1 kHz	Input level 1-signal "H"	DC 20-30 V	0-signal "L"	<5 V or open connection	Output signal	10 bits	Output level 1-signal "H"	$U_B - 3 V$	0-signal "L"	Open output	Max. output current	20 mA / bit	Supply voltage $U_B$	DC 24 V	Supply voltage range	$U_B \pm 10 \%$	Current consumption	75 mA	Protective measure	Suppressor diode	Transmission error	$\pm 1$ LSB	Ambient operating temperature	0 °C...+55 °C	Storage temperature	-40 °C...+80 °C	Dimensions (WxHxD)	(22,5x105*x74) mm (0.89x4.13*x2.91) in	Wire connection	CAGE CLAMP® (WAGO series 257) 0,08-2,5 mm² / AWG 28-12	Stripped length	5-6 mm / 0.22 in	BUS interface	Flat cable connector 14-pole acc. to DIN 41651
Input signal	0-10 V																																													
Max. input signal	13 V																																													
Input resistance	200 kΩ																																													
Resolution (1 LSB)	9.7 mV																																													
Sampling rate (free-running mode)	1 kHz																																													
Input level 1-signal "H"	DC 20-30 V																																													
0-signal "L"	<5 V or open connection																																													
Output signal	10 bits																																													
Output level 1-signal "H"	$U_B - 3 V$																																													
0-signal "L"	Open output																																													
Max. output current	20 mA / bit																																													
Supply voltage $U_B$	DC 24 V																																													
Supply voltage range	$U_B \pm 10 \%$																																													
Current consumption	75 mA																																													
Protective measure	Suppressor diode																																													
Transmission error	$\pm 1$ LSB																																													
Ambient operating temperature	0 °C...+55 °C																																													
Storage temperature	-40 °C...+80 °C																																													
Dimensions (WxHxD)	(22,5x105*x74) mm (0.89x4.13*x2.91) in																																													
Wire connection	CAGE CLAMP® (WAGO series 257) 0,08-2,5 mm² / AWG 28-12																																													
Stripped length	5-6 mm / 0.22 in																																													
BUS interface	Flat cable connector 14-pole acc. to DIN 41651																																													

# 10 Bit A/D Converter in DIN-Rail-Mountable Enclosure

Input signal 0-10 V

Data sheet

**IN Analog-input**

- 0-10V**      **Item-No. 787-501**
- 0-20mA      *Item-No. 787-502*
- 4-20mA      *Item-No. 787-503*

**B BUS input**

A high level triggers the digitaly converted data word to the data BUS.  
A low level inactivates the BUS drivers, thus allowing another parallel connected A/D converters to transmit data to the data BUS. The internal conversion of the signal is being continued!

**H HOLD input**

A high level allows storage of the currently converted value of the A/D converter.  
A low level deactivates the storage function of the device, thus allowing the pending analogue values to be continually converted and to be available on the data BUS.

**b0...b9 Data BUS**

The digital outputs are used to trigger the PLC or the computer system via the flat cable connector.

**Us Voltage supply**

A 24V input voltage supplies the A/D converter.

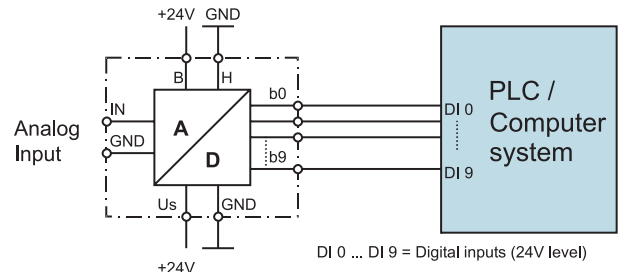

Fig.1 Individual mode with continuous conversion

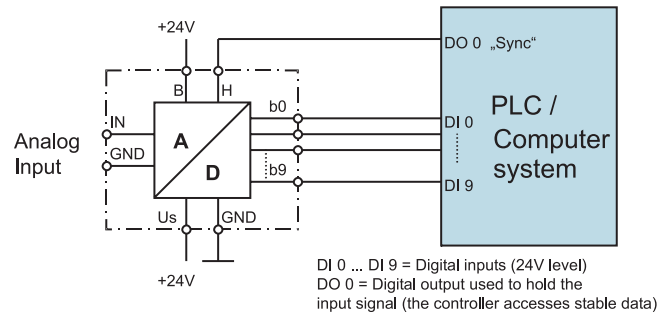

Fig.2 Individual mode with "HOLD control"

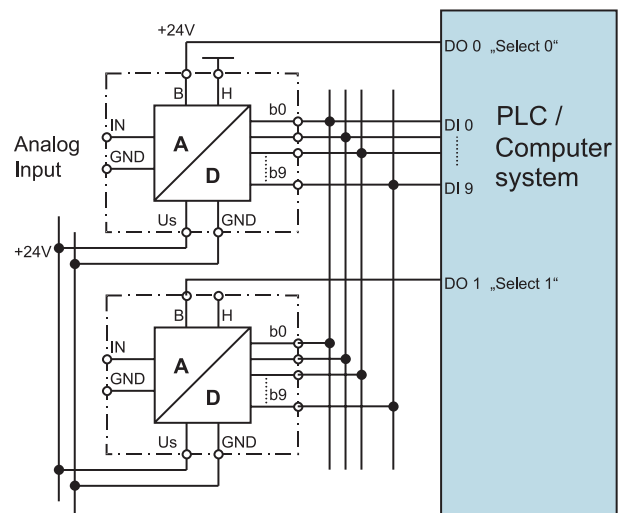

Fig.3 BUS operation with continuous conversion