

WAGO I/O System 750/753

4-channel digital output; 24 VDC; 0.5 A; interference-free

750-504/000-800; 750-504/025-800



© 2025 WAGO GmbH & Co. KG
All rights reserved.

WAGO GmbH & Co. KG

Hansastraße 27
D - 32423 Minden

Phone: +49 571/887 – 0
E-Mail: ✉ info@wago.com
Internet: 🌐 www.wago.com

Technical Support

Phone: +49 571/887 – 44555
E-Mail: ✉ support@wago.com
Internet: 🌐 www.wago.com/support

Every conceivable measure has been taken to ensure the accuracy and completeness of this documentation. However, as errors can never be fully excluded, we always appreciate any information or suggestions for improving the documentation.

E-Mail: ✉ documentation@wago.com

We wish to point out that the software and hardware terms as well as the trademarks of companies used and/or mentioned in the present manual are generally protected by trademark or patent.

WAGO is a registered trademark of WAGO Verwaltungsgesellschaft mbH.

Table of Contents

1 Provisions	4
1.1 Scope of Applicability	4
2 Overview	5
3 Properties	6
3.1 View.....	6
3.2 Indicators.....	7
3.3 Wiring Interface.....	7
3.4 Power Jumper Contacts.....	8
3.5 Circuit Diagram.....	9
4 Functions	10
4.1 Signal Processing.....	10
4.2 Process Image	10
5 Planning	11
5.1 Compatibility.....	11
5.2 Requirements for Wiring and Accessories	11
5.3 Connection Examples	11
5.4 Use in Safety Applications.....	12
5.4.1 Connection to Safety Switching Devices or F I/O Modules	13
5.4.2 Connection Examples for Use in Safety Applications.....	14
6 Appendix	15
6.1 Technical Data, Approvals, Guidelines and Standards.....	15
6.1.1 Data sheet 750-504/000-800.....	16
6.1.2 Data sheet 750-504/025-800.....	19

1 Provisions

1.1 Scope of Applicability

This document applies to the following products:

🔗 **750-504/000-800** (4DO 24V DC 0.5A/R) 4-channel digital output; 24 VDC; 0.5 A; interference-free.

From hardware version	15
From firmware version	--
Product detail page	🔗 www.wago.com/750-504

🔗 **750-504/025-800** (2DO 24V DC 0.5A/T/R) 2-channel digital output; 24 VDC; 0.5 A; ext. temperature; interference-free.

From hardware version	13
From firmware version	--
Product detail page	🔗 www.wago.com/750-504/025-800

Note

Note applicable documents!

The complete operating instructions for the products consist of several applicable documents. The products must only be installed and operated in accordance with the complete operating instructions. Knowledge of all applicable documents is required for proper use. Please find all documents and information on the detailed product pages.

Applicable document

System Manual I/O System 750/753

- Provisions
- Safety
- Planning
- Transport and Storage
- Assembly and Disassembly
- Conductor Termination
- Decommissioning

2 Overview

The I/O module transmits binary control signals to connected actuators (e.g., magnetic valves, contactors, transmitters, relays or other electrical loads).

The I/O module has four output channels, allowing direct connection of 2-wire actuators.

The I/O module's outputs are short-circuit-protected.

The interference-free I/O module is suitable for use in safety-related applications. See the information in section [🔗 Use in Safety Applications \[▶ 12\]](#).

The I/O module's outputs provide high-side switching. If the signal status of an output channel is "high," the 24 V potential for the field power supply is switched to the corresponding output connection.

For each channel, a green status LED indicates the signal status.

The field level and the system level are electrically isolated from one another.

The I/O module can be operated on all head stations of the WAGO I/O System 750/753.

3 Properties

3.1 View

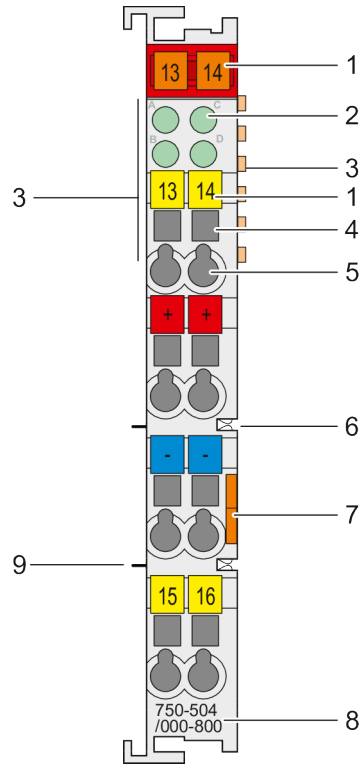

Figure 1: View

1	Slot for Mini-WSB (optional)	☐ System Manual I/O System 750/753
2	Status LEDs	🔗 Indicators [> 7]
3	Data contacts	☐ System Manual I/O System 750/753
4	Access to open the associated CAGE CLAMP® connection	☐ System Manual I/O System 750/753
5	CAGE CLAMP® connections	🔗 Wiring Interface [> 8] and ☐ System Manual I/O System 750/753
6	Power jumper contacts (spring)	🔗 Power Jumper Contacts [> 8] and ☐ System Manual I/O System 750/753
7	Release tab	☐ System Manual I/O System 750/753
8	Item number	🔗 Scope of Applicability [> 4]
9	Power jumper contacts (blade)	🔗 Power Jumper Contacts [> 8] and ☐ System Manual I/O System 750/753

3.2 Indicators

For each channel, a green status LED indicates the signal status.

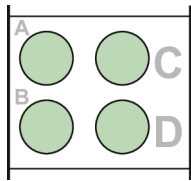

Figure 2: Indicators

Channel	Designation	LED	State	Function
1	DO 1 status	A	Off	DO 1 output: signal voltage (0)
			Green	DO 1 output: signal voltage (1)
2	DO 2 status	C	Off	DO 2 output: signal voltage (0)
			Green	DO 2 output: signal voltage (1)
3	DO 3 status	B	Off	DO 3 output: signal voltage (0)
			Green	DO 3 output: signal voltage (1)
4	DO 4 status	D	Off	DO 4 output: signal voltage (0)
			Green	DO 4 output: signal voltage (1)

3.3 Wiring Interface

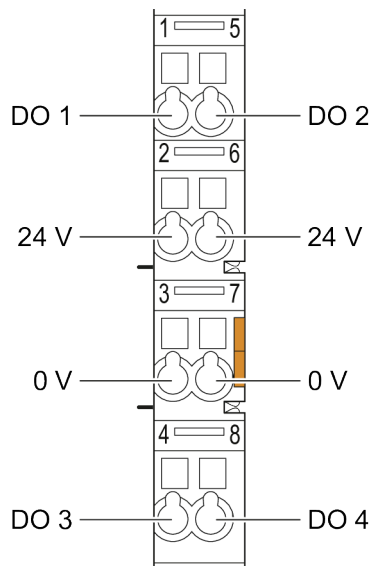

Figure 3: CAGE CLAMP® Connections

Channel	Designation	Connection	Function
1	DO 1	1	Output DO 1: signal voltage
2	DO 2	5	Output DO 2: signal voltage
3	DO 3	4	Output DO 3: signal voltage
4	DO 4	8	Output DO 4: signal voltage
-	24 V	2	Field supply +24 V
	24 V	6	Field supply +24 V
	0 V	3	Field supply 0 V
	0 V	7	Field supply 0 V

3.4 Power Jumper Contacts

The potential for the field supply is fed in via the blade contacts and passed on via the spring contacts.

For additional information on the Power Jumper Contacts, please see [System Manual I/O System 750/753](#).

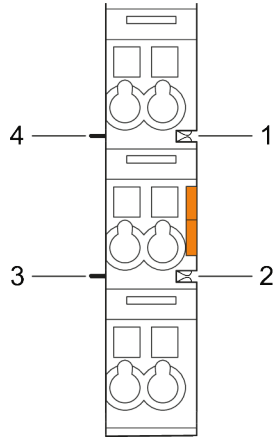

Figure 4: Power Jumper Contacts

No.	Type
1	Groove with spring contact
2	
3	Blade contact
4	

Arrangement in the Bus Node

For mechanical arrangement of the I/O module, the previous component must have at least 2 open grooves for accommodating the blade contacts.

For electrical compatibility requirements see Section [Circuit Diagram \[▶ 9\]](#).

3.5 Circuit Diagram

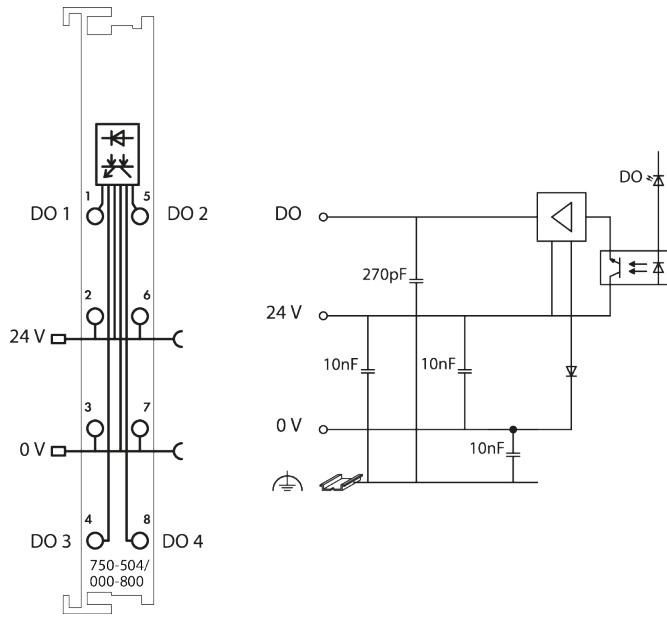

Figure 5: Schematic Circuit Diagram (Hardware Version 12 or higher)

For information on the system power supply, please see [System Manual I/O System 750/753](#).

4 Functions

4.1 Signal Processing

The I/O module’s outputs provide high-side switching. If the signal status of an output channel is “high,” the 24 V potential for the field power supply is switched to the corresponding output connection.

4.2 Process Image

Table 1: Process Image–Output

	Bit 3	Bit 2	Bit 1	Bit 0
	DO 4	DO 3	DO 2	DO 1
DO 1	DO 1 signal state – digital output channel 1			
DO 2	DO 2 signal state – digital output channel 2			
DO 3	DO 3 signal state – digital output channel 3			
DO 4	DO 4 signal state – digital output channel 4			

5 Planning

This section provides helpful information for planing the use of the product in a node.

5.1 Compatibility

The I/O module can be operated on all head stations of the WAGO I/O System 750/753.

5.2 Requirements for Wiring and Accessories

To protect the I/O module against overload, use a supply module with a fuse (e.g., item no.: [750-601](#) or [750-610](#)).

If applicable, use appropriate potential multiplication modules (item no.: [750-614](#)) for the power supply to the actuators.

Use a suitable protective circuit to limit the induction voltage, such a recovery diode, parallel to the load. Inductive voltage limitation prevents damage to the I/O module's electronics when inductive loads are switched off.

5.3 Connection Examples

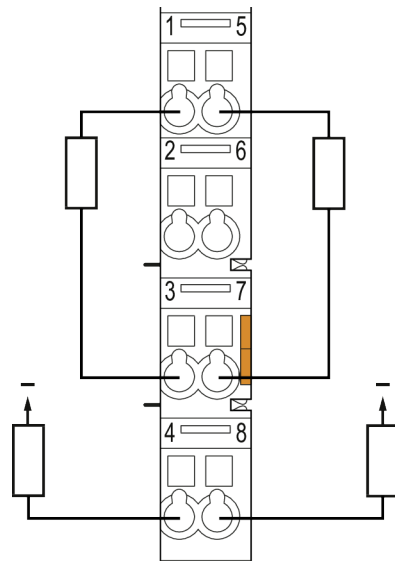

Figure 6: 2-Wire Connection

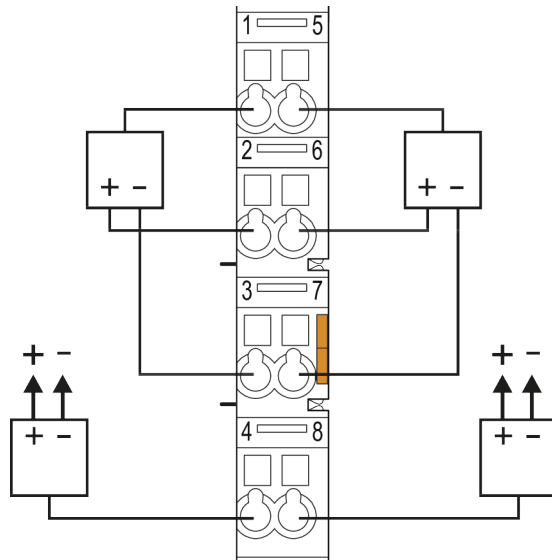

Figure 7: 3-Wire Connection

5.4 Use in Safety Applications

The I/O module is suitable for interference-free use in safety circuits.

If the field-side supply is shut down via a safety switching device, the safety function of the I/O module is not active. If the interference-free I/O module is used correctly in a safety-related application, this does not affect either the SIL (or the Performance Level and category) achieved by the circuit. Note the following information.

- **Only operate with functional extra-low voltage**
When using interference-free I/O modules, only use SELV/PELV-capable power supplies for the 24 VDC power supply.
- **Observe maximum voltage**
Even in the event of failure, only a maximum voltage of U_{\max} must be allowed to act on the interference-free I/O module; otherwise irreparable damage to the I/O module could occur. Use a power supply with active voltage limitation (overvoltage protection) or an alternate component. For the interference-free I/O module, the field supply voltage is:
 $U_{\max} < 32 \text{ V}$
- **Ensure protection type IP54**
Protection type IP54 is mandatory. Therefore, integration and operation of the interference-free I/O module is only allowed in switch boxes or control cabinets with protection type IP54 or higher.
- **Protect the outputs against feedback**
The 24 V power supply must never be applied to the output of an interference-free I/O module. The system would not detect such a wiring error.
- **Avoid reverse power supply of the I/O module**
A group of interference-free I/O modules must only be powered by a safety switching device. It is absolutely essential to avoid reverse power supply.
- **Prevent short circuits between outputs**
It is absolutely essential to prevent short circuits between the outputs of different interference-free I/O modules. The system would not detect such short circuits.

According to EN ISO 13849-2, the following measures are required for an “external voltage” fault exclusion:

- Use of cables routed separately and
- Protection from external damage (e.g., with cable duct).

5.4.1 Connection to Safety Switching Devices or F I/O Modules

When the interference-free I/O module is used in safety-related applications, the I/O modules belonging to a safety switching device must be combined to form a potential group. The power supply of the potential group must only be provided via the following supply/filter modules:

Table 2: Supply/Filter Modules for Setting up a Potential Group

Supply module	Item no.: 750-601
	Item no.: 750-602
Filter module	Item no.: 750-626

Either a supply module or a distance module without power jumper contacts (item no.: [750-616](#)) must be connected at the end of the potential group.

Safety switching device /
F I/O module

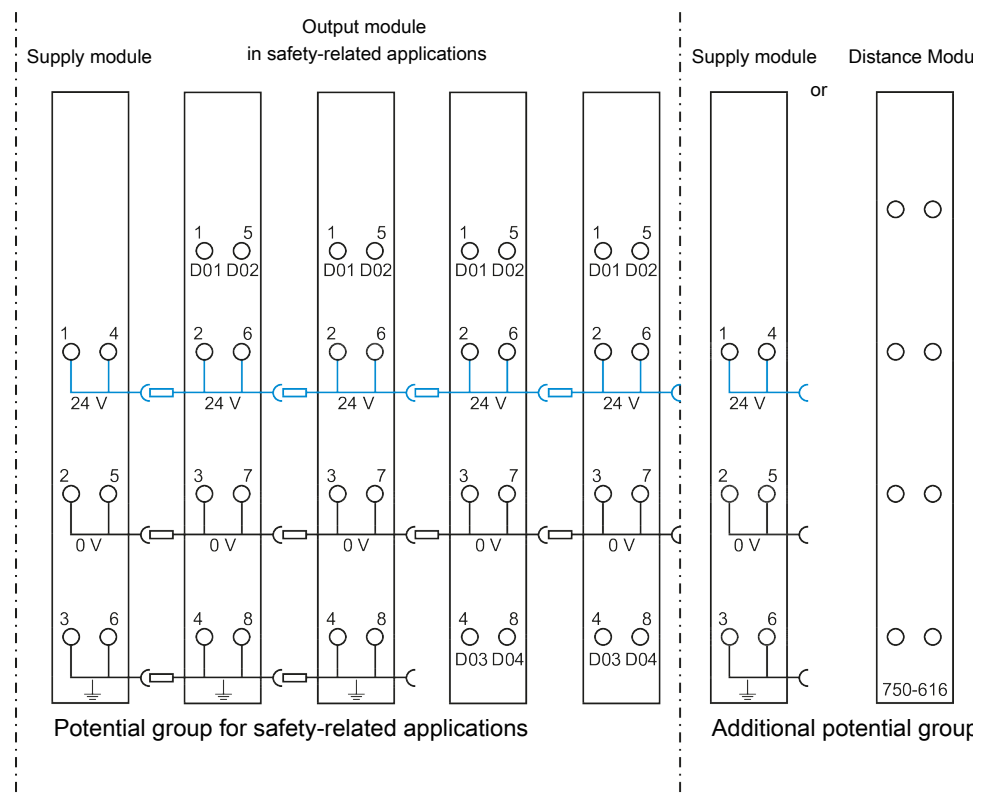

Figure 8: Setting Up a Potential Group (Example)

5.4.2 Connection Examples for Use in Safety Applications

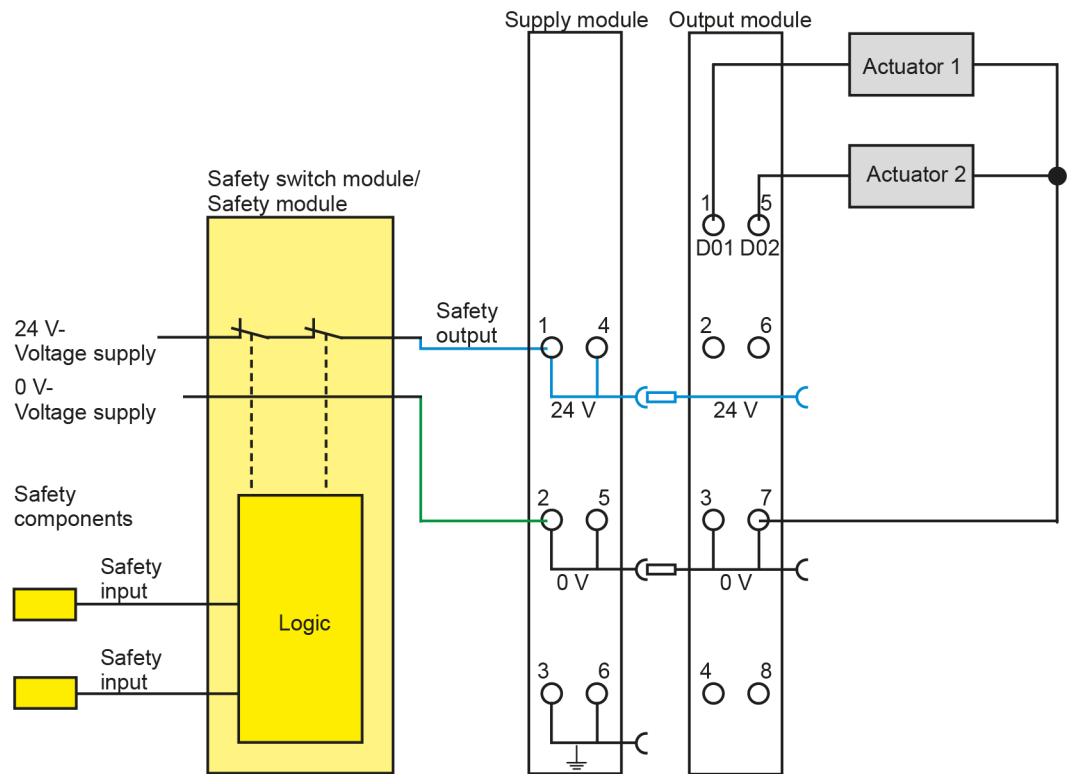

Figure 9: Two-Channel, **Single-Pole** Power Supply Disconnection

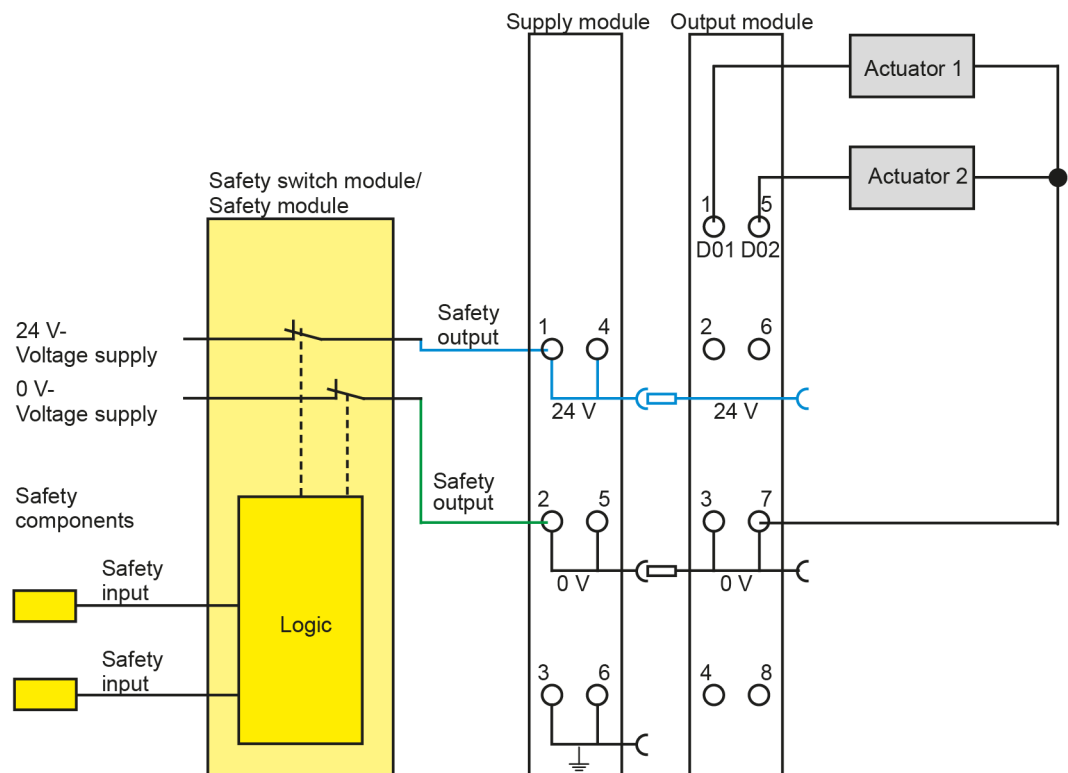

Figure 10: Two-Channel, **Two-Pole** Power Supply Disconnection

6 Appendix



6.1 Technical Data, Approvals, Guidelines and Standards

Note

Subject to changes!

Please also observe the further product documentation! You can generate the current datasheet at any time at: www.wago.com /<item number>.

See also

-  Data sheet 750-504/000-800 [▶ 16]
-  Data sheet 750-504/025-800 [▶ 19]

Data Sheet | Item Number: 750-504/000-800
4-channel digital output; 24 VDC; 0.5 A; Interference-free

<https://www.wago.com/750-504/000-800>



This digital output module transmits control signals from the automation device to the connected actuators.
All outputs are short-circuit-protected.
Field and system levels are electrically isolated.

Technical data

Number of digital outputs	4
Total number of channels (module)	4
Signal type	Digital
Signal type (voltage)	24 VDC
Actuator connection	2 x (2-wire, 3-wire); A suitable field side connection module (e.g., 750-614) must also be used to connect other actuators.
Output characteristic	high-side switching
Output current per channel	0.5 A
Output current	short-circuit-protected
Load type	Resistive, inductive, lamp load
Switching frequency (max.)	1 kHz
Inductive load switch-off energy dissipation (max.)	0.3 J
Output data width (internal) max.	4 bits
Supply voltage (system)	5 VDC; via data contacts
Current consumption (5 V system supply)	10 mA
Supply voltage (field)	24 VDC (-25 ... +30 %); via power jumper contacts (power supply via blade contact; transmission (field side supply voltage only) via spring contact)
Current consumption, field supply (module with no external load)	30 mA
Isolation	500 V system/field
Interference-free with safety function	Yes
Indicators	LED (A-D) green: Status DO 1 ... DO 4
Number of incoming power jumper contacts	2
Number of outgoing power jumper contacts	2
Current carrying capacity (power jumper contacts)	10 A

Connection data

Connection technology: inputs/outputs	8 x CAGE CLAMP® (outputs)
Connectable conductor materials	Copper
Connection type 1	Output
Solid conductor	0.08 ... 2.5 mm ² / 28 ... 14 AWG
Fine-stranded conductor	0.08 ... 2.5 mm ² / 28 ... 14 AWG
Strip length	8 ... 9 mm / 0.31 ... 0.35 inches

Physical data

Width	12 mm / 0.472 inches
Height	100 mm / 3.937 inches
Depth	69.8 mm / 2.748 inches
Depth from upper-edge of DIN-rail	62.6 mm / 2.465 inches

Mechanical data

Mounting type	DIN-35 rail
Pluggable connector	fixed

Material data

Color	light gray
Housing material	Polycarbonate; polyamide 6.6
Fire load	1.486 MJ
Weight	48.4 g
Conformity marking	CE

Environmental requirements

Ambient temperature (operation)	0 ... +55 °C
Ambient temperature (storage)	-40 ... +85 °C
Protection type	IP20
Pollution degree	2 per IEC 61131-2
Operating altitude	0 ... 2000 m / 0 ... 6562 ft
Mounting position	Horizontal left, horizontal right, horizontal top, horizontal bottom, vertical top and vertical bottom
Relative humidity (without condensation)	95 %
Vibration resistance	4g per IEC 60068-2-6
Shock resistance	15g per IEC 60068-2-27
EMC immunity to interference	per EN 61000-6-2, marine applications
EMC emission of interference	per EN 61000-6-4, marine applications
Exposure to pollutants	per IEC 60068-2-42 and IEC 60068-2-43
Permissible H ₂ S contaminant concentration at a relative humidity 75 %	10 ppm
Permissible SO ₂ contaminant concentration at a relative humidity 75 %	25 ppm

Product classification

UNSPSC	32151705
--------	----------

Environmental Product Compliance

CAS-No.	1303-86-2 1317-36-8 25550-51-0 7439-92-1 75980-60-8
REACH Candidate List Substance	4-Methyl-1,2-cyclohexanedicarboxylic anhydride Diboron trioxide Lead Lead monoxide Phosphine oxide, diphenyl(2,4,6-trimethylbenzoyl)-
RoHS Compliance Status	Compliant,With Exemption
RoHS Exemption	6(c) 7(a) 7(c)-I 7(c)-II
SCIP notification number (Austria)	a08770db-21c0-4bed-82e3-a40a37701efe
SCIP notification number (Belgium)	2a2ec452-cc3f-49ce-8ca0-11b7edf42f97
SCIP notification number (Bulgaria)	969a7672-d542-4fa8-95ec-0e32d51b6423
SCIP notification number (Czech Republic)	b305b855-7e2f-41f6-9460-0e05ef57fae2
SCIP notification number (Denmark)	18d9e0e9-e462-473b-8f52-707b340188c2
SCIP notification number (Finland)	509a241c-88bf-4a76-a6f0-2cf96fb4c3ca
SCIP notification number (France)	90548fcf-83c9-4ca3-8f23-4c10d1474699
SCIP notification number (Germany)	68fbe5f8-499e-41df-b1d5-f08d33e1bd15
SCIP notification number (Hungary)	3439fe27-dc80-4a79-b80a-c9fa8e8368d0
SCIP notification number (Italy)	4c0ce7f4-3c92-49f6-a01f-29e1b1d56f96

Environmental Product Compliance

SCIP notification number (Netherlands)	4bcd8229-9d22-4699-a7f5-9a41d446b54b
SCIP notification number (Poland)	fe35663e-1a68-429a-a2db-dd301fb349f8
SCIP notification number (Romania)	89287865-d1c4-4a1a-8aa6-d3e3fad02e5b
SCIP notification number (Sweden)	a32ed2de-e817-45e3-9be7-8383b0a0fb80

Approvals / Certificates

General approvals



Approval	Standard	Certificate Name
EAC GZO Almaty Standart	TP TC 020/2011	EAC CoC 03083
KC National Radio Research Agency	Article 58-2, Clause 3	MSIP-REM-W43-DOM750

Declarations of conformity and manufacturer's declarations

Approval	Standard	Certificate Name
EU-Declaration of Conformity WAGO GmbH & Co. KG	-	-
UK-Declaration of Conformity WAGO GmbH & Co. KG	-	-

Approvals for marine applications



Approval	Standard	Certificate Name
ABS American Bureau of Shipping	-	22-2219060
BSH Bundesamt fuer Seeschifffahrt und Hydrographie	-	1104
BV Bureau Veritas S.A.	-	30389/C0 BV
DNV DNV GL SE	DNV-CG-0339, Aug.2021	TAA0000194
KR Korean Register of Shipping	-	KR HMB05880-AC001
LR Lloyds Register EMEA	-	LR22180952TA
PRS Polski Rejestr Statków	-	TE/1101/880590/23
RINA RINA Germany GmbH	-	ELE343521XG001

Approvals for hazardous areas



Approval	Standard	Certificate Name
ATEX TUEV Nord Cert GmbH	EN 60079-0	TUEV14ATEX148929X (II 3 G Ex ec IIC T4 Gc)
CCCEX CQST/CNEX	CNCA-C23-01	2020312310000213 (Ex ec IIC T4 Gc)
IECEX TUEV Nord Cert GmbH	IEC 60079-0	IECEX TUN 14.0035 X (Ex ec IIC T4 Gc)
INMETRO TUV Rheinland do Brasil Ltda.	IEC 60079-0	TUV 12.1297 X
UKEX WAGO GmbH & Co. KG	EN 60079-0	UKCA_WA GO22UKEX003X_ec

Data Sheet | Item Number: 750-504/025-800

4-channel digital output; 24 VDC; 0.5 A; Interference-free; Ext. Temperature

<https://www.wago.com/750-504/025-800>



This digital output module transmits control signals from the automation device to the connected actuators.
All outputs are short-circuit-protected.
Field and system levels are electrically isolated.

Technical data

Number of digital outputs	4
Total number of channels (module)	4
Signal type	Digital
Signal type (voltage)	24 VDC
Actuator connection	2 x (2-wire, 3-wire); A suitable field side connection module (e.g., 750-614) must also be used to connect other actuators.
Output characteristic	high-side switching
Output current per channel	0.5 A
Output current	short-circuit-protected
Load type	Resistive, inductive, lamp load
Switching frequency (max.)	1 kHz
Inductive load switch-off energy dissipation (max.)	0.3 J
Output data width (internal) max.	4 bits
Supply voltage (system)	5 VDC; via data contacts
Current consumption (5 V system supply)	10 mA
Supply voltage (field)	24 VDC (-25 ... +30 %); via power jumper contacts (power supply via blade contact; transmission (field side supply voltage only) via spring contact)
Current consumption, field supply (module with no external load)	30 mA
Isolation	500 V system/field
Interference-free with safety function	Yes
Indicators	LED (A-D) green: Status DO 1 ... DO 4
Number of incoming power jumper contacts	2
Number of outgoing power jumper contacts	2
Current carrying capacity (power jumper contacts)	10 A

Connection data

Connection technology: inputs/outputs	8 x CAGE CLAMP® (outputs)
Connectable conductor materials	Copper
Connection type 1	Output
Solid conductor	0.08 ... 2.5 mm ² / 28 ... 14 AWG
Fine-stranded conductor	0.08 ... 2.5 mm ² / 28 ... 14 AWG
Strip length	8 ... 9 mm / 0.31 ... 0.35 inches

Physical data

Width	12 mm / 0.472 inches
Height	100 mm / 3.937 inches
Depth	69.8 mm / 2.748 inches
Depth from upper-edge of DIN-rail	62.6 mm / 2.465 inches

Mechanical data

Mounting type	DIN-35 rail
Pluggable connector	fixed

Material data

Color	light gray
Housing material	Polycarbonate; polyamide 6.6
Fire load	1.007 MJ
Weight	48.5 g
Conformity marking	CE

Environmental requirements

Ambient temperature (operation)	-20 ... +60 °C
Ambient temperature (storage)	-40 ... +85 °C
Protection type	IP20
Pollution degree	2 per IEC 61131-2
Operating altitude	0 ... 2000 m / 0 ... 6562 ft
Mounting position	Horizontal left, horizontal right, horizontal top, horizontal bottom, vertical top and vertical bottom
Relative humidity (without condensation)	95 %
Relative humidity (with condensation)	Short-term condensation per Class 3K6/IEC EN 60721-3-3 and E-DIN 40046-721-3, accounting for a temperature range of -20 to +60 °C (except for wind-driven precipitation, water and ice formation)
Vibration resistance	4g per IEC 60068-2-6
Shock resistance	15g per IEC 60068-2-27
EMC immunity to interference	per EN 61000-6-2, marine applications
EMC emission of interference	per EN 61000-6-4, marine applications
Exposure to pollutants	per IEC 60068-2-42 and IEC 60068-2-43
Permissible H ₂ S contaminant concentration at a relative humidity 75 %	10 ppm
Permissible SO ₂ contaminant concentration at a relative humidity 75 %	25 ppm

Product classification

UNSPSC	32151705
--------	----------

Environmental Product Compliance

CAS-No.	1303-86-2 1317-36-8 25550-51-0 7439-92-1 75980-60-8
REACH Candidate List Substance	4-Methyl-1,2-cyclohexanedicarboxylic anhydride Diboron trioxide Lead Lead monoxide Phosphine oxide, diphenyl(2,4,6-trimethylbenzoyl)-
RoHS Compliance Status	Compliant,With Exemption
RoHS Exemption	6(c) 7(a) 7(c)-I 7(c)-II
SCIP notification number (Austria)	0531908a-8571-4465-9248-e01edcdacbaa
SCIP notification number (Belgium)	b443aeed-e6c6-4799-9f5b-bf85efba970a
SCIP notification number (Bulgaria)	cb3b3481-cf38-4403-9adb-4c4a61cf3f89
SCIP notification number (Czech Republic)	69ab5a62-57ae-4508-80ea-ec2c569a91c9
SCIP notification number (Denmark)	72801b9e-adac-4115-b47a-df9dabcb8c70
SCIP notification number (Finland)	1371bd4e-c641-40d8-9a26-0b233d2c2a28
SCIP notification number (France)	161665a9-3441-4546-8399-5895641d257b
SCIP notification number (Germany)	d8913853-5081-4093-be7c-cc9be6e71af6

Environmental Product Compliance

SCIP notification number (Hungary)	8e579da0-f911-448d-8deb-3aae2c7dbbf7
SCIP notification number (Italy)	8b80f038-4200-4411-899a-6c5ff7979ab7
SCIP notification number (Netherlands)	9a12ca86-d7a5-4904-97c0-c3e0f023c35e
SCIP notification number (Poland)	9961c9c9-ac62-474b-964c-88ca4380aac9
SCIP notification number (Romania)	3805c094-26ee-42f2-9f75-6a1fd581da46
SCIP notification number (Sweden)	5acf9a54-ba5c-452f-a4e5-4f1bda3c2bb1

Approvals / Certificates

General approvals



Approval	Standard	Certificate Name
EAC GZO Almaty Standart	TP TC 020/2011	EAC CoC 03083
KC National Radio Research Agency	Article 58-2, Clause 3	MSIP-REM-W43-DOM750

Declarations of conformity and manufacturer's declarations

Approval	Standard	Certificate Name
EU-Declaration of Conformity WAGO GmbH & Co. KG	-	-
UK-Declaration of Conformity WAGO GmbH & Co. KG	-	-

Approvals for marine applications



Approval	Standard	Certificate Name
ABS American Bureau of Shipping	-	22-2227356-PDA
BSH Bundesamt fuer Seeschifffahrt und Hydrographie	-	1104
LR Lloyds Register	-	LR2475997TA
PRS Polski Rejestr Statków	-	TE/1102/880590/23

Approvals for hazardous areas



Approval	Standard	Certificate Name
ATEX TUEV Nord Cert GmbH	EN 60079-0	TUEV14ATEX148929X (II 3 G Ex ec IIC T4 Gc)
CCCEX CQST/CNEX	CNCA-C23-01	2020312310000213 (Ex ec IIC T4 Gc)
IECEX TUEV Nord Cert GmbH	IEC 60079-0	IECEX TUN 14.0035 X (Ex ec IIC T4 Gc)
INMETRO TUV Rheinland do Brasil Ltda.	IEC 60079-0	TUV 12.1297 X
UKEX WAGO GmbH & Co. KG	EN 60079-0	UKCA_WA GO22UKEX003X_ec

List of Tables

Table 1	Process Image–Output.....	10
Table 2	Supply/Filter Modules for Setting up a Potential Group	13

List of Figures

Figure 1	View	6
Figure 2	Indicators	7
Figure 3	CAGE CLAMP® Connections	7
Figure 4	Power Jumper Contacts	8
Figure 5	Schematic Circuit Diagram (Hardware Version 12 or higher)	9
Figure 6	2-Wire Connection	11
Figure 7	3-Wire Connection	12
Figure 8	Setting Up a Potential Group (Example).....	13
Figure 9	Two-Channel, Single-Pole Power Supply Disconnection	14
Figure 10	Two-Channel, Two-Pole Power Supply Disconnection	14

WAGO GmbH & Co. KG

Postfach 2880 · D - 32385 Minden
Hansastraße 27 · D - 32423 Minden

✉ info@wago.com
🌐 www.wago.com

Headquarters	+49 571/887 – 0
Sales	+49 (0) 571/887 – 44 222
Order Service	+49 (0) 571/887 – 44 333

WAGO is a registered trademark of WAGO Verwaltungsgesellschaft mbH.
Copyright – WAGO GmbH & Co. KG – All rights reserved. The content and structure of the WAGO websites, catalogs, videos and other WAGO media are subject to copyright. Distribution or modification of the contents of these pages and videos is prohibited. Furthermore, the content may neither be copied nor made available to third parties for commercial purposes. Also subject to copyright are the images and videos that were made available to WAGO GmbH & Co. KG by third parties.