

# WAGO I/O System Compact

Compact Controller 100; 8DI 8DIO 2AI 2AIO 2NI/PT 2x RS485; 2x ETHER-NET, SD

751-9412

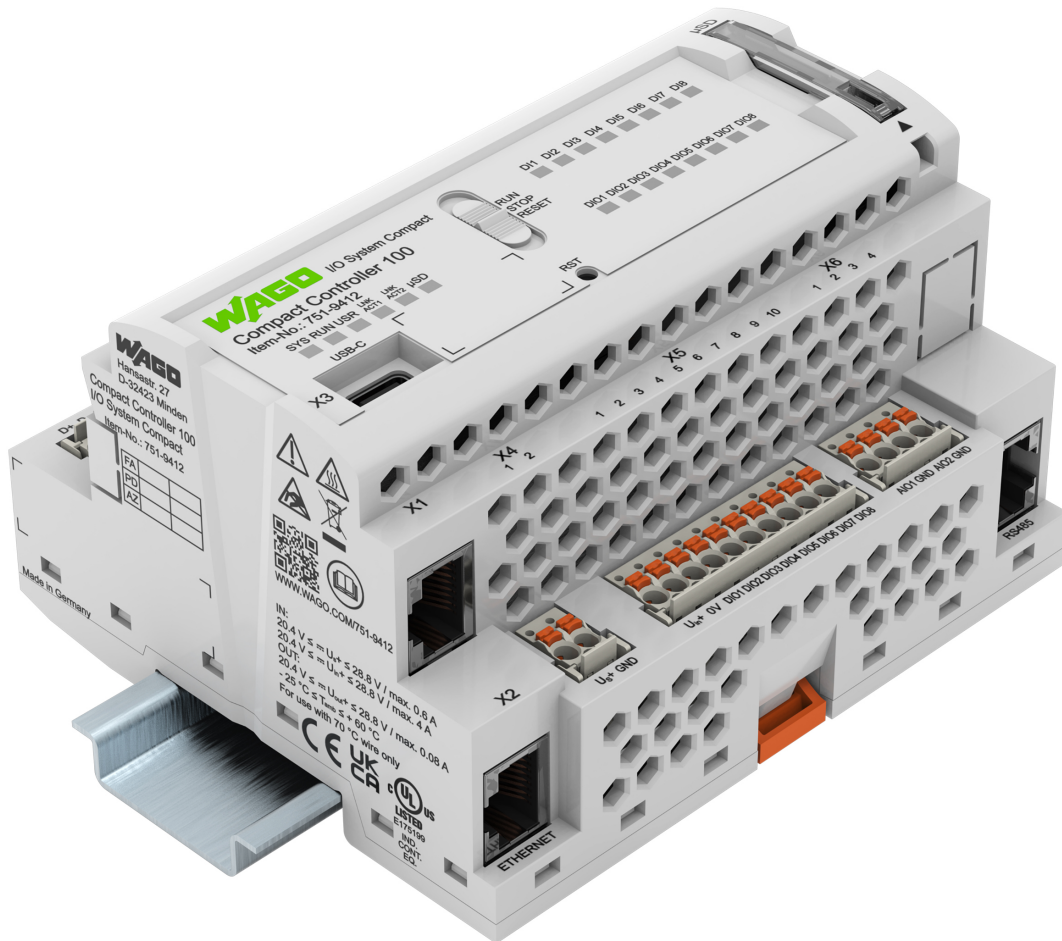

© 2026 WAGO GmbH & Co. KG  
All rights reserved.

**WAGO GmbH & Co. KG**

Hansastraße 27  
D - 32423 Minden

Phone: +49 571/887 – 0  
E-Mail: ✉ [info@wago.com](mailto:info@wago.com)  
Internet: 🌐 [www.wago.com](http://www.wago.com)

**Technical Support**

Phone: +49 571/887 – 44555  
E-Mail: ✉ [support@wago.com](mailto:support@wago.com)  
Internet: 🌐 [www.wago.com/support](http://www.wago.com/support)

Every conceivable measure has been taken to ensure the accuracy and completeness of this documentation. However, as errors can never be fully excluded, we always appreciate any information or suggestions for improving the documentation.

E-Mail: ✉ [documentation@wago.com](mailto:documentation@wago.com)

We wish to point out that the software and hardware terms as well as the trademarks of companies used and/or mentioned in the present documentation are generally protected by trademark or patent.

**WAGO is a registered trademark of WAGO Verwaltungsgesellschaft mbH.**

# Table of Contents

<b>1</b>	<b>Provisions</b>	<b>5</b>
1.1	Scope of Applicability	5
1.2	Intended Use	5
1.3	Typographical Conventions	7
1.4	Legal Information	8
<b>2</b>	<b>Safety</b>	<b>10</b>
2.1	General Safety Regulations	10
2.2	Electrical Safety	10
2.3	Mechanical Safety	11
2.4	Thermal Safety	11
2.5	Indirect Safety	11
<b>3</b>	<b>Overview</b>	<b>12</b>
<b>4</b>	<b>Properties</b>	<b>13</b>
4.1	View	13
4.2	Product Identification	14
4.2.1	Marking	14
4.2.2	Label	15
4.2.2.1	UII	16
4.2.3	Update Matrix	16
4.3	Connections	16
4.3.1	ETHERNET Interfaces - X1, X2	16
4.3.2	USB-C Service Interface - X3	17
4.3.3	Supply Voltage - X4	17
4.3.4	Digital Inputs - X12	17
4.3.5	Digital Inputs/Outputs - X5	18
4.3.6	Analog Inputs - X14	19
4.3.7	Analog Inputs/Outputs - X6	19
4.3.8	RTD Inputs - X13	20
4.3.9	Communication Interfaces	20
4.3.9.1	Communication Interface - X8	21
4.3.9.2	Communication Interface - X11	21
4.3.9.3	Bus Termination and Biasing	21
4.4	Memory Card Slot	22
4.5	Indicators	22
4.5.1	System LEDs	22
4.5.2	LNK ACT LEDs	22
4.5.3	Memory Card Slot LED	23
4.5.4	LEDs Status DI/DIO	23
4.6	Control Elements	23
4.6.1	Operating mode switch	23
4.6.2	Reset Button	23
4.7	DIN-Rail Contact	23
4.8	Circuit Diagram	24
<b>5</b>	<b>Planning</b>	<b>25</b>
5.1	Structure Guidelines	25
5.1.1	Safety Measures at the Installation Location	25
5.1.2	Mounting Position and Distances	25

5.1.3	DIN-Rail Characteristics .....	27
5.1.4	EMC Installation .....	27
5.1.5	Grounding.....	28
5.1.6	Data Security .....	28
5.1.7	Buffering .....	29
5.2	CODESYS V3 Compatibility .....	29
<b>6</b>	<b>Transport and Storage.....</b>	<b>30</b>
<b>7</b>	<b>Installation and Removal.....</b>	<b>31</b>
7.1	Mounting on the DIN-Rail.....	31
7.2	Removal from the DIN-Rail .....	31
7.3	Connectors .....	32
7.3.1	Delivery Condition.....	32
7.3.2	WAGO Pluggable Connectors .....	32
7.3.2.1	Pulling the Female Connector .....	32
7.3.2.1.1	Pulling with the Unlocking Tool.....	32
7.3.2.1.2	Pulling with Other Tools.....	33
7.3.2.2	Plugging the Female Connector.....	33
<b>8</b>	<b>Connection .....</b>	<b>35</b>
8.1	Connecting the Supply Voltage .....	35
<b>9</b>	<b>Diagnostics.....</b>	<b>36</b>
9.1	Diagnostics via Indicators.....	36
9.1.1	Diagnostics via LED Indicators: System .....	36
9.1.2	Diagnostics via Network LED Indicators .....	37
9.1.3	Diagnostics via LED Indicators: Memory Card Slot.....	38
9.1.4	Diagnostics via LED Indicators for Digital Inputs and Outputs.....	38
9.2	Diagnostics via WBM or WAGO Device Manager .....	38
<b>10</b>	<b>Decommissioning.....</b>	<b>39</b>
10.1	Disposal and Recycling.....	39
<b>11</b>	<b>Appendix .....</b>	<b>40</b>
11.1	Protected Rights .....	40
11.2	Technical Data, Approvals, Guidelines and Standards.....	41
11.2.1	Data Sheet 751-9401 .....	42

# 1 Provisions

## 1.1 Scope of Applicability

This document applies to:

**751-9412** (Compact Controller 100)

Compact Controller 100; 8DI 8DIO 2AI 2AIO 2NI/PT 2RS485; 2 × ETHERNET; SD; Secure

Version Firmware	01.02.03(03)
Product detail page	<a href="http://www.wago.com/751-9412">www.wago.com/751-9412</a>

The product must only be installed and operated in accordance with the operating instructions. Knowledge of the operating instructions is required for proper use. You can find all documents and information on the detailed product page.

### Note

#### Note applicable documents!

The complete operating instructions for the product consists of several, applicable documents. The product must only be installed and operated in accordance with the complete operating instructions. Knowledge of all applicable documents is required for proper use. You can find all documents and information on the product detail page.

#### Applicable documents

##### Function Manual Controller CC100 V2 Secure

- Cybersecurity
  - Threats
  - Vulnerabilities in Network Access
  - Vulnerabilities in Physical Access
  - Potential Targets
  - Hardening and Cybersecurity Capabilities
- Functions
- Commissioning
- Configuration
- Service

## 1.2 Intended Use

Controllers of WAGO's 751 Series I/O System Compact receive digital and analog signals from sensors and transmit them to the actuators or higher-level control systems. The signals can also be (pre-)processed with the controllers.

The product is an open type device and is designed for installation in an additional enclosure. In order to use it, it is connect to take protective measures suitable for the specific application.

- This product is intended for installation in automation technology systems.
- The product is designed for use in dry indoor rooms.

- Operation of the product is permitted in the industrial sector and in residential and commercial domains, including small businesses.
- Operation of the product in other application areas is only permitted when corresponding approvals and labeling are present.

### **Improper Use**

Improper use of the product is not permitted.

Improper use occurs in particular in the following cases:

- Non-observance of the intended use
- Use without protective measures in an environment in which moisture, salt water, salt spray mist, dust, corrosive fumes, gases, direct sunlight or ionizing radiation can occur
- Implementation of a Known Misuse
- Use of the product in areas with special risk that require continuous fault-free operation and in which failure of or operation of the product can result in an imminent risk to life, limb or health or cause serious damage to property or the environment (such as the operation of nuclear power plants, weapons systems, aircraft and motor vehicles)

### **Warranty and Liability**

The provisions of the latest WAGO General Terms and Conditions of Deliveries and Services (GTC) apply as well as the Software License Terms for Standard Software (SW-License) applicable to software products and software embedded in WAGO hardware products, both available at: [www.wago.com](http://www.wago.com).

In particular, the warranty is void when:

- The product is improperly used.
- The defect is based on (customer-)specific specifications (hardware and software configurations).
- Modifications of the hardware or software by the user or third parties were made that are not described in this documentation and are at least responsible for the occurrence of the defect.

Individual agreements always take precedence.

### **Obligations of the installer/operator**

Installers and operators bear responsibility for the safety of an installation or a system assembled with the product.

The installer/operator is responsible for the proper installation and the safety of the system. It must comply with the laws, standards, guidelines, local regulations, the state and the rules of technology applicable at the time of installation and must observe the guidelines and instructions described in the operating instructions. The installation requirements of the approvals must also be met.

In the event of non-compliance, operation of product within the scope of the approval is not permitted.

## 1.3 Typographical Conventions





### Number Notation

100	Decimals: Normal notation
0x64	Hexadecimals: C-notation
'100'	Binary: In single quotation marks
'0110.0100'	Nibbles separated by a period

### Text Markups

<i>italic</i>	Names of paths or files
<b>bold</b>	Menu items, entry or selection fields, emphasis
Code	Excerpts from program code
>	Selection of a menu point from a menu
"Value"	Value entries
[F5]	Identification of buttons or keys

### Links

	Link to a topic in a document
	Link to a separate document
	Link to a website
	Link to an email address
<a href="#">Glossary</a>	Link to a glossary entry

### Sequence of Action

- ✓ This symbol identifies a precondition.
- 1. Action step
- 2. Action step
  - ⇒ This symbol identifies an intermediate result.
- ➔ This symbol identifies the result of an action.
- Individual action step

### Lists

- Lists, first level
  - Lists, second level

### Figures

Figures in this documentation are for better understanding and may differ from the actual product design.

## Warning Messages

### **DANGER**

#### Type and source of hazard

Indicates an imminently hazardous situation which, if not avoided, will result in death or serious injury.

- Action step to reduce risk

### **WARNING**

#### Type and source of hazard

Indicates a potentially hazardous situation which, if not avoided, could result in death or serious injury.

- Action step to reduce risk

### **CAUTION**

#### Type and source of hazard

Indicates a potentially hazardous situation which, if not avoided, may result in minor or moderate injury.

- Action step to reduce risk

### **NOTICE**

#### Type and source of malfunction (property damage only)

Indicates a potentially hazardous situation which, if not avoided, may result in damage to property.

- Action step to reduce risk

## Information Notices

### **Note**

#### Information

Indicates information, clarifications, recommendations, referrals, etc.

## 1.4 Legal Information

### Intellectual property

The intellectual property of this document belongs to WAGO GmbH & Co. KG. The reproduction and distribution of its content (in whole or in part) is prohibited, unless otherwise provided by statutory provisions, written agreements or this document. In case of doubt, the written consent of WAGO GmbH & Co. KG must be obtained in advance.

Third-party products are always mentioned without any reference to patent rights. WAGO GmbH & Co. KG, or the manufacturer of third-party products, retains all rights regarding patent, utility model or design registration.

Third-party trademarks are referred to in the product documentation. The “®” and “™” symbols are omitted hereinafter. The trademarks are listed in the Appendix: [Protected Rights \[▶ 40\]](#).

### Subject to Change

The instructions, guidelines, standards, etc., in this manual correspond to state of the art at the time the documentation was created and are not subject to updating service. The installer and operator bear sole responsibility to ensure they are complied with in their currently applicable form. WAGO GmbH & Co. KG retains the right to carry out technical changes and improvements of the products and the data, specifications and illustrations of this manual. All claims for change or improvement of products that have already been delivered – excepting change or improvement performed under guarantee agreement – are excluded.

### Licenses

The product contains open-source software. The requisite license information is saved in the product. This information is also available under [www.wago.com](http://www.wago.com).

## 2 Safety



This section presents hazards that could occur if the product is used. Builders and operators must take all hazards into account when analyzing the risk of their installed systems. Measures to reduce the risk of hazards that are foreseeable from the manufacturer's point of view (i.e., without knowledge of the specific system built) are explained in the respective sections of this documentation (e.g., in "Planning").

Builders and operators must implement explained risk reduction measures and also take their own measures depending on the residual risk.

### 2.1 General Safety Regulations

- This documentation is part of the product. Therefore, retain the documentation during the entire service life of the product. Pass on the documentation to any subsequent user of the product. In addition, ensure that any supplement to this documentation is included, if necessary.
- The product must only be installed and put into operation by qualified electrical specialists per EN 50110-1/-2 and IEC 60364.
- Set up permissions management for authorized persons.
  - Physical access may only be made by authorized persons.
  - Digital access may only be made by authorized persons.
- Comply with the laws, standards, guidelines, local regulations and accepted technology standards and practices applicable at the time of installation.

### 2.2 Electrical Safety

- Hazardous electrical voltage can cause electric shock or burns! Always disconnect all power supplies from the product before mounting, installing, troubleshooting or performing maintenance.
- Make sure the product does not carry any voltage before starting work.

#### Power Supply

- For non-hazardous live voltages, use SELV/PELV power supplies in accordance with EN/UL/IEC 61010-1.
- Provide a suitable disconnect mechanism and overcurrent protection on the system side. The disconnect mechanism must be located near the product where it can be operated and be clearly associated with the product. The **OFF** position of the disconnect mechanism must be clearly marked.

#### Grounding/Protection/Fuses

- When handling the product, please ensure that environmental factors (personnel, work space and packaging) are properly equalized. Do not touch any conducting parts.
- Establish sufficient grounding. Make sure there is a flawless electrical connection between the DIN-rail and frame / additional enclosure.

#### Cables

- To minimize interference (e.g., by electromagnetic interference), maintain a spatial separation between control, signal and data lines and the power supply lines.
- Always design the connection cables for the maximum anticipated current load.

- High currents and the inherent heat generated by the product can cause additional heat generation at the clamping point. Plan for a correspondingly higher temperature range for the connecting cables, or reduce inherent heat by selecting larger conductor cross-sections.
- Only one conductor may be connected to each connection point (e.g., CAGE CLAMP® connection).

#### **Protection**

- When working on the system (e.g., during maintenance), protect the facility part in question from accidental or unauthorized restart.

### **2.3 Mechanical Safety**

- Before startup, please check the product for any damage that may have occurred during shipping. Do not put the product into operation in the event of mechanical damage.
- Do not open the product housing.

### **2.4 Thermal Safety**

- The surface of the housing heats up during operation. Under special conditions (e.g., in the event of a fault or increased surrounding air temperature), touching the product may cause burns. Allow the product to cool down before touching it.
- Cooling of the product must not be impaired. Ensure air can flow freely and that the minimum clearances from adjacent products/areas are maintained.
- The temperature inside the additional enclosure must not exceed the ambient temperature permitted for the mounted product.

### **2.5 Indirect Safety**

- Only use a dry or cloth or a clothed dampened with water to clean the product. Do not use cleaning agents, e.g., abrasive cleaners, alcohols or acetone.
- Do not use any contact spray for cleaning.
- The product is not resistant to materials with seeping and insulating properties, such as aerosols, silicones or triglycerides (found in some hand creams). If these substances occur in the environment of the product, install the product in an additional housing that is resistant to these substances as well.
- Only permit skilled personnel approved by WAGO to perform repair work.
- Replace any defective or damaged devices.
- Observe possible different technical specifications for mounting that does not correspond to the nominal mounting position.
- Only use accessories authorized by WAGO.

## 3 Overview

The controller is an automation device that can perform PLC control tasks. The controller is suitable for mounting on a DIN-rail and characterized by various interfaces.

The controller can be used for applications in mechanical and systems engineering, in the processing industry and in building technology.

The controller's features include integrated digital and analog inputs and outputs and a serial onboard interface per EIA-485/RS-485.

# 4 Properties

## 4.1 View

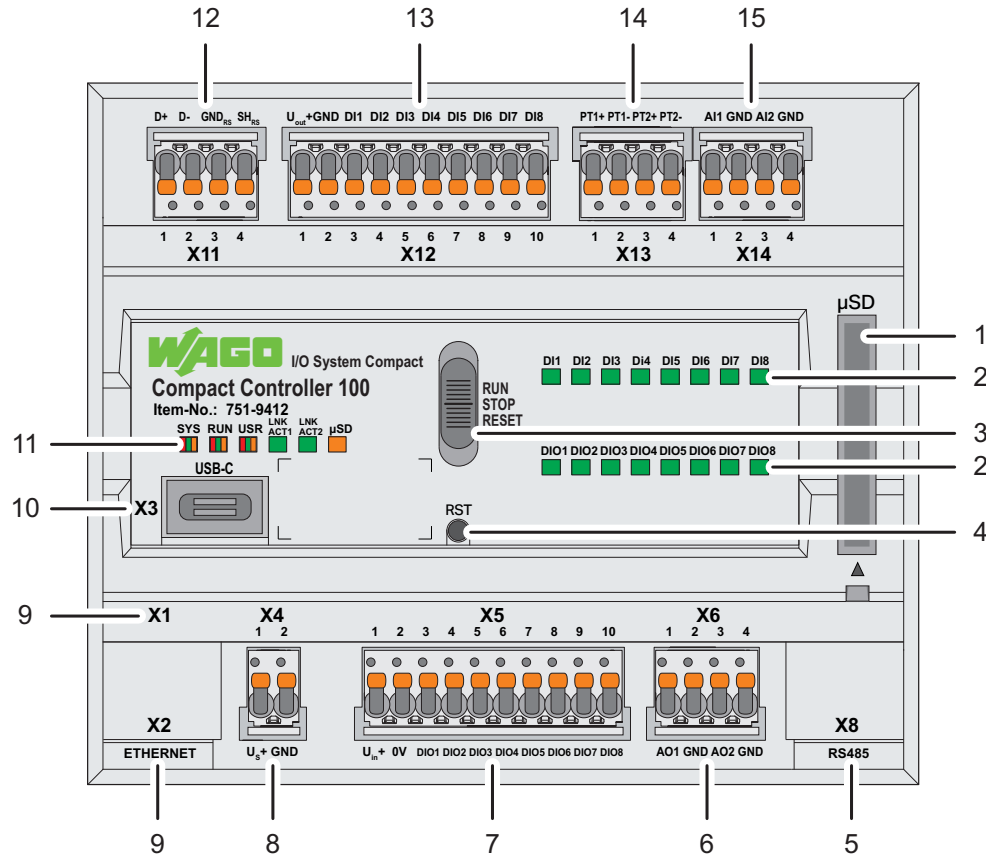

Figure 1: Ansicht

1	<a href="#">Memory Card Slot</a> [ <a href="#">&gt; 22</a> ]
2	<a href="#">LEDs Status DI/DIO</a> [ <a href="#">&gt; 23</a> ]
3	<a href="#">Operating mode switch</a> [ <a href="#">&gt; 23</a> ]
4	<a href="#">Reset Button</a> [ <a href="#">&gt; 23</a> ]
5	Communication Interface X8 <a href="#">Communication Interfaces</a> [ <a href="#">&gt; 20</a> ]
6	<a href="#">Analog Inputs/Outputs - X6</a> [ <a href="#">&gt; 19</a> ]
7	<a href="#">Digital Inputs/Outputs - X5</a> [ <a href="#">&gt; 18</a> ]
8	<a href="#">Supply Voltage - X4</a> [ <a href="#">&gt; 17</a> ]
9	<a href="#">ETHERNET Interfaces - X1, X2</a> [ <a href="#">&gt; 16</a> ]
10	<a href="#">USB-C Service Interface - X3</a> [ <a href="#">&gt; 17</a> ]
11	<a href="#">System LEDs</a> [ <a href="#">&gt; 22</a> ] <a href="#">LNK ACT LEDs</a> [ <a href="#">&gt; 22</a> ] <a href="#">Memory Card Slot LED</a> [ <a href="#">&gt; 23</a> ]
12	Communication Interface X11 <a href="#">Communication Interfaces</a> [ <a href="#">&gt; 20</a> ]
13	<a href="#">Digital Inputs - X12</a> [ <a href="#">&gt; 17</a> ]
14	<a href="#">RTD Inputs - X13</a> [ <a href="#">&gt; 20</a> ]
15	<a href="#">Analog Inputs - X14</a> [ <a href="#">&gt; 19</a> ]

## 4.2 Product Identification

### 4.2.1 Marking

The marking is located on the left side of the product.

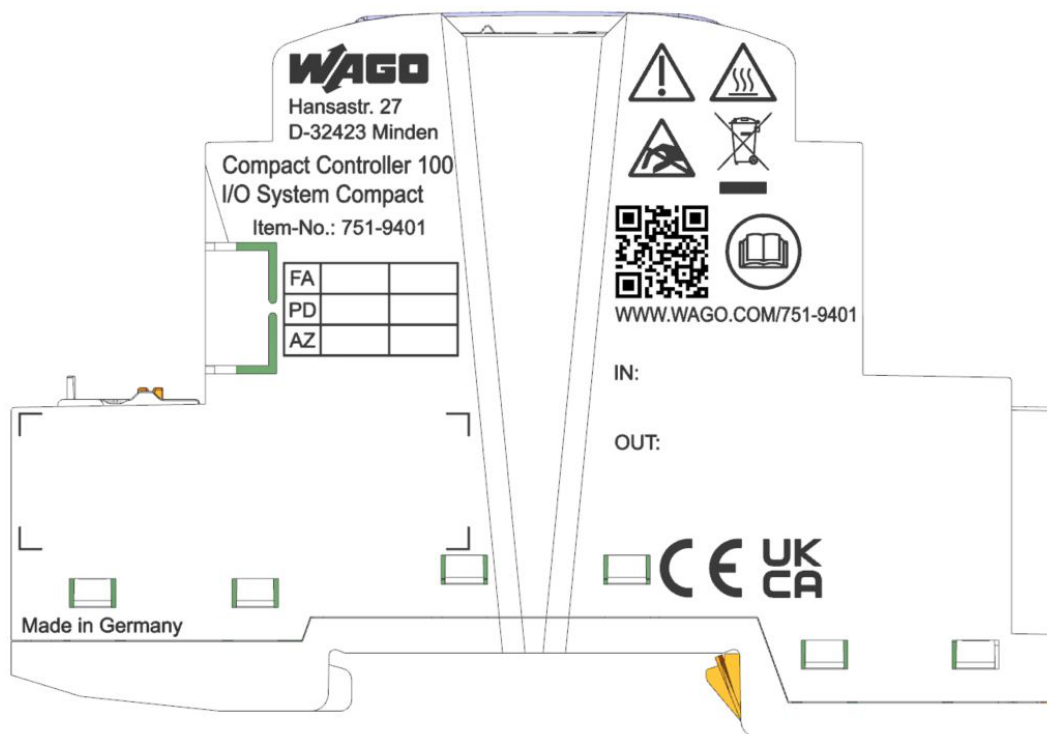









Figure 2: Marking (Example)

Table 1: Marking

Content	Description	
WAGO logo and address	WAGO GmbH & Co. KG	
Product information	Item number and product description	
Update matrix	<a href="#">Update Matrix</a> [ > 16 ]	
Label	Label	
	"Caution" exclamation icon	<b>Note:</b> Observe the product documentation! Applicable information and documents concerning the product exist which must be observed.
	"Hot surface" warning symbol	<b>Warnung:</b> Do not touch hot surfaces! The housing surface can become hot during operation. If the product has been used in high ambient temperatures, let it cool down before touching it.
	"ESD" mark	<b>Note:</b> Avoid electrostatic discharge! The products are equipped with electronic components that may be destroyed by electrostatic discharge when touched. Please following the safety precautions per DIN EN 61340-5-1/-3 to prevent electrostatic discharge.

Content	Description	
	"WEEE" mark	<p><b>Note:</b> Electrical and electronic equipment must not be disposed of with household waste!</p> <p>Electrical and electronic equipment contains materials and substances that can be harmful to the environment and health. Electrical and electronic equipment must be disposed of properly after use.</p> <p>For more information on this topic, see <a href="#">Disposal and Recycling [p. 39]</a>.</p>
		QR Code to the product detail page
	"Observe the product documentation!" symbol	Observe the product documentation! Applicable information and documents concerning the product exist which must be observed. You can find this on the product detail page via the QR code.
	CE mark	With the CE mark, WAGO declares that the product meets the applicable requirements as set out in Community harmonization legislation per EC Regulation 765/2008, which allows the product to carry this mark.
	UKCA	The UKCA (UK Conformity Assessed) mark declares that the conformity requirements for the UK market are met.
IN: 20.4 V ≤ U <sub>s</sub> + ≤ 28.8 V / max. 0.5 A 20.4 V ≤ U <sub>in</sub> + ≤ 28.8 V / max. 2 A		System supply Supply of the Digital Outouts
OUT: 20.4 V ≤ U <sub>out</sub> + ≤ 28.8 V / max. 0.2 A -25 °C ≤ T <sub>amb</sub> ≤ + 60 °C		Supply of the Digital Inputs Ambient temperature (operation)

### 4.2.2 Label

The label is located on the left side of the product.

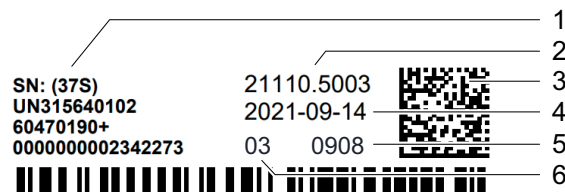

Figure 3: Label (Example)

Table 2: Etikett

1	Product identifier (UII)	
2	Control number	
3	Product identifier (UII) in the form of a Data Matrix code	
4	Date of manufacture (year-month-day)	
5	Production plant identifier	

6	Hardware revision number	
---	--------------------------	--

#### 4.2.2.1 UII

A UII (“**U**nique **I**tem **I**dentifier”) is provided for identification and traceability.

The 39-character UII is made up of several parts:

- It starts with three characters of the four-character data frame (per ISO/IEC 15481, possibly in parentheses)
- The 11-character manufacturer code assigned by an issuing agency in accordance with ISO/IEC 15459
- The eight-digit material number
- A single linking character, which is part of the data frame per ISO/IEC 15481
- The 16-digit “serial number”

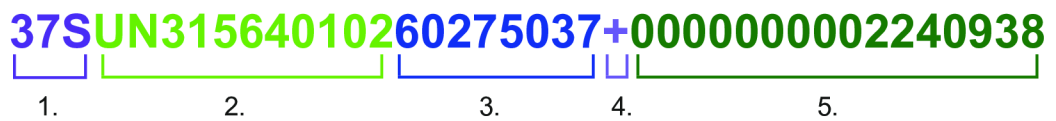

Figure 4: UII Structure (Example)

Table 3: Structure of the UII

Pos.	Number of Characters	Type of Identifier
1.	3	Data frame (part 1, possibly in parentheses)
2.	11	Manufacturer ID
3.	8	Material number
4.	1	Data frame (part 2)
5.	16	Serial number

#### 4.2.3 Update Matrix

In the event of a factory update, the updated production data is documented in the update matrix. The initial manufacturing information on the product housing remains unchanged.

Table 4: Update Matrix

<b>FA</b>	XXXXXXXXXX	Production order number, 10-digit
<b>PD</b>	WWYY	WW: production week YY: production year
<b>AZ</b>	FWHWFL	FW: firmware index HW: hardware index FL: firmware loader index

### 4.3 Connections

#### 4.3.1 ETHERNET Interfaces - X1, X2

The ETHERNET ports are for connecting to a LAN or the Internet for communication with the controller. A crossover cable or category 5e patch cable can be used.

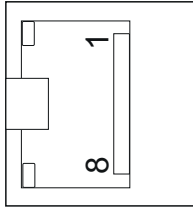

Figure 5: ETHERNET Interface Pin Assignment

Table 5: ETHERNET Interface Pin Assignment

Contact	Signal	Description
1	TD+	Transmit data +
2	TD-	Transmit data -
3	RD+	Receive data +
4	NC	Not assigned
5	NC	Not assigned
6	RD-	Receive data -
7	NC	Not assigned
8	NC	Not assigned
Housing	Shield	Shield

#### 4.3.2 USB-C Service Interface - X3

The USB service port is designed as a type C socket.

The service interface is used for communication with WAGO Ethernet Settings.

You can establish an IP connection via this interface for commissioning and service purposes.

#### 4.3.3 Supply Voltage - X4

The connection is made via a 2-pole picoMAX® Pluggable Connector with Push-in CAGE CLAMP®S technology.

Table 6: Pin Assignment Supply Voltage

Contact	Signal	Description
1	U <sub>s</sub> +	Supply voltage
2	GND	Ground

#### 4.3.4 Digital Inputs - X12

The controller has 8 digital input channels (24 VDC, type 3).

The input channels receive binary control signals from digital field devices (e.g., sensors, encoders, switches or proximity sensors).

The connection is made via a 10-pole picoMAX® Pluggable Connector with Push-in CAGE CLAMP®S technology.

The sensors are connected according to the following table.

Table 7: Digital Input Pin Assignments

Contact	Signal	Description
1	U <sub>out</sub> +	Supply voltage output (DI1 ... DI8)
2	GND	Ground
3	DI1	Digital input 1

Contact	Signal	Description
4	DI2	Digital input 2
5	DI3	Digital input 3
6	DI4	Digital input 4
7	DI5	Digital input 5
8	DI6	Digital input 6
9	DI7	Digital input 7
10	DI8	Digital input 8

The inputs provide high-side switching. If the 24 V potential for the system power (X12,  $U_{out+}$ ) is switched to an input connection, the signal status of the corresponding input channel is set to "high."

A green status LED for each channel indicates the signal status.

The meaning of the LED indicator is described in the section [🔗 Diagnostics via LED Indicators for Digital Inputs and Outputs \[▶ 38\]](#).

#### 4.3.5 Digital Inputs/Outputs - X5

The controller has 8 switchable digital input/output channels (DI: 24 VDC, type 3 / DO: 24 VDC, 0.5 A).

Input channels receive binary control signals from sensors, switches or proximity sensors in the field.

The output channels output binary control signals from the automation device to the connected actuators, e.g., magnetic valves, contactors, relays or other electrical loads.

Configuration is performed using CODESYS or the "WAGO Device Manager" tool.

The sensors and actuators are connected according to the following table.

The connection is made via a 10-pole picoMAX® Pluggable Connector with Push-in CAGE CLAMP®S technology.

Table 8: Digital Input/Output Pin Assignments

Contact	Signal	Description
1	$U_{in+}$	Supply voltage input (DIO1 ... DIO8)
2	0 V	Ground
3	DIO1	Digital input/output 1
4	DIO2	Digital input/output 2
5	DIO3	Digital input/output 3
6	DIO4	Digital input/output 4
7	DIO5	Digital input/output 5
8	DIO6	Digital input/output 6
9	DIO7	Digital input/output 7
10	DIO8	Digital input/output 8

The inputs provide high-side switching. If the 24 V potential for field power (X5,  $U_{in+}$ ) is switched to an input connection, the signal status for the corresponding input channel is set to "high."

The outputs provide high-side switching. If the signal status of an output channel is "high," the 24 V potential for the field power supply is switched to the corresponding output connection.

The specifications of the connections corresponding to EN 61010-2-201: DC circuit, general use

A green status LED for each channel indicates the signal status.

The meaning of the LED indicator is described in the section [🔗 Diagnostics via LED Indicators for Digital Inputs and Outputs \[▶ 38\]](#).

#### 4.3.6 Analog Inputs - X14

The controller has 2 analog input channels that can be configured channel by channel.

The following measurement ranges can be configured:

- 0 ... 10 V, default setting
- -10 ... +10 V
- 0 ... 20 mA
- 4 ... 20 mA
- 3.6 ... 21 mA

Configuration is performed using CODESYS or the "WAGO Device Manager" tool.

The sensors are connected according to the following table.

The connection is made via a 4-pole picoMAX® Pluggable Connector with Push-in CAGE CLAMP®S technology.

Table 9: Analog Input Pin Assignments

Contact	Signal	Description
1	AI1	Analog input 1
2	GND	Ground
3	AI2	Analog input 2
4	GND	Ground

The internal power supply powers the module.

The ground connections for both channels are at a common 0 V ground potential.

#### 4.3.7 Analog Inputs/Outputs - X6

The controller has 2 configurable analog input/output channels that can be switched channel by channel.

The following measurement ranges can be configured:

- Inputs
  - 0 ... 10 V, default setting
  - -10 ... +10 V
  - 0 ... 20 mA
  - 4 ... 20 mA
  - 3.6 ... 21 mA
- Outputs
  - 0 ... 10 V
  - -10 ... +10 V
  - -12 ... +12 V
  - 0 ... 20 mA
  - 0 ... 22 mA
  - 4 ... 20 mA

Configuration is performed using CODESYS or the "WAGO Device Manager" tool.

The sensors and actuators are connected according to the following table.

The connection is made via a 4-pole picoMAX® Pluggable Connector with Push-in CAGE CLAMP®S technology.

Table 10: Analog Inputs/Outputs Pin Assignments

Contact	Signal	Description
1	AIO1	Analog input/output 1
2	GND	Ground
3	AIO2	Analog input/output 2
4	GND	Ground

The internal power supply powers the module.

The ground connections for both channels are at a common 0 V ground potential.

#### 4.3.8 RTD Inputs - X13

The controller has 2 RTD input channels that can be configured channel by channel.

2-wire resistance sensors can be connected directly.

The following measurement ranges can be configured:

- Pt100 (–200 ... +850 °C)
- Pt200 (–200 ... +850 °C)
- Pt500 (–200 ... +850 °C)
- Pt1000 (–200 ... +850 °C), default setting
- Ni100 (–60 ... +250 °C)
- Ni120 (–80 ... +260 °C)
- Ni1000 (TK6180) (–60 ... +250 °C)
- Ni1000 (TK5000) (–60 ... +250 °C)
- Potentiometer 0 ... 1.2 kOhm
- Potentiometer 0 ... 5 kOhm

Configuration is performed using CODESYS or the “WAGO Device Manager” tool.

The sensors are connected according to the following table.

The connection is made via a 4-pole picoMAX® Pluggable Connector with Push-in CAGE CLAMP®S technology.

Table 11: Analog Temperature Sensor Pin Assignments

Contact	Signal	Description
1	PT1+	Analog temperature sensor 1
2	PT1–	
3	PT2+	Analog temperature sensor 2
4	PT2–	

The controller linearizes the measured resistance values and converts them into a numerical value proportional to the temperature or resistance of the selected sensor.

#### 4.3.9 Communication Interfaces

The communication interfaces integrated into the controller connect devices with an RS-485 interface.

The RS-485 interface guarantees a high level of interference immunity through differential transmission and electrically isolated signals.

The connection to the communication partner is made via connections D+, D-, GND<sub>RS</sub> and SH<sub>RS</sub>.

The shield connection is directly connected to the DIN-rail.

The interfaces operate in accordance with TIA/EIA 485.

The connected device can communicate directly via the controller used. The active communication channel works independently of the higher-level bus system in half-duplex mode at up to 250000 baud.

The X8 communication interface is designed as an RJ45 socket.

The X11 communication interface is designed as a picoMAX® Pluggable Connector.

#### 4.3.9.1 Communication Interface - X8

Table 12: Communication Interface X8 Pin Assignment

Contact	Signal	Description
1	---	Not assigned
2	---	Not assigned
3	---	Not assigned
4	D-	Transmit/receive data -
5	D+	Transmit/receive data +
6	---	Not assigned
7	+5V_RS	Supply
8	GND_RS	Ground

#### 4.3.9.2 Communication Interface - X11

The connection is made via a 4-pole picoMAX® Pluggable Connector with Push-in CAGE CLAMP®S technology.

Table 13: Communication Interface X11 Pin Assignment

Contact	Signal	Description
1	D+	Transmit/receive data +
2	D-	Transmit/receive data -
3	GND <sub>RS</sub>	Ground
4	SH <sub>RS</sub>	Shield

#### 4.3.9.3 Bus Termination and Biasing

To minimize reflections at the end of the line, the RS-485 line must be terminated at the end with a 120 Ω line terminator. The RS-485 line is already terminated in the Compact Controller 100 with a bus termination resistor (121 Ω). A bias network (pull-up and pull-down resistor) is also integrated in the Compact Controller 100 to keep the bus lines at a specified level when no other subscriber is active.

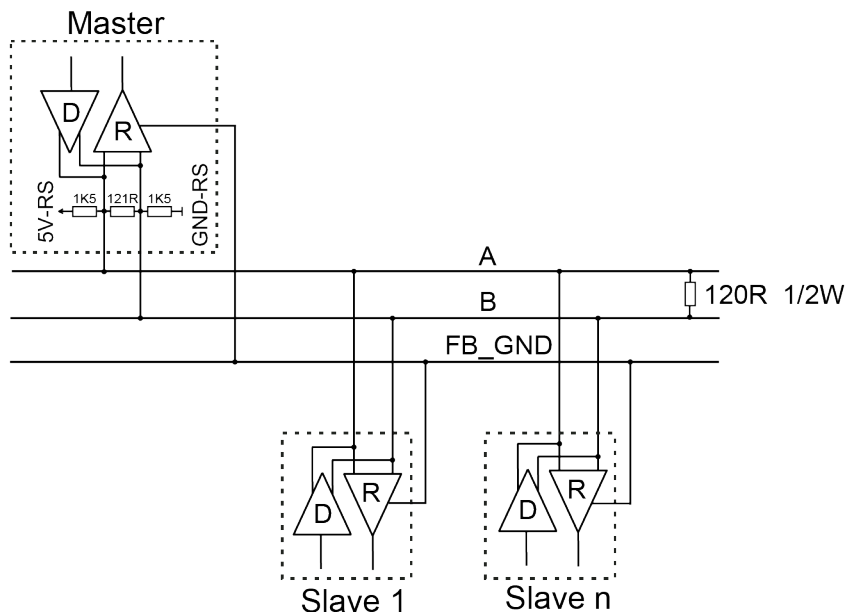

Figure 6: RS-485 Bus Termination

### 4.4 Memory Card Slot

The slot for the memory card is located on the front of the housing. A push-push mechanism is used to lock the memory card into the housing. The memory card is protected by a cover flap. The cover flap is sealable.

### 4.5 Indicators

#### 4.5.1 System LEDs

Table 14: System/Fieldbus LED Indicators

Designation	Color	Description
SYS	Red/green/orange/off	System status
RUN	Red/Green/Orange/Off	PLC program status
USR	Red/green/orange/off	User LED; programmable using function blocks from the WAGO libraries to control the LEDs

The meanings of the indicated states are described in [Diagnostics via LED Indicators: System](#) [▶ 36].

#### 4.5.2 LNK ACT LEDs

Table 15: LNK/ACT LED Indicators

Designation	Color	Description
LNK ACT 1 LNK ACT 2	Green/off	ETHERNET Connection Status/Data Exchange

The meanings of the indicated states are described in [Diagnostics via Network LED Indicators](#) [▶ 37].

### 4.5.3 Memory Card Slot LED

Table 16: Memory Card Slot LED Indicator

Designation	Color	Description
μSD	Orange/off	Memory card status

The meanings of the indicated states are described in [🔗 Diagnostics via LED Indicators: Memory Card Slot \[▶ 38\]](#).

### 4.5.4 LEDs Status DI/DIO

Table 17: DI/DIO LED indicator

Designation	Color	Description
DI1 ... DI8 DIO1 ... DIO8	Green/off	Status of Digital Inputs and Outputs

The meanings of the indicated states are described in [🔗 Diagnostics via LED Indicators for Digital Inputs and Outputs \[▶ 38\]](#).

## 4.6 Control Elements

### 4.6.1 Operating mode switch

Table 18: Operating mode switch

Pos.	Actuation	Function
RUN	Latching	<b>Normal operation</b> CODESYS V3 applications are running
STOP	Latching	<b>Stop</b> All CODESYS V3 applications have stopped
RESET	Spring-return	Warmstart Reset or Coldstart Reset (depending on how long it is actuated)

Other functions can also be triggered with the reset button.

### 4.6.2 Reset Button

The reset button is installed within a recess to prevent accidental operation. The button can be pressed with suitable object (e.g., a pen).

## 4.7 DIN-Rail Contact

The product transmits electromagnetic interference to the DIN-rail via DIN-rail contacts. The DIN-rail contacts are automatically connected when the product is snapped on to the DIN-rail.

### 4.8 Circuit Diagram

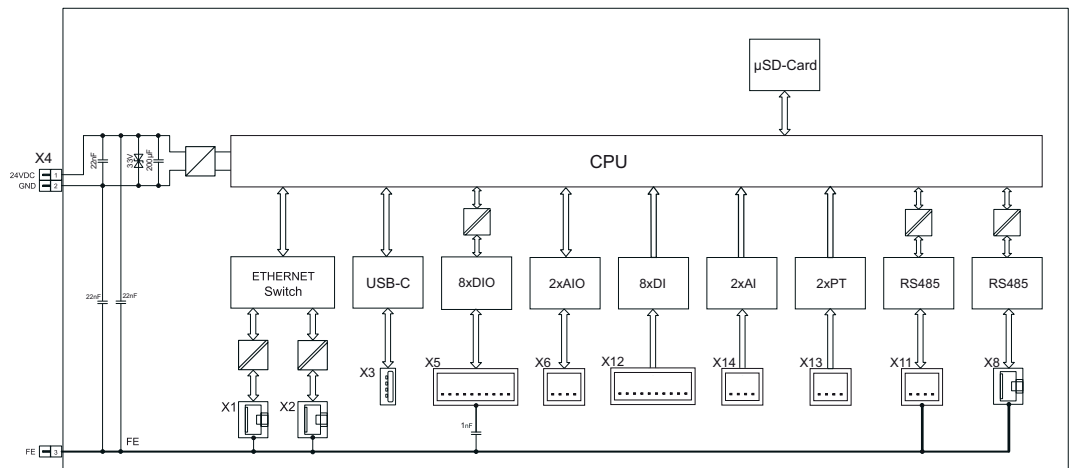

Figure 7: Circuit Diagram

# 5 Planning

## 5.1 Structure Guidelines

### 5.1.1 Safety Measures at the Installation Location

The product is an open type device.

It must only be installed in suitable enclosures, cabinets or electrical operating rooms that meet the following requirements at a minimum:

- Offer adequate protection against direct or indirect contact.
- Offer adequate protection against UV irradiation.
- Restrict access to authorized personnel and may only be opened with tools.
- Ensure the required pollution degree in the vicinity of the system.
- Prevent fire from spreading outside of the enclosure.
- Guarantee mechanical stability.

### 5.1.2 Mounting Position and Distances

All specifications and handling steps refer to the nominal mounting position. Deviating mounting positions affect, for example:

- The permissible ambient temperature

The following mounting positions are permitted:

Table 19: Mounting Positions and Permissible Ambient Temperatures

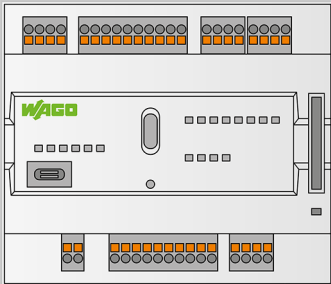
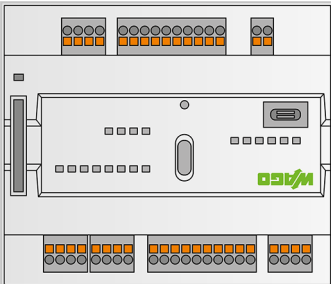
Mounting Position	Permissible Ambient Temperature
Horizontal (nominal mounting position) 	D = 10 mm: -25 ... +60 °C D = 0 mm: -25 ... +55 °C
Horizontal 180 ° 	D = 0 mm: -25 ... +55 °C

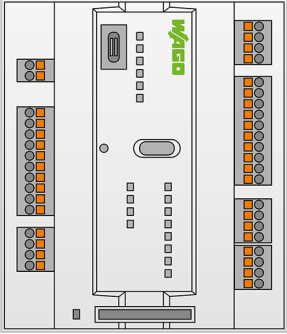
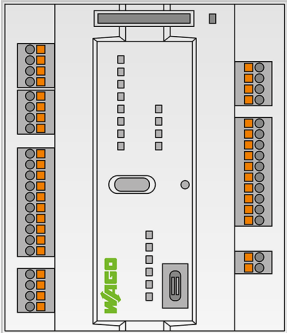
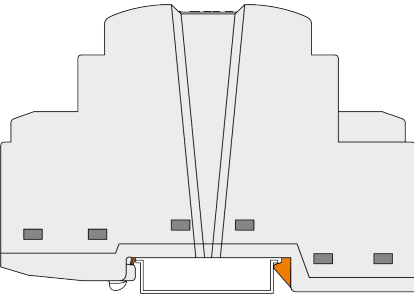
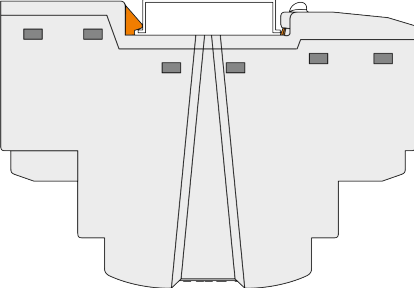
Mounting Position	Permissible Ambient Temperature
<p>Vertical</p> 	<p>D = 0 mm: -25 ... +55 °C</p>
<p>Vertical 180 °</p> 	<p>D = 0 mm: -25 ... +50 °C</p>
<p>Floor mounting</p> 	<p>D = 0 mm: -25 ... +50 °C</p>
<p>Overhead mounting</p> 	<p>D = 0 mm: -25 ... +50 °C</p>

Maintain the following distances from adjacent products, cable ducts and the sides of housings and frames for the setup.

The distance (D) from the power supply is 0 ... 10 mm, depending on the mounting position. For adjacent components on a DIN-rail, a distance below this minimum is possible if necessary.

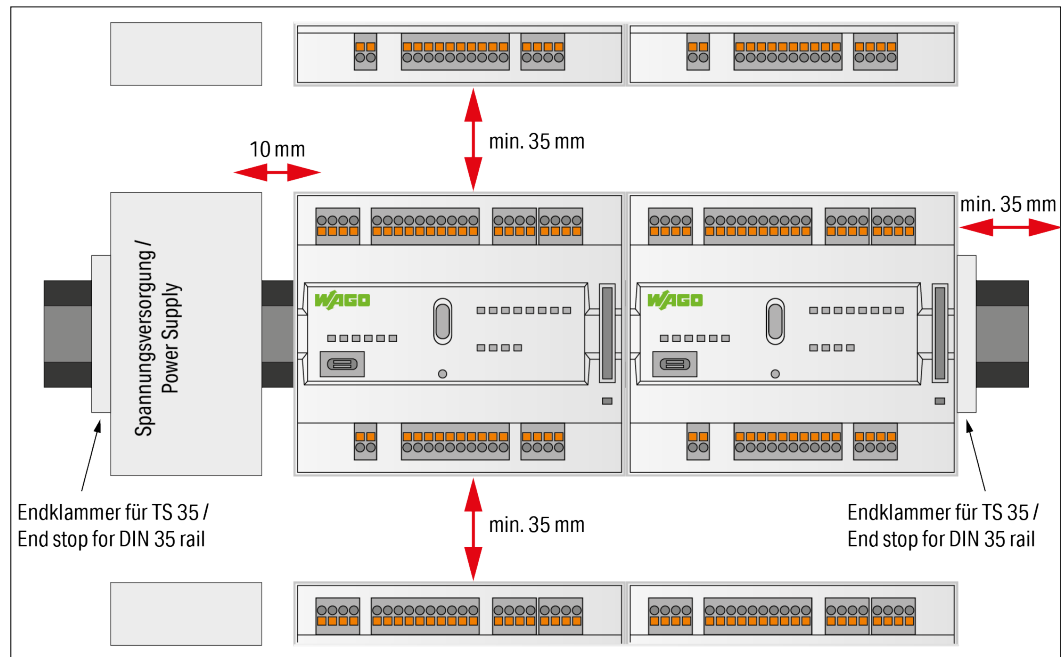

Figure 8: Distances

The distances leave space for heat dissipation and installation/wiring. The distances from cable ducts also prevent conducted electromagnetic interference from affecting operation.

If installation space is limited in the control cabinet or small installation distribution board, use angled network cables or patch cables for the X1 and X2 network connections if necessary.

### 5.1.3 DIN-Rail Characteristics

- The material must have high corrosion resistance.
- The DIN-rail geometry must not be altered.
- Prevent bending and twisting (torsion) e.g., by using sufficient attachment points.
- Use countersink-head screws, blind rivets, etc., to countersink the attachment points beneath the node structure.
- The component DIN-rail contact (CuSn6) must not form a galvanic element with the DIN-rail that is capable of generating a differential voltage of more than 0.5 V (saline solution of 0.3% at 20°C/68°F).

### 5.1.4 EMC Installation

- **Ground DIN-rails.**  
Ground the DIN-rails to divert electromagnetic interference.
- **Use shielded cables for data and signal lines.**  
Electromagnetic interference is reduced and signal quality increased. Measurement errors, data transmission faults and interference due to excessive voltage can be prevented!
- **Keep data and signal lines separate from interference sources.**  
Route data and signal lines separately from all power supply cables and other sources of high electromagnetic emissions (e.g., frequency converters or drives).
- **Connect the cable shielding with the ground potential.**  
Integrated shielding is mandatory to meet technical specifications regarding measurement accuracy. Establish the connection between the cable shielding and ground potential at the inlet of the cabinet or housing. This grounding allows induced interferences to dissipate and be kept away from devices in the cabinet or housing.

- **Improve shielding performance with a large contact area.**

A low-impedance connection between shielding and ground achieves better shielding performance. For this purpose, connect the shielding over a large surface area, e.g., using the WAGO Series 790 Shield Connection System. This is especially recommended for large-scale systems where equalizing or high impulse currents may occur.

### 5.1.5 Grounding

Snapping the product onto the grounded DIN-rail grounds it via the spring contacts on the underside.

### 5.1.6 Data Security

Professional planning and configuration are an important prerequisite for ensuring the confidentiality, availability and integrity of data.

#### Random Influences

Data transmission and processing can be disrupted by random influences, such as temporary electromagnetic disturbances. Proper setup can significantly reduce the likelihood of corruption or destruction of data.

For additional information see: [📖 EMC Installation \[▶ 27\]](#).

#### Deliberate Influences

#### Use in ETHERNET Areas

ETHERNET products are designed for use in local networks. Please note the following when using ETHERNET products in your system:

- Do not connect control components and control networks to an open network such as the Internet or an office network.  
WAGO recommends putting control components and control networks behind a firewall.
- In the control components, close all ports and services not required by your application to minimize the risk of cyber attacks and to enhance cybersecurity.  
Only open the ports and services for the duration of the commissioning/configuration.
- Limit physical and electronic access to all automation components to authorized personnel only.
- To reduce the risk of unauthorized access to your system, change the default passwords during initial commissioning.
- To reduce the risk of unauthorized access to your system, regularly change the passwords used.
- To verify that the measures taken meet your security requirements, regularly perform threat analyses.
- To restrict access to and control of individual products and networks, employ a "defense-in-depth" mechanism in your system's security configuration.

#### Additional documents

- [📄 White Paper Cybersecurity in Production Facilities](#)

All the documentation and information is available at: [🌐 www.wago.com](http://www.wago.com).

## Use of Cloud Services

### **i** Note

#### **Please note the risks of using cloud services!**

If you use third-party cloud services, sensitive data is transferred to the cloud service provider on your own responsibility. External access may result in manipulated data and/or unwanted control commands affecting the performance of your control system.

- Use encryption methods to protect your data.
- Observe the information provided by the Federal Office for Information Security – “Cloud: Risks and Security Tips.”
- Observe comparable publications of the responsible authorities of your country.

Additional information is available at: [www.bsi.bund.de](http://www.bsi.bund.de).

### 5.1.7 Buffering

To compensate for power interruptions per IEC 61131 (PS-1 or PS-2), external buffering is required.

Buffer capacity depends on the node configuration, which is why it is not possible to provide general information on the required capacity.

## 5.2 CODESYS V3 Compatibility

Table 20: Compatibility Overview

Device Description	Firmware *)	Compiler	Visualization Profile
6.3.1.xx	04.06.xx (28)	3.5.19.7	CODESYS Visualization 4.6.0.0

#### **\*) Notes on firmware versions:**

- Not every new firmware contains a new version of the runtime environment, which is why the compiler version and visualization profile may remain unchanged.
- As a general rule, the compatibility also extends to hotfix and patch versions of the firmware, assuming only the bugfix point of the firmware version is different (example: “FW:01.02.xx(03)”).

## 6 Transport and Storage

The original packaging offers optimal protection during transport and storage.

- Store the product in suitable packaging, preferably the original packaging.
- Only transport the product in suitable containers/packaging.
- Make sure the product contacts are not contaminated or damaged during packing or unpacking.
- Observe the specified ambient climatic conditions for transport and storage.

# 7 Installation and Removal

## 7.1 Mounting on the DIN-Rail

Mount the product per EN 60715 by snapping it onto the DIN-rail without tools:

1. Tilt the product slightly.
2. Place the product, with the DIN-rail guide, on the top edge of the DIN-rail.

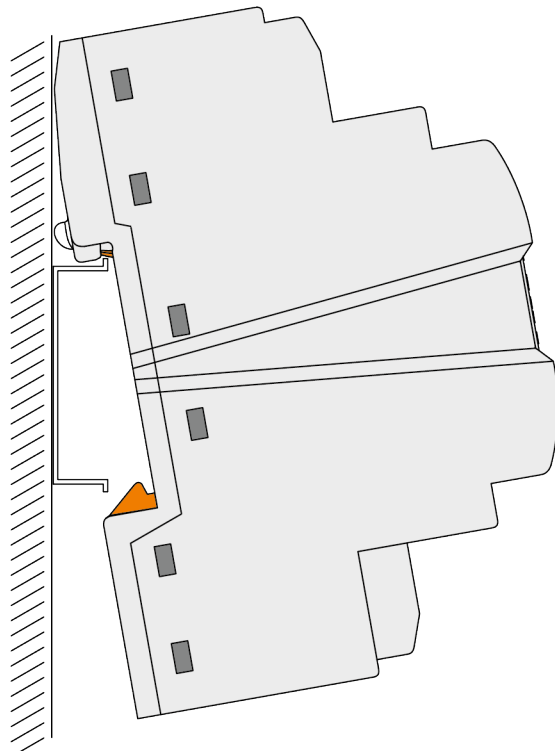

Figure 9: Inserting Controller

3. Press the product onto the DIN-rail.
4. Push down until the product audibly snaps into place.
5. Gently shake the product to ensure that it is correctly locked into place.
6. To ensure secure fastening on the DIN-rail, fit end stops on either side of the product (with a block arrangement: on either side of the products).

## 7.2 Removal from the DIN-Rail

1. To remove, pull the DIN-rail release tab down.  
Use a screwdriver or operating tool for this purpose.  
⇒ The product is now unlocked.
2. Tilt the product forward and unhook it from the DIN-rail.

## 7.3 Connectors

### 7.3.1 Delivery Condition

When the product is delivered, the female connectors are included but not plugged in.

### 7.3.2 WAGO Pluggable Connectors

#### 7.3.2.1 Pulling the Female Connector

WAGO recommends using the unlocking tool for WAGO 2092 Series Pluggable Connectors (referred to in the following text as the "unlocking tool"). You can find more information on the unlocking tool in [www.wago.com/2092-1630](http://www.wago.com/2092-1630).

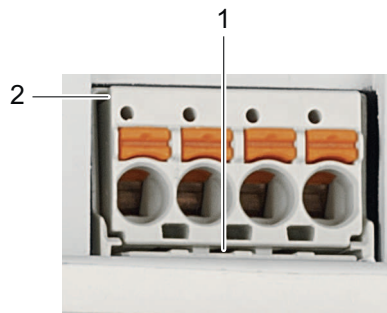

Figure 10: Removing the Female Connector without Wiring (Application Example)

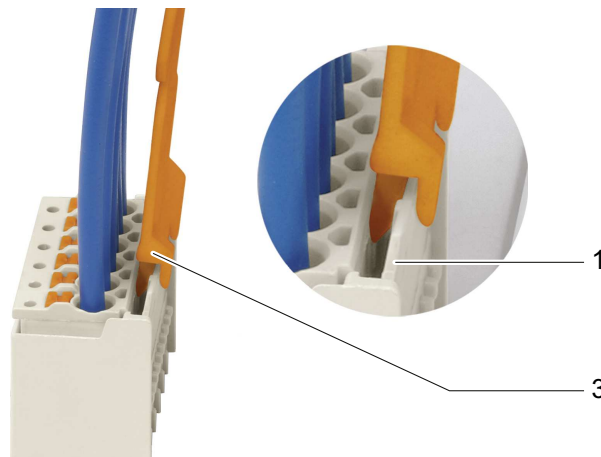

Figure 11: Removing the Female Connector with Wiring (Application Example)

Position	Description
1	Male locking latch
2	Overhanging edge of the female connector
3	Unlocking tool

#### 7.3.2.1.1 Pulling with the Unlocking Tool

Proceed as follows to remove the female connector using the unlocking tool:

##### Removing the Female Connector without Wiring

1. Place the unlocking tool (3) onto the locking latch (1).
2. Insert the unlocking tool until it hits the stop.
  - ⇒ The wedge opens the locking latch, leasing the locking mechanism.

3. Grasp the underside of the overhanging edge of the female connector (2).
4. Pull out the female connector.

#### Removing the Female Connector with Wiring

1. Place the unlocking tool (3) onto the locking latch (1).
2. Insert the unlocking tool until it hits the stop.
  - ⇒ The wedge opens the locking latch, leasing the locking mechanism.
3. Pull on the unlocking tool together with the conductors to remove the female connector.

#### 7.3.2.1.2 Pulling with Other Tools

If you do not have an unlocking tool available, you can also remove the female connector with a WAGO operating tool.

#### Pulling the Female Connector

##### **WARNING**

#### **Do not insert the operating tool into the ventilation slots!**

Components inside the product may be damaged if the blade of the operating tool enters the ventilation slots. This may lead to serious damage with a risk of injury caused by malfunction, overheating or electric shock!

- When using the operating tool, make sure it is positioned correctly between the locking latch and the female connector!

##### **NOTICE**

#### **Do not pull on the conductors when using an operating tool!**

Pulling on the conductors can loosen the contact.

1. Do **not** pull on the conductors!
2. Grasp the underside of the overhanging edge of the female connector to pull it out.

1. Use the operating tool to push the locking tab (1) away from the female connector.
2. Grasp the underside of the overhanging edge of the female connector (2).
3. Pull out the female connector.

#### 7.3.2.2 Plugging the Female Connector

##### **DANGER**

#### **Be sure to use the correct slot on the female connector!**

Mismatching the input female connector into the output connector may lead to a hazardous voltage of 230 V on the output side.

- Make sure the female connector is properly mated to the correct slot!

Proceed as follows to plug the female connector into the corresponding male header:

1. Insert the female connector into the corresponding male header.
2. Push the female connector into the male header until the female connector snaps into position with an audible click.
3. When inserting with wiring: Check that the female connector is seated securely by gently pulling on the wires.

# 8 Connection

## 8.1 Connecting the Supply Voltage

- Connect the power supply to connector X4, pin 1 (US+) and pin 2 (GND), as well as to connector X5, pin 1 (Uin+) and pin 2 (0V). Use the connectors included in the delivery (female connector with item number 2091-1122 resp. female connector with item number 2091-1130).

Switch on the power supply for connector X5 before or at least simultaneously with the power supply for connector X4!

# 9 Diagnostics

## 9.1 Diagnostics via Indicators

### 9.1.1 Diagnostics via LED Indicators: System

The "SYS" LED indicates the following diagnostics:

Table 21: "SYS" Diagnostic LED

Status	Explanation	Remedy
Green, steady	Ready for operation; system booted without error.	---
Green, flashing	System is booting; boot process is running.	<ul style="list-style-type: none"> <li>Wait for the boot process to finish</li> </ul>
Orange	Boot loader is active.	<ul style="list-style-type: none"> <li>Wait for the boot process to finish</li> </ul>
Orange, flashing	DRM license evaluation is running.	<ol style="list-style-type: none"> <li>Activate the associated licenses before the trial period expires.</li> <li>Alternatively, remove the libraries or device functions from your application.</li> </ol> <p>The device has unrestricted functionality until the evaluation period ends. Once the evaluation period ends, it is no longer possible to start the device without activating the corresponding licenses.</p>
Orange/green, flashing	Factory reset started.	<ul style="list-style-type: none"> <li>Wait for the reset process to finish.</li> </ul>
Red/green flashing	Firmware update mode	<ul style="list-style-type: none"> <li>Wait for the update process to finish.</li> </ul>
Red, steady	DRM license has expired.	<ol style="list-style-type: none"> <li>Activate the associated licenses immediately.</li> <li>Alternatively, remove the libraries or device functions from your application.</li> </ol>
Red, steady	Factory reset failed.	???

The "RUN" LED displays the PLC program status with the following diagnostics:

Table 22: "RUN" Diagnostic LED

Status	Explanation	Remedy
Green	Applications loaded and all have status "RUN"	---
Green, flashing	No application and no boot project loaded	<ul style="list-style-type: none"> <li>Load an application or boot project.</li> </ul>
Orange	Applications loaded and all have status "STOP"	<ul style="list-style-type: none"> <li>Set the mode selector switch to "RUN" to start the application.</li> </ul>

Status	Explanation	Remedy
	Runtime system in debug state (breakpoint, step mode, individual cycle)	<ol style="list-style-type: none"> <li>1. Resume the application in the associated IDE with step mode or start. If applicable, remove breakpoints.</li> <li>2. If the connection has been interrupted, set the operating mode switch to "STOP" and then back to "RUN" to allow the application to continue.</li> </ol>
Green/red, flashing	At least one application with status "RUN" and status "STOP"	<ul style="list-style-type: none"> <li>Start the stopped application.</li> </ul>
Red, one brief off pulse	Warm start reset completed	---
Red, one longer off pulse	Cold start reset completed	---
Red, flashing	At least one application with status "STOP" after exception (e.g., memory access error)	<ol style="list-style-type: none"> <li>1. Restart the application by resetting via the mode selector switch or in the associated IDE.</li> <li>2. If the application cannot be started, restart the controller.</li> <li>3. Contact WAGO Support if the error occurs again.</li> </ol>
Orange/green, flashing	Load above threshold value 1	<ul style="list-style-type: none"> <li>Try to reduce the load on the system:</li> <li>Change the CODESYS program.</li> <li>Terminate any fieldbus communication that is not essential or re-configure the fieldbuses.</li> <li>Remove any non-critical tasks from the RT area.</li> <li>Select a longer cycle time for IEC tasks.</li> </ul>
Off	No runtime system loaded	<ul style="list-style-type: none"> <li>Activate a runtime system, e.g., via the WBM.</li> </ul>

The "USR" LED displays the following diagnostics:

Table 23: "USR" Diagnostics LED

Status	Explanation	Remedy
red/green/orange	Programmable status from the user program.	---

### 9.1.2 Diagnostics via Network LED Indicators

The "LNK|ACT" LED displays the network connection status with the following diagnostics:

Table 24: LNK ACT Diagnostic LED

Status	Explanation	Remedy
Off	No network communication.	<ul style="list-style-type: none"> <li>If necessary, check the network connections and network settings.</li> </ul>
Green	Existing connection to physical network	---
Flashing green	Network communication occurring.	---

### 9.1.3 Diagnostics via LED Indicators: Memory Card Slot

The LED for the memory card slot displays the memory card status with the following diagnostics:

Table 25: Memory Card Slot Diagnostic LED

Status	Explanation	Remedy
Off	No read or write access to the memory card	---
Flashing yellow	Read or write access to the memory card	---
Yellow, steady	Read or write access to the memory card	---

### 9.1.4 Diagnostics via LED Indicators for Digital Inputs and Outputs

The "DI<n>" LEDs display the following diagnostics:

Table 26: Diagnostics LEDs DI<n>

Status	Explanation	Remedy
Off	Digital input <n> is at low potential.	---
Green	Digital input <n> is at high potential.	---

The "DIO<n>" LEDs display the following diagnostics:

Table 27: Diagnostics LEDs DIO<n>

Status	Explanation	Remedy
Off	Digital input/output <n> is at low potential.	---
Green	Digital input/output <n> is at high potential.	---

## 9.2 Diagnostics via WBM or WAGO Device Manager

Diagnostics can also be performed via the WBM integrated into the device or via the WAGO Device Manager software.

You can find additional information in the function manual or the WAGO Device Manager instructions.

# 10 Decommissioning

## 10.1 Disposal and Recycling



### WEEE Mark

Electrical and electronic equipment may not be disposed of with household waste. This also applies to products without this mark.

Electrical and electronic equipment contain materials and substances that can be harmful to the environment and health. Electrical and electronic equipment must be disposed of properly after use. Environmentally friendly disposal benefits health, protects the environment from harmful substances in electrical and electronic equipment and enables sustainable and efficient use of resources.

- Observe the national and local regulations for the disposal of electrical and electronic equipment, lithium-ion batteries, lead–acid batteries and packaging.
- Clear any data stored on electrical and electronic equipment.
- Remove lithium-ion batteries, lead–acid batteries or memory cards that are added to the electrical and electronic equipment.
- Wear appropriate personal protective equipment when removing the lithium-ion batteries/lead–acid batteries.
- Dispose of the removed lithium-ion batteries/lead–acid batteries according to your local waste regulations (e. g. collection boxes at the retail or local collection points).
- Have electrical and electronic equipment sent to a local collection point.
- Dispose of all types of packaging to ensure a high level of recovery, reuse and recycling.
- Transport packages from the B2B area can be taken back free of charge via a return system in accordance with the Packaging Act. Please contact our service provider Interseroh directly. The corresponding certificate can be found at: [↗ corporate-certificates](#).
- Throughout Europe, Directives 2006/66/EC, 94/62/EC and 2012/19/EU (WEEE) apply. National directives and laws may differ.

# 11 Appendix

## 11.1 Protected Rights

- Adobe® and Acrobat® are registered trademarks of Adobe Systems Inc.
- Android™ is a trademark of Google LLC.
- Apple, the Apple logo, iPhone, iPad and iPod touch are registered trademarks of Apple Inc. registered in the USA and other countries. "App Store" is a service mark of Apple Inc.
- AS-Interface® is a registered trademark of the AS-International Association e.V.
- BACnet® is a registered trademark of the American Society of Heating, Refrigerating and Air Conditioning Engineers, Inc. (ASHRAE).
- *Bluetooth*® is a registered trademark of Bluetooth SIG, Inc.
- CiA® and CANopen® are registered trademarks of CAN in AUTOMATION – International Users and manufacturers Group e.V.
- CODESYS is a registered trademark of CODESYS Development GmbH.
- DeviceNet® is a registered trademark of the Open DeviceNet Vendor Association, Inc (ODVA).
- DALI is a registered trademark of the Digital Illumination Interface Alliance (DiiA).
- Docker® and the Docker® logo are trademarks or registered trademarks of Docker, Inc. in the USA and/or other countries. Docker, Inc. and other parties may also have trademark rights to other terms used herein.
- EtherCAT® is a registered trademark and patented technology licensed by Beckhoff Automation GmbH, Germany.
- ETHERNET/IP™ is a registered trademark of the Open DeviceNet Vendor Association, Inc (ODVA).
- EnOcean® is a registered trademark of EnOcean GmbH.
- *flexROOM*® is a registered trademark of WAGO Verwaltungsgesellschaft mbH.
- Google Play™ is a registered trademark of Google Inc.
- IO-Link is a registered trademark of PROFIBUS Nutzerorganisation e.V.
- KNX® is a registered trademark of the KNX Association cvba.
- Linux® is a registered trademark of Linus Torvalds.
- LON® is a registered trademark of the Echelon Corporation.
- Modbus® is a registered trademark of Schneider Electric, licensed for Modbus Organization, Inc.
- OPC UA is a registered trademark of the OPC Foundation.
- PROFIBUS® is a registered trademark of the PROFIBUS Nutzerorganisation e.V. (PNO).
- PROFINET® is a registered trademark of the PROFIBUS Nutzerorganisation e.V. (PNO).
- QR Code is a registered trademark of DENSO WAVE INCORPORATED.
- Subversion® is a trademark of the Apache Software Foundation.
- Windows® is a registered trademark of Microsoft Corporation.

## 11.2 Technical Data, Approvals, Guidelines and Standards

### Note

#### Subject to changes!

Please also observe the further product documentation! You can generate the current datasheet at any time at: [www.wago.com](http://www.wago.com) /<item number>.

#### See also

 Data Sheet 751-9401 [► 42]

# Data Sheet | Item Number: 751-9412

Compact Controller 100; 8DI 8DIO 2AI 2AIO 2NI/PT 2RS485; 2 x ETHERNET; SD; Secure



<https://www.wago.com/751-9412>

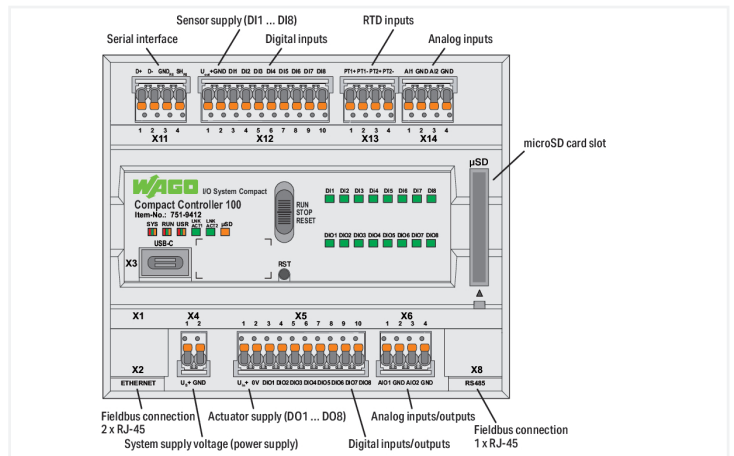
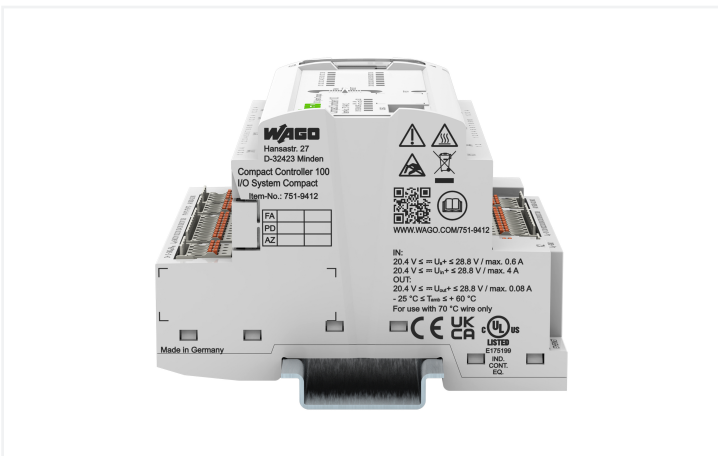
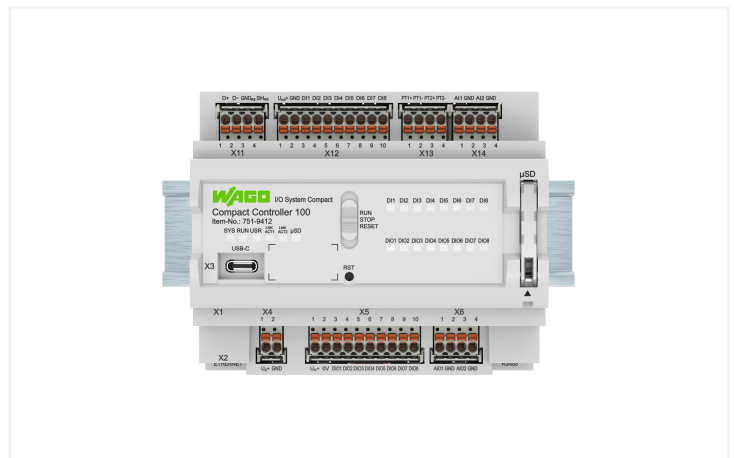
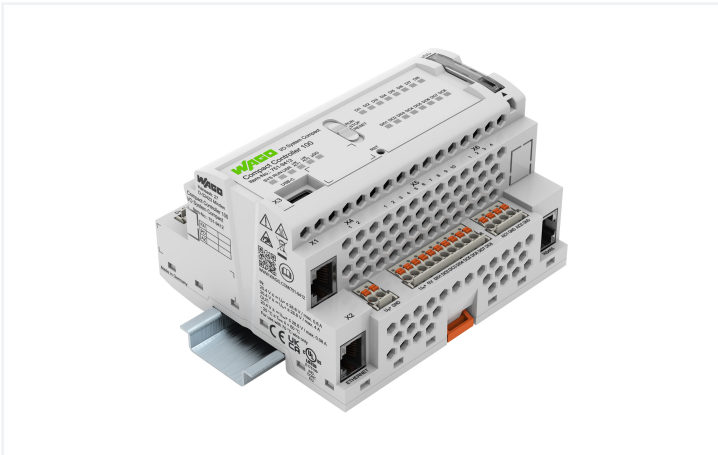

Technical data	
Communications	Modbus (TCP) Modbus RTU OPC UA Server/Client RS-485 interface MQTT (via IloT library) SNMP (via IloT library) Telecontrol protocols, (not part of IEC62443-4-2 certification), <b>requires an additional license</b>
ETHERNET protocols	DHCP DNS HTTPS SSH WDA OAuth2 LDAP IPsec
Visualization	Web-Visu
Operating system	Linux (Yocto distribution) with PREEMPT_RT
CPU	2 x Cortex A7; 650 MHz
Programming languages per IEC 61131-3	Instruction List (IL) Ladder Diagram (LD) Continuous Function Chart (CFC) Structured Text (ST) Sequential Function Chart (SFC)
Programming environment	CODESYS V3.5  CODESYS licenses included: <ul style="list-style-type: none"> <li>• Control Basic M</li> <li>• Communication S/M 2048 Tags</li> <li>• Visualization S 128 data points</li> <li>• IloT Libraries</li> </ul>
Configuration options	CODESYS V3.5 Web-Based Management WAGO Device Manager
Transmission rate	10/100 Mbit/s
Transmission medium (communication/fieldbus)	Twisted pair S-UTP; 100 Ω; Cat. 5; 100 m maximum cable length
Main memory (RAM)	512 MB
Internal memory (flash)	4096 MB
Non-volatile hardware memory	128 KB
Program memory	32 MB
Data memory	128 MB
Non-volatile software memory	128 KB
Type of memory card	microSD up to 32 GB (all guaranteed properties only valid with WAGO's memory card)
Memory Card Slot	Push-push mechanism
Indicators	LED (SYS, RUN), red/green: System status; LED (USR), red/green: User-programmable status (accessible via CODESYS library); LED (μSD), orange: microSD card status; LED (LNK/ACT), green: Network connection status via ports 1 ... 2; LED (DI1 ... 8), green: Status of inputs; LED (DO1 ... 8) green: Status of inputs and outputs
Control Elements	Operating mode switch (RUN, STOP, RESET); reset button
Interfaces (USB)	1 x USB, Typ C, Device-Mode
Supply voltage (system)	24 VDC (-15 ... +20 %); Via wiring interface ( <i>picoMAX</i> ® 3.5; Push-in CAGE CLAMP® connection)
Current consumption (system) max.	600 mA
Supply voltage (field)	24 VDC (-15 ... +20 %); Via wiring interface ( <i>picoMAX</i> ® 3.5; Push-in CAGE CLAMP® connection)
Field current consumption max. (digital outputs) $U_{in+}$	4000 mA
Isolation	1250 V (DC 1 min., between system and field level (digital outputs))

## Technical Data (Inputs/Outputs)

### Digital inputs/outputs

Number of configurable digital inputs/ outputs	8
Signal type	Voltage
Output current (per channel)	500 mA (DC)
Input characteristic	Type 3 (per EN 61131-2)

### Analog inputs/outputs

Number of analog inputs/outputs (configurable)	2
Resolution of analog inputs	16 bits
Input signal (current)	0 ... 20 mA 4 ... 20 mA 3.6 ... 21 mA
Input signal (voltage)	0 ... 10 V ±10 V
Resolution of analog outputs	12 bits
Output signal (current)	0 ... 20 mA 4 ... 20 mA 0 ... 22 mA
Output signal (voltage)	0 ... 10 V ±12 V ±10 V
Load impedance (voltage output)	≥ 1 kΩ
Load impedance (current output)	≤ 500 Ω

### RTD inputs

Number of measurement inputs	2
Sensor types	Pt100 (-200 ... +850 °C); Pt200 (-200 ... +850 °C); Pt500 (-200 ... +850 °C); Pt1000 (-200 ... +850 °C); Ni100 (-60 ... +250 °C); Ni1000, TK6180 (-60 ... +250 °C); Ni1000, TK5000 (-60 ... +250 °C); Ni120 (-80 ... +260 °C); Potentiometer 0 Ohm ... 1.2 kOhm; Potentiometer 0 Ohm ... 4 kOhm

## Connection Data

Connection technology: communication/fieldbus	Modbus (TCP): 2 x RJ-45; RS-485 interface: 1 x RJ-45; RS-485 interface: 1 x Female connector, 4-pole; Push-in CAGE CLAMP®
Connection technology: system supply	1 x Female connector, 2-pole; Push-in CAGE CLAMP®
Connection technology: field supply	2 x Female connector, 10-pole; Push-in CAGE CLAMP®
Connectable conductor materials	Copper
Solid conductor	0.2 ... 1.5 mm <sup>2</sup> / 24 ... 14 AWG
Fine-stranded conductor	0.2 ... 1.5 mm <sup>2</sup> / 24 ... 14 AWG
Strip length	8 ... 9 mm / 0.31 ... 0.35 inches

### Digital inputs

Number of digital inputs	8
Input characteristic	Type 3 (per EN 61131-2)

### Analog inputs

Number of analog inputs	2
Resolution of analog inputs	16 bits
Input signal (current)	0 ... 20 mA 4 ... 20 mA 3.6 ... 21 mA
Input signal (voltage)	0 ... 10 V ±10 V

### Physical data

Width	108 mm / 4.252 inches
Height	90 mm / 3.543 inches
Depth from upper-edge of DIN-rail	55 mm / 2.165 inches

### Mechanical data

Mounting type	DIN-35 rail
---------------	-------------

### Material data

Housing material	Polycarbonate, polyamid
Fire load	0 MJ
Weight	205 g
Conformity marking	CE; UKCA

### Environmental requirements

Ambient temperature (operation)	-25 ... +60 °C
Ambient temperature (storage)	-25 ... +80 °C
Protection type	IP20
Pollution degree	2 per IEC 61131-2
Operating altitude	0 ... 2000 m / 0 ... 6562 ft
Mounting position	any
Relative humidity (without condensation)	95 %
Vibration resistance	1g per IEC 60068-2-6
Shock resistance	15g per IEC 60068-2-27
EMC immunity to interference	per EN 61000-6-2
EMC emission of interference	per EN 61000-6-3

### Commercial data

PU (SPU)	1 pcs
Packaging type	Box
Country of origin	DE
GTIN	4066966806373
Customs tariff number	85371091990

### Product Classification

ETIM 9.0	EC000236
ETIM 10.0	EC000236
ECCN	NO US CLASSIFICATION

### Environmental Product Compliance

RoHS Compliance Status	Compliant, No Exemption
------------------------	-------------------------

Approvals / Certificates

General approvals



Approval	Standard	Certificate Name
KC National Radio Research Agency	Article 58-2, Clause 3	R-R-W43-CC751
UL Underwriters Laboratories Inc. (ORDINARY LOCATIONS)	UL 61010-2-201	E175199

Declarations of conformity and manufacturer's declarations

Approval	Standard	Certificate Name
EU-Declaration of Conformity WAGO GmbH & Co. KG	-	-
UK-Declaration of Conformity WAGO GmbH & Co. KG	-	-

Downloads

Environmental Product Compliance

Compliance Search

Environmental Product Compliance 751-9412



1 Compatible Products

1.1 Optional Accessories

1.1.1 Female connector

1.1.1.1 Female connector/socket



**Item No.: 2091-1130**  
1-conductor female connector; push-button; Push-in CAGE CLAMP®; 1.5 mm²; Pin spacing 3.5 mm; 10-pole; 1,50 mm²; light gray



**Item No.: 2091-1110/002-000**  
1-conductor female connector; push-button; Push-in CAGE CLAMP®; 1.5 mm²; Pin spacing 3.5 mm; 10-pole; Gripping plate sliding connector release; 1,50 mm²; light gray



**Item No.: 2091-1110**  
1-conductor female connector; push-button; Push-in CAGE CLAMP®; 1.5 mm²; Pin spacing 3.5 mm; 10-pole; Gripping plate; 1,50 mm²; light gray



**Item No.: 2091-1122**  
1-conductor female connector; push-button; Push-in CAGE CLAMP®; 1.5 mm²; Pin spacing 3.5 mm; 2-pole; 1,50 mm²; light gray



**Item No.: 2091-1102/002-000**  
1-conductor female connector; push-button; Push-in CAGE CLAMP®; 1.5 mm²; Pin spacing 3.5 mm; 2-pole; Gripping plate sliding connector release; 1,50 mm²; light gray



**Item No.: 2091-1102**  
1-conductor female connector; push-button; Push-in CAGE CLAMP®; 1.5 mm²; Pin spacing 3.5 mm; 2-pole; Gripping plate; 1,50 mm²; light gray



**Item No.: 2091-1124**  
1-conductor female connector; push-button; Push-in CAGE CLAMP®; 1.5 mm²; Pin spacing 3.5 mm; 4-pole; 1,50 mm²; light gray



**Item No.: 2091-1104/002-000**  
1-conductor female connector; push-button; Push-in CAGE CLAMP®; 1.5 mm²; Pin spacing 3.5 mm; 4-pole; Gripping plate sliding connector release; 1,50 mm²; light gray



**Item No.: 2091-1104**  
1-conductor female connector; push-button; Push-in CAGE CLAMP®; 1.5 mm²; Pin spacing 3.5 mm; 4-pole; Gripping plate; 1,50 mm²; light gray

## 1.1.2 Memory card

### 1.1.2.1 Memory card



Item No.: [758-879/000-3102](#)

Memory Card SD Micro; 2 GByte

Item No.: [758-879/000-3108](#)

Memory Card SD Micro; pSLC-NAND; 8 GB; Temperature range: -40 to 90°C

## 1.1.3 Tool

### 1.1.3.1 Operating tool



Item No.: [2092-1630](#)

Unlocking tool; orange

# List of Tables

Table 1	Marking .....	14
Table 2	Etikett.....	15
Table 3	Structure of the UII.....	16
Table 4	Update Matrix.....	16
Table 5	ETHERNET Interface Pin Assignment.....	17
Table 6	Pin Assignment Supply Voltage .....	17
Table 7	Digital Input Pin Assignments .....	17
Table 8	Digital Input/Output Pin Assignments.....	18
Table 9	Analog Input Pin Assignments .....	19
Table 10	Analog Inputs/Outputs Pin Assignments.....	20
Table 11	Analog Temperature Sensor Pin Assignments.....	20
Table 12	Communication Interface X8 Pin Assignment .....	21
Table 13	Communication Interface X11 Pin Assignment.....	21
Table 14	System/Fieldbus LED Indicators.....	22
Table 15	LNK/ACT LED Indicators.....	22
Table 16	Memory Card Slot LED Indicator.....	23
Table 17	DI/DIO LED indicator.....	23
Table 18	Operating mode switch.....	23
Table 19	Mounting Positions and Permissible Ambient Temperatures.....	25
Table 20	Compatibility Overview .....	29
Table 21	“SYS” Diagnostic LED.....	36
Table 22	“RUN” Diagnostic LED.....	36
Table 23	“USR” Diagnostics LED .....	37
Table 24	LNK ACT Diagnostic LED .....	37
Table 25	Memory Card Slot Diagnostic LED.....	38
Table 26	Diagnostics LEDs DI<n> .....	38
Table 27	Diagnostics LEDs DIO<n> .....	38

# List of Figures

Figure 1	Ansicht .....	13
Figure 2	Marking (Example).....	14
Figure 3	Label (Example) .....	15
Figure 4	UII Structure (Example) .....	16
Figure 5	ETHERNET Interface Pin Assignment .....	17
Figure 6	RS-485 Bus Termination.....	22
Figure 7	Circuit Diagram .....	24
Figure 8	Distances .....	27
Figure 9	Inserting Controller .....	31
Figure 10	Removing the Female Connector without Wiring (Application Example) .....	32
Figure 11	Removing the Female Connector with Wiring (Application Example).....	32

**WAGO GmbH & Co. KG**

Postfach 2880 · D - 32385 Minden  
Hansastraße 27 · D - 32423 Minden

✉ [info@wago.com](mailto:info@wago.com)  
🌐 [www.wago.com](http://www.wago.com)

Headquarters	+49 571/887 – 0
Sales	+49 (0) 571/887 – 44 222
Order Service	+49 (0) 571/887 – 44 333

WAGO is a registered trademark of WAGO Verwaltungsgesellschaft mbH.  
Copyright – WAGO GmbH & Co. KG – All rights reserved. The content and structure of the WAGO websites, catalogs, videos and other WAGO media are subject to copyright. Distribution or modification of the contents of these pages and videos is prohibited. Furthermore, the content may neither be copied nor made available to third parties for commercial purposes. Also subject to copyright are the images and videos that were made available to WAGO GmbH & Co. KG by third parties.