

Configurable M12 connector, unshielded

1/1

Screw connection technology (Supply), Spring clamp technology (CANopen / DeviceMet)

Data Sheet

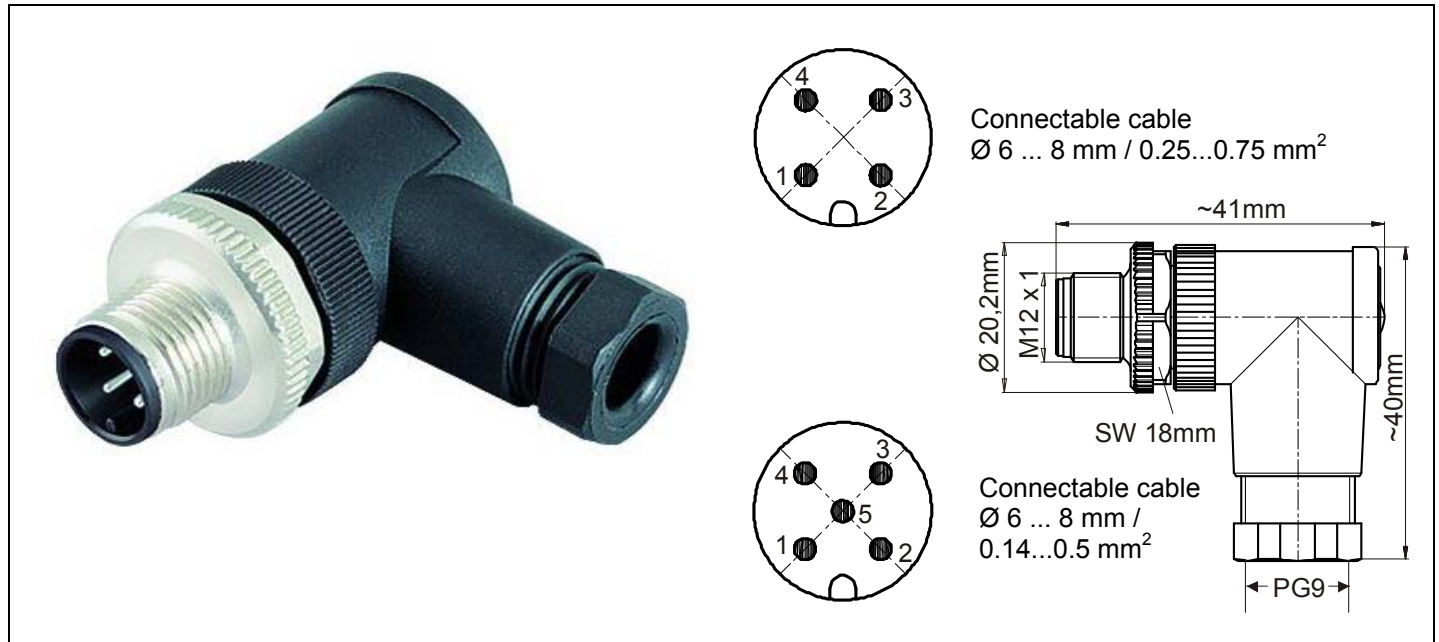

Description	Item no.	Pack. unit pcs
M12 plug, A-coded, right angle, screw technology, PG 9	756-9206/0040-0000	1
M12 plug, A-coded, right angle, 5-poles, spring clamp technology; PG 9	756-9206/0050-0000	1

Mounting

A = 7mm (spring clamp technology)
A = 5mm (screw clamp technology)

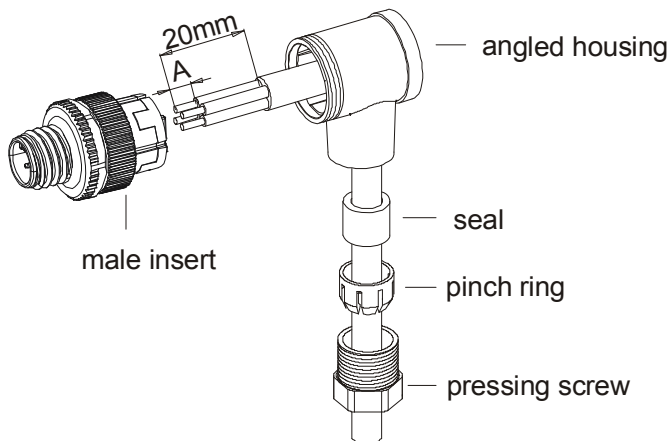

Only for spring clamp version

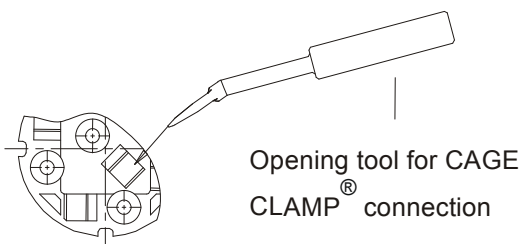

Technical data

General:

Housing material	Polybutylene terephthalate (PBT)
Housing surface	brass (CuZn)
Insert material	Polyamid (PA) / PBT
Contact plating	Gold (Au)
Type of connection	Screw respectively spring clamp
Seal	Neoprene
Temperature range	-25 °C...+85 °C
Cable entry	Ø 6-8 mm
Kind of locking	Screw locking M12
Mating cycles	>100
Class of protection	IP67 in locked position

Electrical data:

Pole number	4 / 5
Contact number	4 / 5
Conductor size	
Screw technology	0.25...0.75 mm ²
Spring clamp technology	0.14...0.5 mm ²
Rated current	4 A (40 °C)
Rated voltage	250 V / 60 V
Test voltage	AC 2.5 kV / AC 1.5 kV
Overvoltage category	II
Material group	III/II
Transition resistance	≤3 mΩ
Pollution degree	3