



WAGO TO-PASS[®] 761

Telecontrol Modules S

761-10x

Assembly, Installation and Handling

Copyright © 2007 by WAGO Kontakttechnik GmbH & Co. KG
All rights reserved.

WAGO Kontakttechnik GmbH & Co. KG

Hansastraße 27
D-32423 Minden

Phone: +49 (0) 571/8 87 – 0
Fax: +49 (0) 571/8 87 – 1 69

E-Mail: info@wago.com

Web: <http://www.wago.com>

Technical Support

Phone: +49 (0) 571/8 87 – 5 55
Fax: +49 (0) 571/8 87 – 85 55

E-Mail: support@wago.com

Every conceivable measure has been taken to ensure the accuracy and completeness of this documentation. However, as errors can never be fully excluded, we always appreciate any information or suggestions for improving the documentation.

E-Mail: documentation@wago.com

We wish to point out that the software and hardware terms as well as the trademarks of companies used and/or mentioned in the present manual are generally protected by trademark or patent.

Table of contents

Table of contents.....	3
1 Important Notes	5
1.1 Legal Principles	5
1.1.1 Copyright.....	5
1.1.2 Personnel Qualification.....	5
1.1.3 Proper Use of the <i>TO-PASS</i> [®] Telecontrol Modules.....	6
1.1.4 Technical Condition of the Devices.....	6
1.2 Standards and Regulations for Operating the <i>TO-PASS</i> [®] Telecontrol Modules.....	7
1.3 Symbols.....	8
1.4 Safety Information	9
1.5 Font Conventions	10
1.6 Number Notation	10
2 Use	11
3 Products	12
4 Scope of Delivery.....	12
5 View.....	13
6 Installing the Operator Software.....	14
7 Assembly	15
7.1 Installation.....	15
7.2 Terminal Assignment.....	16
7.2.1 Operating Voltage	16
7.2.2 Digital Inputs.....	16
7.2.3 Analog Inputs	17
7.2.4 Digital Outputs	17
7.2.5 Analog Outputs	18
7.2.6 Antenna	18
7.2.7 Serial interface to the PC.....	19
7.3 Examples of Connection.....	20
7.3.1 Digital Inputs.....	20
7.3.2 Analog Inputs	20
7.3.3 Digital Outputs	21
8 Display Elements.....	22
9 Commissioning	23
10 Parameter Setting	25
10.1 General Settings	25
10.2 Read Parameters.....	26
10.3 Identity	27
10.4 Addresses	28
10.5 Input and Output Configuration.....	30
10.5.1 Digital Inputs.....	30
10.5.2 Multiplex Input.....	31
10.5.3 Analog Inputs	33

10.5.4	Digital Outputs	35
10.6	Configure Fault Indicator	36
10.6.1	Alarm messages from Digital Inputs.....	36
10.6.2	Limit Value Messages of Analog Inputs.....	36
10.6.3	Acknowledgement.....	37
10.7	Transmission Refresh Times	38
10.8	Time Control	39
10.9	Write Parameters	40
11	Handling.....	41
11.1	Remote Query of Process Values.....	41
11.1.1	Query via SMS	41
11.1.2	Query with the <i>TO-PASS</i> [®] Operator Program	42
11.2	Telecontrol	43
11.2.1	Telecontrol via SMS	43
11.2.2	Telecontrol with the <i>TO-PASS</i> [®] Operator Program	44
11.3	Acknowledge Fault Messages.....	45
11.4	Switch Stand-by State	46
12	Diagnostics	47
12.1	Test Inputs and Outputs	47
12.2	Test the Connection.....	48
12.3	Test the Modem.....	48
13	<i>WAGO-TO-PASS</i>[®] Web.....	49
13.1	Set Parameters	49
13.2	Web Refresh.....	50
13.2.1	Data Format.....	50
13.2.2	Response	51
13.2.3	Example (Request).....	51
13.3	WebLog.....	52
13.3.1	Data format.....	52
13.3.2	Data Format of a Data Record	52
13.3.3	Use.....	53
14	Disclaimer	54
15	Technical Data.....	55
	List of Figures	56
	List of Tables.....	57

1 Important Notes

This section provides a summary of the most important safety requirements and notes which are also mentioned in the individual sections. To protect your health and prevent damage to the devices, it is essential to read and carefully follow the safety guidelines.

1.1 Legal Principles

1.1.1 Copyright

This manual including all figures and illustrations contained therein is subject to copyright. Any use of this manual which infringes the copyright provisions stipulated herein, is not permitted. Reproduction, translation and electronic and phototechnical archiving and amendments require the written consent of WAGO Kontakttechnik GmbH & Co. KG, Minden. Non-compliance shall attract claim for damages.

WAGO Kontakttechnik GmbH & Co. KG reserves the right to enact changes that serve technical progress.

All rights arising from the issue of a patent, or the legal protection of utility patents, are reserved to WAGO Kontakttechnik GmbH & Co. KG. Third-party products are always indicated without any notes concerning patent rights. Thus, the existence of such rights must not be excluded.

1.1.2 Personnel Qualification

The use of the product described in this manual requires special qualifications, as shown in the following table:

Table 1: Personnel Qualification

Activity	Electrical specialist
Assembly	X
Commissioning	X
Programming	X
Maintenance	X
Troubleshooting	X
Disassembly	X

All personnel must be familiar with the applicable standards.

WAGO Kontakttechnik GmbH & Co. KG declines any liability resulting from improper action and damage to WAGO products and third-party products due to non-observance of the information contained in this manual.

1.1.3 Proper Use of the *TO-PASS*[®] Telecontrol Modules

The *TO-PASS*[®] telecontrol modules receive digital and analog signals from sensors and transmit and output them to higher-ranking controllers. Additionally, it is possible to (pre-)process them.

The device is designed for the IP20 protection class. It is protected against the insertion of solid items (e.g. fingers) and solid impurities up to 12.5 mm in diameter, but not against water penetration. Unless otherwise specified, the device must not be operated in wet and dusty environments.

1.1.4 Technical Condition of the Devices

For each individual application, the components are supplied from the factory with a dedicated hardware and software configuration. Changes in hardware, software and firmware are only admitted within the framework of the possibilities documented in the manuals. All changes to the hardware and/or software and the non-conforming use of the components entail the exclusion of liability on the part of WAGO Kontakttechnik GmbH & Co. KG.

Please direct any requirements pertaining to a modified and/or new hardware or software configuration directly to WAGO Kontakttechnik GmbH & Co. KG.

1.2 Standards and Regulations for Operating the *TO-PASS*[®] Telecontrol Modules

Please observe the standards and regulations that are relevant to installation:

- The data and power lines must be connected and installed in compliance with the standards to avoid failures on your installation and eliminate any danger to personnel.
- For installation, startup, maintenance and repair, please observe the accident prevention regulations of your machine (e.g., BGV A 3, "Electrical Installations and Equipment").
- Emergency stop functions and equipment must not be deactivated or otherwise made ineffective. See relevant standards (e.g., DIN EN 418).
- Your installation must be equipped in accordance to the EMC guidelines so electromagnetic interferences can be eliminated.
- Please observe the safety measures against electrostatic discharge according to DIN EN 61340-5-1/-3. When handling the modules, ensure that environmental factors (persons, workplace and packing) are well grounded.
- The relevant valid and applicable standards and guidelines regarding the installation of switch cabinets must be observed.

1.3 Symbols

DANGER

Warning of physical injury

Indicates a direct hazard with a high level of risk, which may lead to death or severe physical injury if it is not avoided.

DANGER



Warning of physical injury due to electric current

Indicates a direct hazard with a high level of risk, which may lead to death or severe physical injury if it is not avoided.

WARNING

Warning of physical injury

Indicates possible hazard with a moderate level of risk, which may lead to death or (severe) physical injury if it is not avoided.

CAUTION

Warning of physical injury

Indicates possible hazards with a low level of risk, which will lead to minor or moderate physical injuries if it is not avoided.

NOTICE

Warning of damage to equipment

Indicates possible hazard that could lead to equipment damage if it is not avoided.

NOTICE



Warning of damage to equipment by electrostatic discharge

Indicates possible hazard that could lead to equipment damage if it is not avoided.

NOTE:



Please note

Indicates possible malfunction, which does not lead to equipment damage if it is not avoided.

Information



Notes on additional information

Indicates other informations, which are not an integral part of this documentation, such as Internet.

1.4 Safety Information

DANGER

Warning of physical injury

TO-PASS[®] telecontrol modules are exposed operating equipment. They may only be assembled in housings, cabinets or in electrical operation rooms. Access is only permitted via a key or tool to authorized qualified personnel.

DANGER

Warning of physical injury

All power sources to the device must always be switched off before performing any installation, repair or maintenance work..

NOTICE

Warning of damage to equipment

The components are not resistant against materials having seeping and insulating properties such as: aerosols, silicones, triglycerides (found in some hand creams). If it cannot be determined that these materials appear in the component environment, then the components must be installed in an enclosure that is resistant against the above mentioned materials. Clean tools and materials are generally required to operate the device/module.

NOTICE

Warning of damage to equipment

Soiled contacts must be cleaned using oil-free compressed air or with ethyl alcohol and leather cloths.

NOTICE

Warning of damage to equipment

Do not use contact sprays, which could possibly impair contact area functionality.

NOTICE

Warning of damage to equipment

Avoid reverse polarity of data and power lines as this may damage the devices.

NOTICE



Warning of damage to equipment by electrostatic discharge

The devices are equipped with electronic components that may be destroyed by electrostatic discharge when touched.

1.5 Font Conventions

Table 2: Font Conventions

Font type	Indicates
<i>italic</i>	Names of paths and files are displayed in italics, e.g.: C:\Programme\WAGO-IO-CHECK
Menu	Menu options are displayed in bold, e.g.: Save
>	A greater-than sign between two names means the selection of a menu option from a menu. e.g.: File > New
Input	Designation of input or optional fields are displayed in bold, e.g.: Start of measurement range
“Value”	Input or selective values are displayed in inverted commas, e.g.: Enter the value “4 mA” under Start of measurement range .
[Button]	Button names in dialog boxes are displayed in bold in square brackets, e.g.: [Input]
[Key]	Names of keys on the keyboard are displayed in bold in square brackets, e.g.: [F5]

1.6 Number Notation

Table 3: Number Notation

Number code	Example	Note
Decimal	100	Normal notation
Binary	'100' '0110.0100'	Within ', Nibble separated with dots

2 Use

The *TO-PASS*[®] product family is designed for wireless communication of signals and messages.

This includes:

- compact module for the connection of signals from plants
- transmission
- preparation of values for the operator.

The system is connected in wireless mode to PCs, hand computers, Internet PCs, web servers, mobile telephones, fax, e-mail receivers or land-line telephones. Influences to the system are also possible.

Communication occurs using the global mobile radio network “GSM” (Global System for Mobile Communication). A SIM card is required for the *TO-PASS*[®] telecontrol module to use this network. As in the case of a mobile telephone, the *TO-PASS*[®] telecontrol module requires the SIM card in order to be able to “log on” to the network.

No other components are required, other than the SIM card to connect to the GSM mobile radio network and a GSM antenna (available as an accessory). Modems and interfaces are already installed in the *TO-PASS*[®] telecontrol module.

TO-PASS[®] telecontrol modules may be used as:

- permanent on-line link
- fault indicator
- remote data request system
- data memory
- telecontrol modules.

In doing so, the modules of the *WAGO TO-PASS*[®] are classified as follows:

- *WAGO TO-PASS*[®] S - “S” = small, compact module
- *WAGO TO-PASS*[®] M - “M” = medium, universal compact module.

3 Products

Table 4: Products

Item number	Name
761-100	Telecontrol Module S, 4 digital inputs, 4 digital outputs
761-101	Telecontrol Module S 8AI, 4 digital inputs, 4 digital outputs, 2 analog inputs
761-102	Telecontrol module S 8AI ESP, 4 digital inputs, 4 digital outputs, Internet access via GPRS
761-103	Telecontrol module S 8AI DSP, 4 digital inputs, 4 digital outputs, 2 analog inputs Internet access via GPRS

4 Scope of Delivery

The scope of delivery of the *TO-PASS*[®] S telecontrol module, without options, includes only the *TO-PASS*[®] S telecontrol module. Suitable antennas are available as accessories.

NOTE: **SIM Card**



Please note that one SIM card is required to operate each *TO-PASS*[®] S telecontrol module and may be obtained from typical service providers such as T-Mobile, VODAFONE or EPlus. WAGO Kontakttechnik GmbH & Co. K.G. is prepared to assist with the selection of the most cost-effective tariff for your application.

5 View

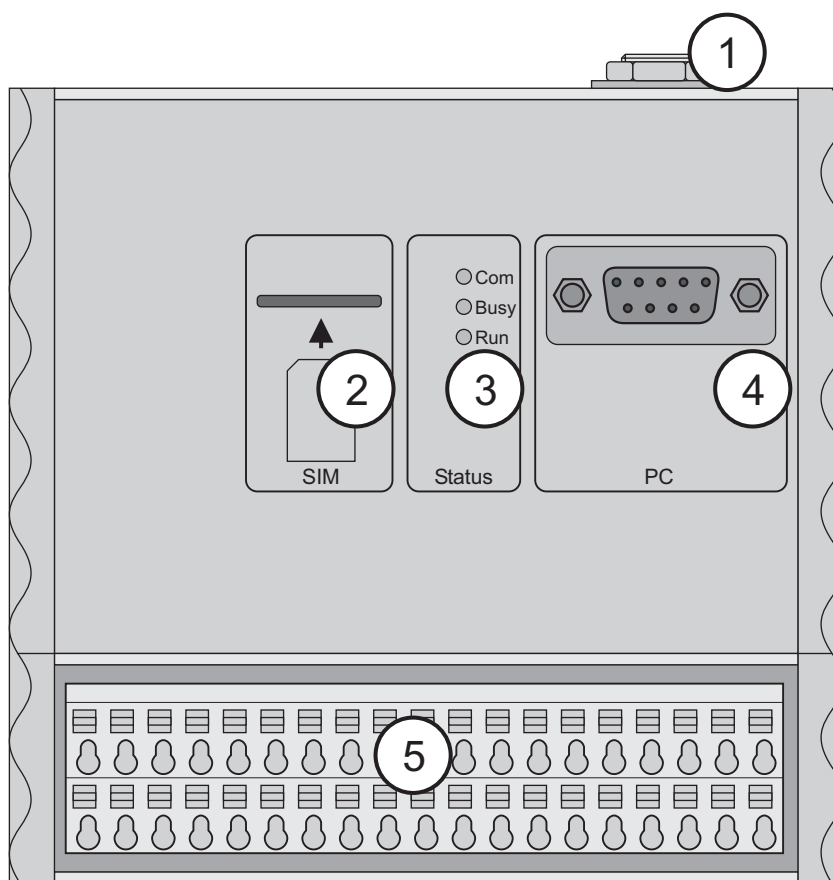

Figure 1: Front view

Position	Description
1	Antenna connection
2	SIM Card insert
3	Status indication
4	PC Interface
5	Connecting terminals for the supply, inputs and outputs

6 Installing the Operator Software

1. Insert the CD with the *TO-PASS*[®] operator software in the CD ROM drive of the PC
2. Close all applications allowing the Operating System to display the Desktop.
3. Move the mouse cursor to the “Start” button of the Windows Operating System and click on the right mouse button.
4. Select Windows “Explorer” using a double click.
5. Select the CD ROM drive where the operator software will be inserted.
6. Select the main directory of the CD and start the program “*WAGO-TO-PASS_SETUP(x.yy).EXE*”.
7. Follow the menu guide to choose a default installation path.
8. The installation is complete when the message “The software has been installed successfully” is displayed.

7 Assembly

7.1 Installation

1. The *TO-PASS*[®] S telecontrol module is designed to mount on a DIN 35 carrier rail.
2. The protection class of the *TO-PASS*[®] S telecontrol module is IP 20. This is why it is recommended that the module is mounted in a housing or a in a switching cabinet.
3. The *TO-PASS*[®] S telecontrol module is designed for an ambient operating temperature range of -20 °C to +70 °C. In the event of higher or lower temperatures, proper cooling or heating arrangements must be provided. Please contact WAGO Kontaktechnik GmbH & Co. K.G. for assistance.

7.2 Terminal Assignment

After installation, connect the wires depending on their use according to the following connecting diagrams:

7.2.1 Operating Voltage

Table 5: Terminal assignment for operating voltage

1	3	5	7	9	11	13	15	17	19	21	23	25	27	29	31	33	35	37
Uv	GND	DI1	DI3	DI5	DI7	AI1	AI2	AI3	AI4	AI5	AI6	AI7	AI8	AO1	AO2	DO1	DO3	DO
						+	+	+	+	+	+	+	+	+	+			Vcc
2	4	6	8	10	12	14	16	18	20	22	24	26	28	30	32	34	36	38
Uv	GND	DI2	DI4	DI6	DI8	AI1	AI2	AI3	AI4	AI5	AI6	AI7	AI8	AO1	AO2	DO2	DO4	Shield
						-	-	-	-	-	-	-	-	-	-	-	-	

Figure 2: Terminal assignment for operating voltage

Connection	Short name	Designation
1	Uv	Operating voltage (+) 8 to 36 VDC
2	Uv	Operating voltage (+) 8 to 36 VDC (parallel to terminal 1)
3	GND	Operating voltage (-) "Ground"
4	GND	Operating voltage (-) "Ground" (parallel to terminal 3)
38	Shield	Enclosure screening, connection of the PE

7.2.2 Digital Inputs

Table 6: Terminal assignment for digital inputs

1	3	5	7	9	11	13	15	17	19	21	23	25	27	29	31	33	35	37
Uv	GND	DI1	DI3	DI5	DI7	AI1	AI2	AI3	AI4	AI5	AI6	AI7	AI8	AO1	AO2	DO1	DO3	DO
						+	+	+	+	+	+	+	+	+	+			Vcc
2	4	6	8	10	12	14	16	18	20	22	24	26	28	30	32	34	36	38
Uv	GND	DI2	DI4	DI6	DI8	AI1	AI2	AI3	AI4	AI5	AI6	AI7	AI8	AO1	AO2	DO2	DO4	Shield
						-	-	-	-	-	-	-	-	-	-	-	-	

Figure 3: Terminal assignment for digital inputs

Connection	Short name	Designation
5	DI 1	Digital input 1
6	DI 2	Digital input 2
7	DI 3	Digital input 3
8	DI 4	Digital input 4
9	--	Not assigned
10	--	Not assigned
11	--	Not assigned
12	--	Not assigned

7.2.3 Analog Inputs

Table 7: Terminal assignment for analog inputs

1	3	5	7	9	11	13	15	17	19	21	23	25	27	29	31	33	35	37
Uv	GND	DI1	DI3	DI5	DI7	AI1	AI2	AI3	AI4	AI5	AI6	AI7	AI8	AO1	AO2	DO1	DO3	DO
						+	+	+	+	+	+	+	+	+	+			Vcc
2	4	6	8	10	12	14	16	18	20	22	24	26	28	30	32	34	36	38
Uv	GND	DI2	DI4	DI6	DI8	AI1	AI2	AI3	AI4	AI5	AI6	AI7	AI8	AO1	AO2	DO2	DO4	Shield
						-	-	-	-	-	-	-	-	-	-			

Figure 4: Terminal assignment for analog inputs

Connection	Short name	Designation
13	AI1+	Analog input 1 (+)
14	AI1-	Analog input 1 (-)
15	AI2+	Analog input 2 (+)
16	AI2-	Analog input 2 (-)
17	--	Not assigned
18	--	Not assigned
19	--	Not assigned
20	--	Not assigned
21	--	Not assigned
22	--	Not assigned
23	--	Not assigned
24	--	Not assigned
25	--	Not assigned
26	--	Not assigned
27	--	Not assigned
28	--	Not assigned

7.2.4 Digital Outputs

Table 8: Terminal assignment for digital outputs

1	3	5	7	9	11	13	15	17	19	21	23	25	27	29	31	33	35	37
Uv	GND	DI1	DI3	DI5	DI7	AI1	AI2	AI3	AI4	AI5	AI6	AI7	AI8	AO1	AO2	DO1	DO3	DO
						+	+	+	+	+	+	+	+	+	+			Vcc
2	4	6	8	10	12	14	16	18	20	22	24	26	28	30	32	34	36	38
Uv	GND	DI2	DI4	DI6	DI8	AI1	AI2	AI3	AI4	AI5	AI6	AI7	AI8	AO1	AO2	DO2	DO4	Shield
						-	-	-	-	-	-	-	-	-	-			

Figure 5: Terminal assignment for digital outputs

Connection	Short name	Designation
33	DO 1	Digital output 1
34	DO 2	Digital output 2
35	DO 3	Digital output 3
36	DO 4	Digital output 4
37	DO Vcc	(+) Voltage for the digital outputs

7.2.5 Analog Outputs

Table 9: Terminal assignment for analog outputs

1	3	5	7	9	11	13	15	17	19	21	23	25	27	29	31	33	35	37
Uv	GND	DI1	DI3	DI5	DI7	AI1	AI2	AI3	AI4	AI5	AI6	AI7	AI8	AO1	AO2	DO1	DO3	DO
						+	+	+	+	+	+	+	+	+	+			Vcc
2	4	6	8	10	12	14	16	18	20	22	24	26	28	30	32	34	36	38
Uv	GND	DI2	DI4	DI6	DI8	AI1	AI2	AI3	AI4	AI5	AI6	AI7	AI8	AO1	AO2	DO2	DO4	Shield
						-	-	-	-	-	-	-	-	-	-			

Figure 6: Terminal assignment for analog outputs

Connection	Short name	Designation
29	--	Not assigned
30	--	Not assigned
31	--	Not assigned
32	--	Not assigned

7.2.6 Antenna

The screw connector (FME plug) for the GSM antenna is located at the top of the housing.

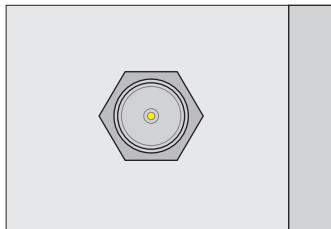

Figure 7: Antenna connection

7.2.7 Serial interface to the PC

Table 10: PC Interface

	Pin	Description
	1	Not assigned
	2	RXD
	3	TXD
	4	Not assigned
	5	GND
	6	Not assigned
	7	Not assigned
	8	Not assigned
9	Not assigned	

Figure 8:
PC Interface

Table 11: Interface cable allocation

WAGO TO-PASS			PC	
Pin	Description		Pin	Description
2	RXD	↔	2	RXD
3	TXD	↔	3	TXD
5	GND	↔	5	GND

NOTE:

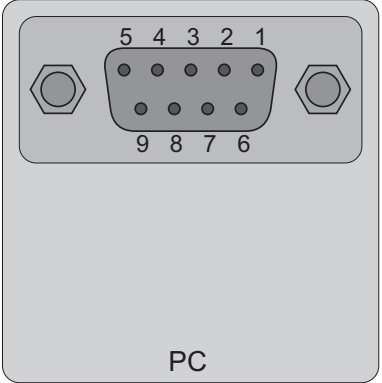

Connecting laptops and PCs without serial interface:

If the laptop or PC does not have a serial interface, use the USB adapter 761-9005, which is available as an accessory.

7.3 Examples of Connection

7.3.1 Digital Inputs

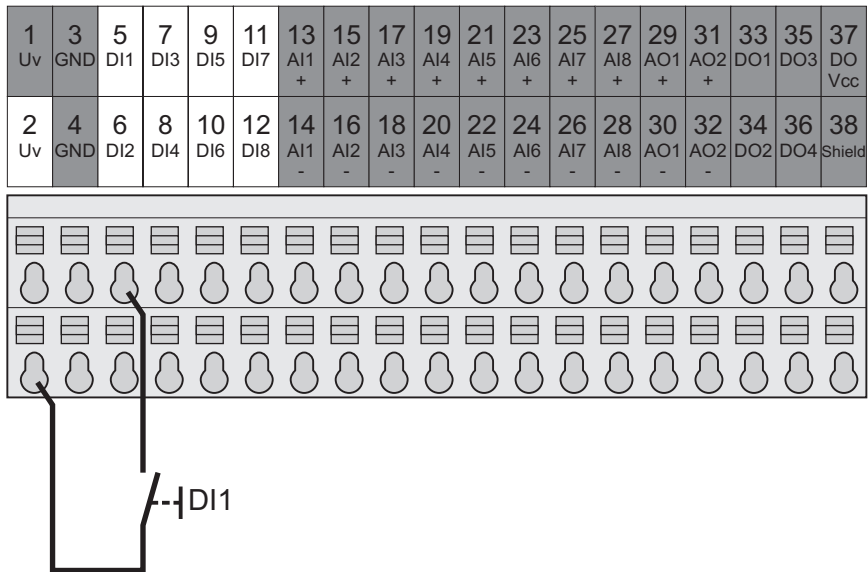

Figure 9: Example of connection for switch at input DI1

7.3.2 Analog Inputs

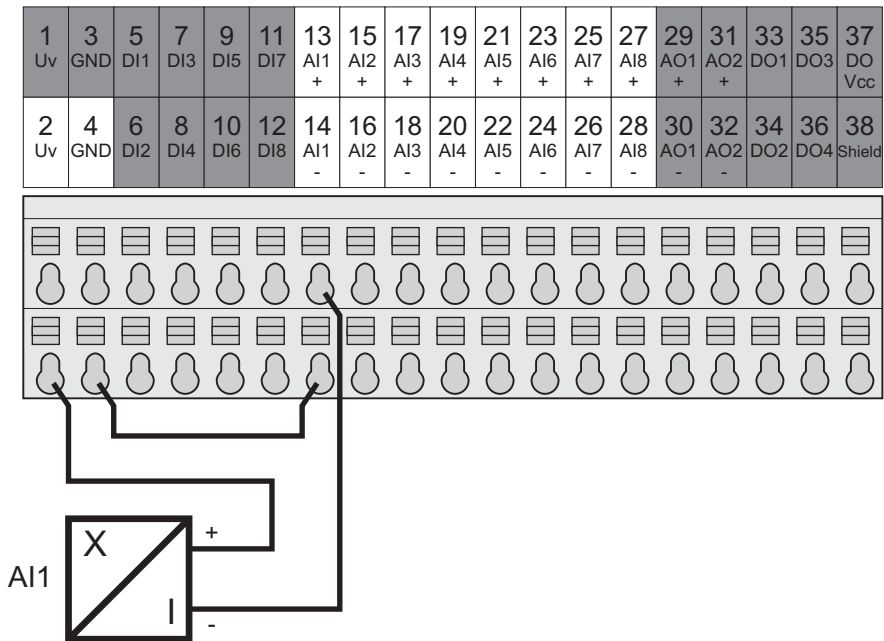

Figure 10: Example of connection of transducer at input AI1

7.3.3 Digital Outputs

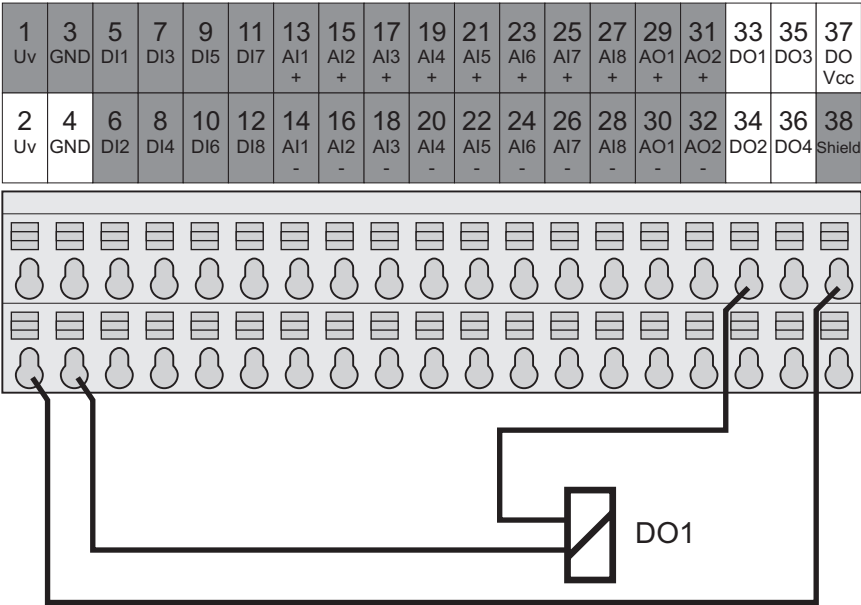

Figure 11: Example of connection of relay at output DO1

8 Display Elements

Table 12: Display Elements





	Com	Busy	Run	Description
	green	green	green	
	On	On	On	Initialization phase, after start-up, approx. 50 s, check and log on to the GSM network
	On	Off	On	Communication via RS232 interface
	Off	On	On	Communication via GSM modem
	Off	Off	2 Hz blinking	Error
	Off	Off	0.5 Hz blinking	Ready

Figure 12: Display Elements

9 Commissioning

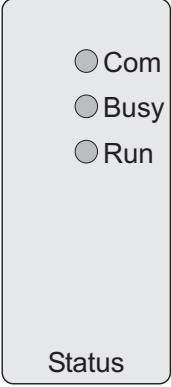
NOTE: **Do not switch on yet!**
 Switch on the *TO-PASS*[®] S telecontrol module only after being prompted to do so; do not insert the SIM card for this procedure.

NOTE: **Deactivate the PIN!**
 During the commissioning, the SIM card may be disabled when a faulty or incomplete PIN number is entered. Therefore it is recommended that you disable the PIN of the SIM card to be inserted. For this purpose, insert the SIM card in a mobile telephone and select the menu option **Security > Disable PIN**.

NOTE: **Deactivate the call diversion**
 Deactivate all call diversions of the SIM card to be inserted to achieve a trouble-free availability of the *TO-PASS*[®] S telecontrol module.

As the first step, the *TO-PASS*[®] S telecontrol module must be configured with a telephone number.

1. Each *TO-PASS*[®] S telecontrol module requires a SIM card for operation, which may be obtained from any mobile telephone service provider. Special data cards are recommended.
2. Each SIM card contains a telephone number and a PIN code, which the SIM card enables for operation in the *TO-PASS*[®] S telecontrol module. Keep this telephone number and PIN code at hand.
3. Connect the PC to the mounted *TO-PASS*[®] S telecontrol module via serial interface.
4. If the PC has only USB interfaces, a USB – RS-232 adapter is required. A USB adapter is available as an accessory 761-9005.
5. Start the PC and then the *TO-PASS*[®] operator software.
6. Select the menu option **File > Set**.
7. Set this as a “RS232” connection and select the respective interface, e.g. “COM1”.
8. Select the menu option **File > New Module**.
9. In the input window enter the identity (max. 8 characters) of the new device. The identity is the name of the *TO-PASS*[®] S telecontrol module and serves as an identifier. It can be changed subsequently only after overwriting it. The identifier is also transmitted in the event of error messages as SMS, fax, or e-mail and should be an identifier for the location of use, such as “Tank1”.

10. A new module will be created at the top left of the screen in the project tree. Click on “+” so the tree expands. Go to “Identity” and enter the telephone number of the SIM card in the second line at the top right of the screen. Deactivate the pushbutton **[Use PIN]** in the following line so that the *TO-PASS*[®] S telecontrol module does not use the PIN Code. Also deactivate the PIN Code on the SIM Card! For this purpose, insert the SIM card in a mobile telephone and select the option **Disable PIN** in the **Security** menu.
11. If the PIN Code has to be used, activate the **[Use PIN]** button in the *TO-PASS*[®] operating software. Also activate the PIN Code of your SIM-Card using your mobile telephone.
12. The telephone number should be the data number of the SIM card if it is available. If using a tariff that does not offer any data transmission options (which means that no data number is available) then, apart from SMS, e-mail and fax operation, it is possible to select the *TO-PASS*[®] S telecontrol module via remote configuration only with the help of a GSM modem.
13. Switch on the power to the *TO-PASS*[®] S telecontrol module. Shortly afterward, the “Busy” LED will flash.
14. Select the menu option **Edit > Write Parameters** in the operator software. The operator software now transmits the parameters in the *TO-PASS*[®] S telecontrol module.
15. After error-free transmission, switch off the *TO-PASS*[®] S telecontrol module.
16. Carefully push the SIM Card into the SIM Card slot of your *TO-PASS*[®] S telecontrol module (e.g. using a screw driver) until it locks into position. The SIM Card is then positioned 2 mm within the enclosure. The SIM Card is released by pressing it again.
17. Switch on the *TO-PASS*[®] S telecontrol module again and wait until the initialization phase is complete. The initialization phase ends when the “Run” LED lights up with brief flashes.
18. The *TO-PASS*[®] S telecontrol module is now ready for use and configuration. For this purpose, follow the instructions given in the “Configuration” section.

10 Parameter Setting

10.1 General Settings

Select the menu point **File > Settings**, for carrying out general settings, such as type of connection, interface or language for the *TO-PASS*[®] operating interface.



Figure 13: General settings

Connection	
RS232 / GSM / Analog / ISDN	Select the type of connection for communicating with the <i>TO-PASS</i> [®] S telecontrol module: RS232 Direct connection via the RS232-Cable, GSM Access via GSM-modem at the PC, Analog Access via analog modem at the PC, ISDN Access via ISDN-modem at the PC.
Comport	
COM1 ... COMx	Here, select the serial interface where the communication cable is connected with a RS232 connection.
Language	
English / German / French	Select the language for the <i>TO-PASS</i> [®] operator interface here.

Using the button [**Save**], the settings are taken over and the dialog window is closed.

Using the button [**Cancel**], the dialog window is closed without taking over the settings.

10.2 Read Parameters

After you have set the type of connection for communicating with the *TO-PASS*[®] S telecontrol module, you are then able to read-out the parameters of the connected module.

For this purpose, select the menu point **Controller > Read Parameters**. The software now reads out all the parameters of the *TO-PASS*[®] S telecontrol module.

Then you can adapt the parameter according to your requirements.

10.3 Identity

Select the *TO-PASS*[®] S telecontrol module to be configured from the project tree; under it, select the **Identity** option.

On the right side you will find the display field for the name, the input field for the telephone number, buttons and input fields for the PIN and roaming and the input field for the alarm counter.

The screenshot shows a configuration window titled 'General:'. It contains the following elements:

- Name:** A text input field containing 'Modul1'.
- Phone:** A text input field containing '0123456789'.
- Pin:** A button labeled 'Use pin' next to a masked text input field containing '*****'.
- Roaming:** A button labeled 'Allow' next to an empty text input field.
- Alarm counter:** A text input field containing '0', with a note '[0 = off; 1..99 alarms]' to its right.

Figure 14: Configuring the identity

General	
Name	The module name is assigned when a new module is set up and cannot be subsequently changed.
Phone	Enter the telephone number of the SIM card inserted into the module.
Pin	If you wish to use the PIN number of the SIM card inserted, press the [Use pin] button and enter the PIN number.
Roaming	If you want to enable roaming, press the [Enable] button.
Alarm counter	If you want to limit the number of alarms transmitted each minute (e.g., in case of a damaged cable), then enter the maximum number of desired alarms here.

10.4 Addresses

The *TO-PASS*[®] S telecontrol module can communicate with a maximum of four transmitters/receivers via GSM.

Messages are sent by the *TO-PASS*[®] S telecontrol module as SMS: however, they can also be sent as an e-mail, fax or voice mail through configuration.

In addition, the *TO-PASS*[®] S telecontrol module can transmit messages to an Internet address.

Select the *TO-PASS*[®] S telecontrol module to be configured from the project tree and the option **Addresses**.

The input fields for the addresses are on the right side:

The screenshot shows a configuration window with two main sections. The first section is titled "Phone/Fax/Mail:" and contains four rows, each with a label "Adress 1:" through "Adress 4:", a text input field, and a button labeled "T2T". The second section is titled "Internet:" and contains seven rows, each with a label and a text input field: "Host adress:", "Host port:" (with the value "80" entered), "Script (Values):", "Script (Logger):", "Access server:", "User:", and "Password:".

Figure 15: Configuring the addresses

Phone/Fax/Mail	
Address 1 ... Address 4	<p>Transmission as SMS: Simply enter the mobile telephone number of the receiver. Press the pushbutton [T2T], when the SMS receiver is also a <i>TO-PASS</i>[®] telecontrol module, e.g. when alarm messages should be used as switching commands in the other <i>TO-PASS</i>[®] telecontrol module.</p> <p>Transmission as e-mail: First enter the e-mail identifier of the provider of the SIM card inserted in the WAGO-TO-PASS[®] telecontrol module. The following codes are applicable:</p> <ul style="list-style-type: none"> - T-Mobile: 8000 - VODAFONE: 3400 - E-Plus 7676245. <p>Then a comma (,) follows the end of a code, followed by the e-mail address, e.g. "8000,receiver@provider.net" if using a T-Mobile SIM card.</p> <p>Transmission as fax: Enter the code "99" directly preceding the fax number, e.g.: "99057123456789".</p>
Internet	
Host address	Enter the host address of the corresponding Web server, e.g. " www.to-pass.com " for testing.
Host port	80
Script (values)	Enter the script name of the corresponding database, e.g. "wago/savedataM15.php" for testing.
Script (logger)	No entry here, if script name has been entered at Script (values)!
Access server	Enter the name of the access server of the provider of the SIM card, e.g.: <ul style="list-style-type: none"> - T-Mobile: internet.t-mobile - Vodafone: web.vodafone.de
User	Regardless
Password	Enter the password for the access server, e.g.: <ul style="list-style-type: none"> - T-Mobile: T-D1 - Vodafone: d2

10.5 Input and Output Configuration

10.5.1 Digital Inputs

Select the *TO-PASS*[®] S telecontrol module from the project tree on the left using the identity. Select the input to be configured under the entry **Digital input**.

The parameters of the input are given on the right side.

The input fields are identical for all digital inputs:

The screenshot shows a configuration window for digital inputs. It is divided into two main sections: 'Alarm settings' and 'Reset settings'.
 In the 'Alarm settings' section:
 - 'Set text' is a text box containing 'DIN1 on'.
 - 'Address' is a row of buttons labeled 1, 2, 3, 4, and a larger button labeled 'Internet'.
 - 'Analog value' is a row of buttons labeled 1, 2, 3, 4, 5, 6, 7, and 8.
 In the 'Reset settings' section:
 - 'Reset text' is a text box containing 'DIN1 off'.
 - 'Address' is a row of buttons labeled 1, 2, 3, 4, and a larger button labeled 'Internet'.
 - 'Analog Value' is a row of buttons labeled 1, 2, 3, 4, 5, 6, 7, and 8.

Figure 16: Configuring the digital inputs

Alarm settings	
Set Text	Message text of the transmitted message when the digital input is set.
Address	Selection of where the message should be transmitted if the digital input is set. One or all addresses can be selected independently. Press the [Internet] button for applications having cyclic GPRS transmission.
Analog value	Up to four analog values can be clicked here, which should be transmitted in addition to the fault message.
Reset Text	Message text of the transmitted message when the digital input is reset.
Address	Selection of where the message should be transmitted if the digital input is reset. One or all addresses can be selected independently. Press the [Internet] button for applications having cyclic GPRS transmission.
Analog value	Up to four analog values can be clicked here, which should be transmitted in addition to the fault message.

10.5.2 Multiplex Input

The digital inputs DI1 ... DI4 can be configured as multiplex inputs. In such a case, these four inputs are read in as a combination and interpreted as a binary number. The following applies in this case:

$$\begin{aligned} \text{DI1} &= 2^0 = 1 \\ \text{DI2} &= 2^1 = 2 \\ \text{DI3} &= 2^2 = 4 \\ \text{DI4} &= 2^3 = 8 \end{aligned}$$

Thus, for example, if DI1 and DI3 are set, then the binary number is 5. If only DI4 is set, then the binary number is 8.

An alarm text can be defined for each of the 16 states (0 ... 15). The recipients of the alarm text message are selected with the help of the multiplex settings.

10.5.2.1 Multiplex Settings

Select the *TO-PASS*[®] S telecontrol module from the project tree on the left using the identity. Select the **Multiplex Settings** option under the **Multiplex Input** entry. The buttons for enabling multiplex operation and the selection of the recipients of the analog values to be transmitted are provided on the right side.

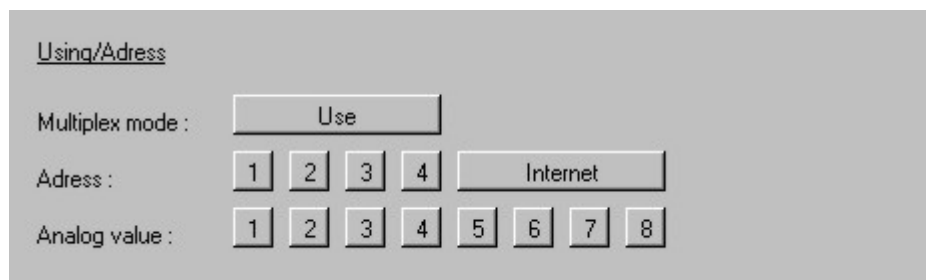

Figure 17: Configuring the multiplex settings

Using/Address	
Multiplex Mode	Press the button [Use] to enable or disable multiplex operation for the inputs DI1 ... DI4.
Address	Selection of where the message should be transmitted if the multiplex input has been set. One or more, or all addresses can be selected independently. Press the [Internet] button for applications having cyclic GPRS transmission.
Analog Values	Up to four analog values can be clicked here, which should be transmitted in addition to the multiplex message.

10.5.2.2 Multiplex Alarm Texts

Select the *TO-PASS*[®] S telecontrol module from the project tree on the left using the identity. Select the **Multiplex Table** option under the **Multiplex Input** entry. The input fields for the alarm texts pertaining to the 16 states are provided on the right side.

The screenshot shows a configuration window titled "Alarm text". On the left side, there is a vertical list of labels from "Value 0:" to "Value 15:". To the right of each label is a horizontal rectangular text input field. All input fields are currently empty.

Figure 18: Configuring the multiplex alarm texts

Alarm Text	
Value 0	Enter the various alarm texts to be transmitted for each of the states pertaining to the digital inputs.
...	
Value 15	

10.5.3 Analog Inputs

Select the *TO-PASS*[®] S telecontrol module from the project tree on the left using the identity. Select the input to be configured under the entry **Analog input**.

The parameters of the input are given on the right side.

The input fields are identical for all analog inputs:

The screenshot shows a software interface for configuring analog inputs. It is divided into two main sections: 'Norm settings' and 'Alarm settings'.

Norm settings:

- Input range:** Two buttons are visible: '0..20 mA' (selected) and '4..20 mA'.
- Min. value:** A text input field contains '0', with a range indicator '[-9999 .. 9999]' to its right.
- Max. value:** A text input field contains '100', with a range indicator '[-9999 .. 9999]' to its right.
- Unity:** A text input field contains '%', with a maximum length of 5 characters.

Alarm settings:

- First value:** A text input field contains '75', with two buttons: 'rise' (selected) and 'fall'.
- First text:** A text input field contains 'AIN1 max', with a maximum length of 5 characters.
- Adress:** A row of buttons labeled '1', '2', '3', '4', and 'Internet'.
- Analog value:** A row of buttons labeled '1', '2', '3', '4', '5', '6', '7', and '8'.
- Second value:** A text input field contains '25', with two buttons: 'rise' (selected) and 'fall'.
- Second text:** A text input field contains 'AIN1 min', with a maximum length of 5 characters.
- Adress:** A row of buttons labeled '1', '2', '3', '4', and 'Internet'.
- Analog value:** A row of buttons labeled '1', '2', '3', '4', '5', '6', '7', and '8'.

Figure 19: Configuring the analog inputs

Norm settings	
Input range	Select the input signal for the sensor connected to the <i>TO-PASS</i> [®] S telecontrol module.
Min. value	Starting value, from which the given value is normalized. This value corresponds to the minimum input current value of 4 mA or 0 mA.
Max. value	End value, up to which the given value is normalized. This value corresponds to the maximum input current 20 mA.
Unit	Enter the unit here with a maximum of 5 characters with which the normalized process value should be transmitted.

Alarm settings	
First value	First limit value, from which an alarm indication is triggered. Select whether the alarm indication should be triggered with overshoot or undershoot of the limit value.
First text	Alarm message that is triggered with overshoot or undershoot of the limit value.
Address	Selection of where the message should be transmitted. One or all addresses can be selected independently. Press the [Internet] button for applications having cyclic GPRS transmission.
Analog value	Up to four analog values can be clicked here, which should be transmitted in addition to the alarm message.
Second value	Second limit value, from which an alarm indication is triggered. Select whether the alarm indication should be triggered with overshoot or undershoot of the limit value.
Second text	Alarm message that is triggered with overshoot or undershoot of the limit value.
Address	Selection of where the message should be transmitted. One or all addresses can be selected independently. Press the [Internet] button for applications having cyclic GPRS transmission.
Analog value	Up to four analog values can be clicked here, which should be transmitted in addition to the alarm message.

10.5.4 Digital Outputs

Select the *TO-PASS*[®] S telecontrol module from the project tree on the left using the identity. Select the output to be configured under the entry **Digital output**.

The parameters of the output are given on the right side.

The input fields are identical for all digital outputs:

Remote settings :

Set text :

Reset text :

Reset time : [0 = off; 1..99 seconds]

Figure 20: Configuring the digital outputs

Settings	
Set text	If the <i>TO-PASS</i> [®] S telecontrol module receives this text as an SMS, it switches this digital output on and connects the DC voltage available at terminal 37 to the corresponding digital output.
Reset text	If the <i>TO-PASS</i> [®] S telecontrol module receives this text as an SMS, it switches this digital output off and disconnects the DC voltage available at terminal 37.
Reset time	If the digital output is switched on, it will remain on for this time period and thus connected to terminal 37. After the reset time expires, the digital output switches off voltage from terminal 37. The "0" value disables this function; i.e., the output remains active indefinitely after being switched on.

10.6 Configure Fault Indicator

The *TO-PASS*[®] S telecontrol module can transmit fault messages to maximum four receivers. The receivers are informed either directly one after another or (if configured) after expiration of the time delay for acknowledgment. The message is sent by the *TO-PASS*[®] S telecontrol module as an SMS; however, it can also be sent as an e-mail, fax or voice mail via configuration.

10.6.1 Alarm messages from Digital Inputs

If on or off states of digital inputs are to be sent as fault messages, then select the desired receiver for the respective states of the inputs with the help of the buttons [1] ... [4]. In addition, it is possible to specify the analog values that are transmitted along with the fault message.

10.6.2 Limit Value Messages of Analog Inputs

It is possible to specify a maximum of 2 limit values for every analog input for which limit value violations (overshoot or undershoot) should be sent as fault messages.

Enter the desired value and select whether the fault message should be sent for overshoot or undershoot of the limit value using the buttons **[rise]** or **[fall]**.

Select the desired receiver for the respective limit value using the buttons [1] ... [4]. In addition, it is possible to specify the analog values that are transmitted along with the fault message.

10.6.3 Acknowledgement

Acknowledgment is the confirmation that a message has actually been sent to the receiver. Select the *TO-PASS*[®] S telecontrol module from the project tree using the identifier. Select the entry **Quit function** under the option **Special functions**. The right side contains the input fields for the waiting time and the number of repetitions.

Settings :

Wait time : [0..99 minutes]

Repeat cycles : [0..99 times]

Figure 21: Configuring the acknowledgment response

Settings	
Wait time	<p>The <i>TO-PASS</i>[®] S telecontrol module waits briefly to be entered here and acknowledgment after it has transmitted an alarm message. The acknowledgment takes place with the help of a simple call by the receiver to the <i>TO-PASS</i>[®] S telecontrol module.</p> <p>The <i>TO-PASS</i>[®] S telecontrol module accepts the call and disconnects it automatically. An acknowledgment SMS with the identifier and the text “QUIT” is sent.</p>
Repeat cycles	<p>Set the cycle time here for checking for the acknowledgment. If no receiver acknowledges the message of the <i>TO-PASS</i>[®] S telecontrol module, then the entire cycle can be executed again, allowing the <i>TO-PASS</i>[®] S telecontrol module to inform the first address once again and wait for an acknowledgment.</p>

10.7 Transmission Refresh Times

Select the *TO-PASS*[®] S telecontrol module from the project tree using the identifier. Select the entry **Refresh times** under the option **Special functions**. The input fields for the web interval and the SMS interval are located on the right side.

Settings :

Web cycle time : [0..9999 minutes / to web server]

SMS cycle time : [0..9999 minutes / to first address]

Figure 22: Configuring the transmission repeat times

Settings	
WEB cycle time	<p>Enter the cycle time here in minutes, which are intervals that the <i>TO-PASS</i>[®] S telecontrol module should transmit to the Internet.</p> <p>If “0” is entered, the transmission is disabled.</p> <p>It is possible to enter a maximum value of 9999 minutes, which corresponds to approximately one transmission per week. The cycle time set determines the transmission costs.</p> <p>One transmission corresponds to approx. 1 kB.</p> <p>If setting a cycle time of 60 minutes (one transmission per hour) then the data volume generated per month is 1 kB * 24 hours * 30 days = 720 kB per month.</p> <p>A SIM card with an inclusive volume of 1 MB per month would suffice for this cycle time.</p>
SMS cycle time	<p>Enter the cycle time here in minutes at which the <i>TO-PASS</i>[®] S telecontrol module should transmit to the first receiver address configured.</p> <p>The SMS contains the status of the digital inputs, the values and units of the analog inputs, the status of the digital outputs and the values and units of the analog outputs.</p> <p>The cyclic SMS can, for example, be used for operational supervision.</p>

10.8 Time Control

Select the *TO-PASS*[®] S telecontrol module from the project tree using the identifier. Select the entry **Time control** under the option **Special functions**. The buttons for various settings pertaining to time adjustment are located on the right side.



Figure 23: Setting the time adjustment

Settings	
Time set	<p>If the [SMS] button is pressed, then the <i>TO-PASS</i>[®] S telecontrol module sends an SMS to itself and receives the current time from the time transmitted by this SMS. The time adjustment using an SMS takes place only once when the <i>TO-PASS</i>[®] S telecontrol module is restarted. This type of time adjustment using SMS transmission has an inaccuracy of approximately 10 seconds.</p> <p>If the [Internet] button is pressed, then the <i>TO-PASS</i>[®] S telecontrol module receives the time from the Internet server with every cyclic transmission to the Internet. This type of time adjustment using transmission to the Internet server has an inaccuracy of approximately 3 seconds.</p>

10.9 Write Parameters

After you have adapted all parameters to your requirements, you have to write these parameters to the module connected.

For this purpose, select the menu point **Controller > Write Parameters**. The software now writes all the parameters into the *TO-PASS*[®] S telecontrol module.

Then the *TO-PASS*[®] S telecontrol module is ready for operation.

11 Handling

11.1 Remote Query of Process Values

The *TO-PASS*[®] S telecontrol module offers two options for remote query of the process values available.

- query via SMS
- query with the *TO-PASS*[®] operator program.

11.1.1 Query via SMS

For query via SMS, please send an SMS with the text “State” to the *TO-PASS*[®] S telecontrol module. The *TO-PASS*[®] S telecontrol module responds promptly with an SMS containing all digital and analog process values to a mobile telephone.

Table 13: SMS installation

Value transmitted	Description
Module 1	Identity
10010011	Condition of the digital inputs 1 ... 8 (0 = not set, 1 = set)
+00000 mA	Analog input 1
+00000 mA	Analog input 2
+00000 mA	Analog input 3
+00000 mA	Analog input 4
+00000 mA	Analog input 5
+00000 mA	Analog input 6
+00000 mA	Analog input 7
+00000 mA	Analog input 8
0110	Condition of the digital outputs 1 ... 4 (0 = not set, 1 = set)
+00000 mA	Analog output 1
+00000 mA	Analog output 2
AC=99	Alarm counter (displays the alarms that are still possible per hour)
From:+0123456789	Telephone number of the <i>TO-PASS</i> [®] S telecontrol module
hh:mm dd-mm-yy	Time and date of the SMS

11.1.2 Query with the *TO-PASS*[®] Operator Program

For a process values query with the *TO-PASS*[®] operator program, please select the menu option **Visual > I/O values**. The program establishes a link to the *TO-PASS*[®] S telecontrol module selected. Please note the mode of accessing the *TO-PASS*[®] S telecontrol module, either via direct RS-232 cable connection or an analog ISDN or GSM modem dial-up. The selection is specified in the menu option **File > Set**.

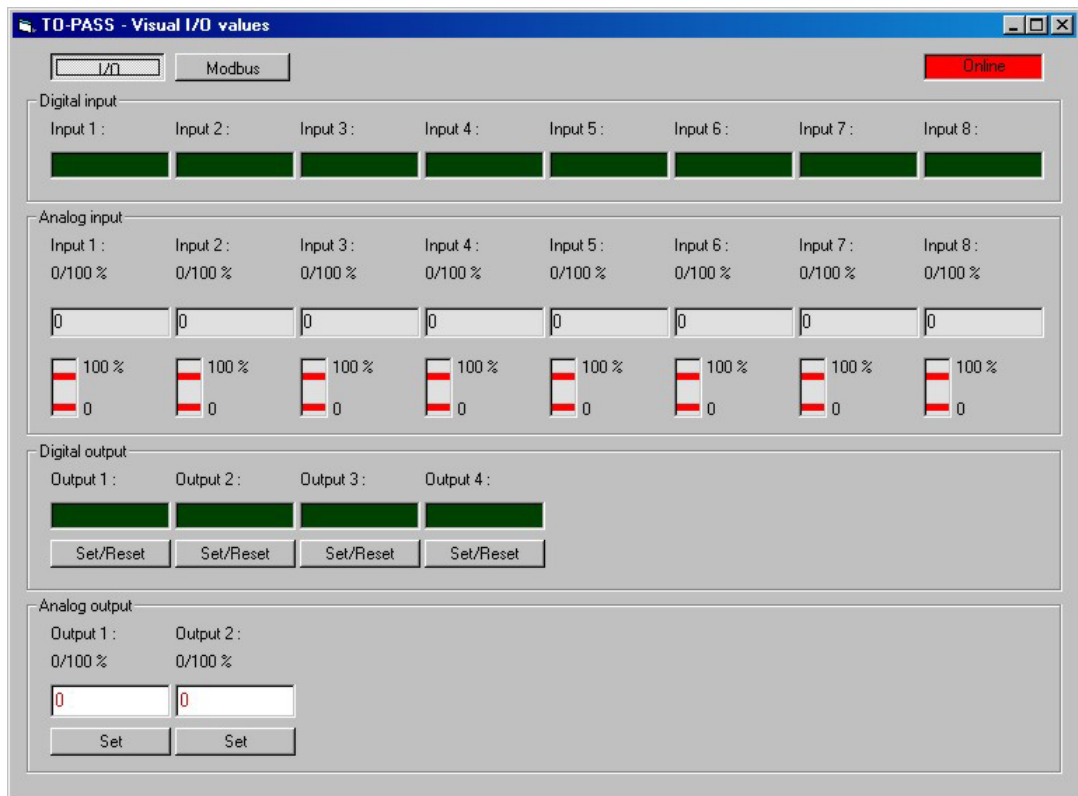

Figure 24: Visualization of the process values

Press the **[I/O]** button to display the process values of the digital and analog inputs and outputs. The process values displayed are valid if the on-line display is green.

Process values pertaining to digital and analog inputs are displayed in the upper portion of the window and those pertaining to digital outputs are displayed in the lower portion of the window.

11.2 Telecontrol

TO-PASS[®] S telecontrol modules offer the option of influencing a process remotely with the help of their analog and digital outputs. There are two methods available:

- telecontrol via SMS
- telecontrol with the *TO-PASS*[®] operator program.

11.2.1 Telecontrol via SMS

To set or reset a digital output, please send an SMS with the text that is entered under **Set text** and/or **Reset text** for this output to the *TO-PASS*[®] S telecontrol module.

The *TO-PASS*[®] S telecontrol module acknowledges the command with an SMS containing the identifier, the text sent and the current reading of the alarm counter.

Example:

Table 14: Example of parameter for Set DO

Parameter	Setting
Set	DOUT1=1
Reset	DOUT1=0
Reset time	0

Send an SMS with the text “DOUT1=1” to the *TO-PASS*[®] S telecontrol module in order to switch on the output 1.

The *TO-PASS*[®] S telecontrol module acknowledges the command with an SMS with the identifier, the text “DOUT1=1 OK!”.

Send an SMS with the text “DOUT1=0” to the *TO-PASS*[®] S telecontrol module in order to switch off the output 1.

The *TO-PASS*[®] S telecontrol module acknowledges the command with an SMS containing the identifier, the text “DOUT1=0 OK!”.

11.2.2 Telecontrol with the *TO-PASS*[®] Operator Program

For a process values query with the *TO-PASS*[®] operator program, please select the menu option **Visual > I/O values**. The program establishes a link to the *TO-PASS*[®] S telecontrol module selected. Please note the mode of accessing the *TO-PASS*[®] S telecontrol module, either via direct RS-232 cable connection or an analog ISDN or GSM modem dial-up. The selection is specified in the menu option **File > Set**.

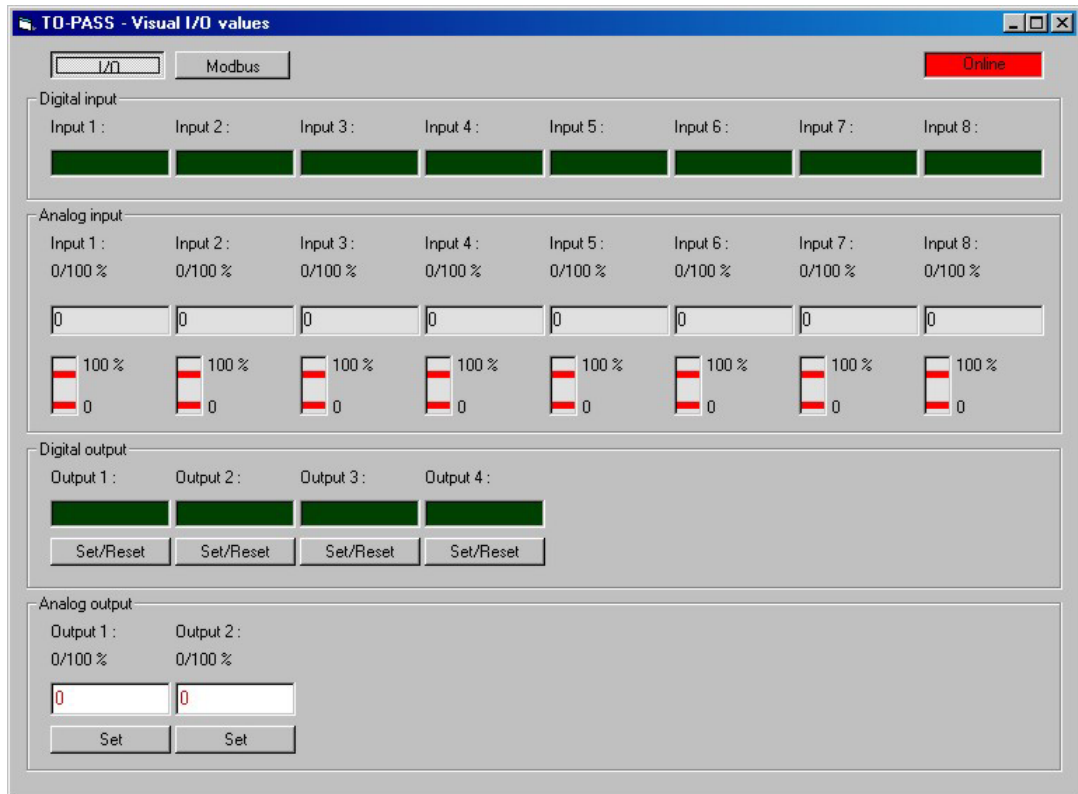

Figure 25: Visualization of the process values

Press the **[I/O]** button to display the process values of the digital and analog inputs and outputs. The process values displayed are valid if the on-line display is green.

Process values pertaining to digital and analog inputs are displayed in the upper portion of the window and those pertaining to digital outputs are displayed in the lower portion of the window.

You can set or reset the digital outputs by pressing the buttons **[Set/Reset]**.

11.3 Acknowledge Fault Messages

If a waiting time not equal to 0 has been set for the acknowledgment of fault messages, then the *TO-PASS*[®] S telecontrol module expects an acknowledgment of fault messages from the receiver.

The acknowledgment occurs via a simple call to the *TO-PASS*[®] S telecontrol module.

Select the *TO-PASS*[®] S telecontrol module and the connection is established after 2 or 3 ring signals. Finally, the connection to the *TO-PASS*[®] S telecontrol module is interrupted. The fault message is thus acknowledged. In addition, the *TO-PASS*[®] S telecontrol module sends an SMS with the text “Quit”.

NOTE:**Waiting time**

When the *TO-PASS*[®] S telecontrol module waits for an acknowledgment it is inactive for other tasks. Both the “Run” and “Busy” LEDs also light up. During the waiting time no messages are sent and no commands are accepted.

If the message is not acknowledged within the waiting time set, then the *TO-PASS*[®] S telecontrol module sends the fault message automatically to the next receiver entered under addresses and waits again for the defined waiting time for an acknowledgment.

If none of the receivers defined acknowledge the fault message and the number of repetitions is not set to 0, then the procedure is repeated until one receiver acknowledges the fault message or the maximum number of repetitions has been reached.

11.4 Switch Stand-by State

NOTE:**Stand-by state authorization**

Switching the ready state on and off is only possible by subscribers whose telephone number has been entered in the address list!

Using the “Standby” function, it is optional to change all messages sent by the *TO-PASS*[®] S telecontrol module specifically to the respective standby state. This takes place with simple changeover via SMS.

To do this, send an SMS with the text “Standby1” to the *TO-PASS*[®] S telecontrol module. The *TO-PASS*[®] S telecontrol module then transmits all alarm messages to the SMS sender. Other receivers defined in the *TO-PASS*[®] S telecontrol module are no longer informed.

In order to switch this function off send an SMS with the text “Standby0” to the *TO-PASS*[®] S telecontrol module.

12 Diagnostics

12.1 Test Inputs and Outputs

To test the inputs and outputs select the menu option **Controller > Test I/O**. The following window is displayed:

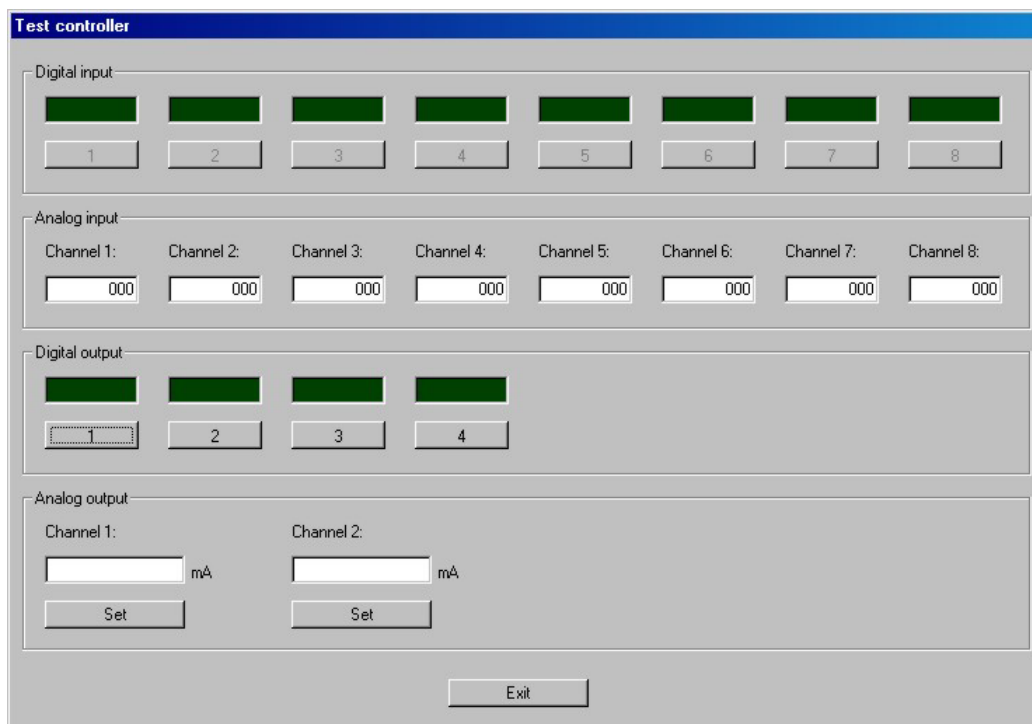

Figure 26: Test inputs and outputs

The states of the digital and analog inputs are displayed in the upper region. By pressing the buttons [1] ... [4] in the upper region switch digital inputs on and off.

Press the [Exit] button to end the test and close the window.

Alternatively, the inputs and outputs can also be tested with the help of the menu option **Visual > I/O values**.

12.2 Test the Connection

To test the connection, select the menu option **Controller > Test SMS/GPRS**. The following window is displayed:

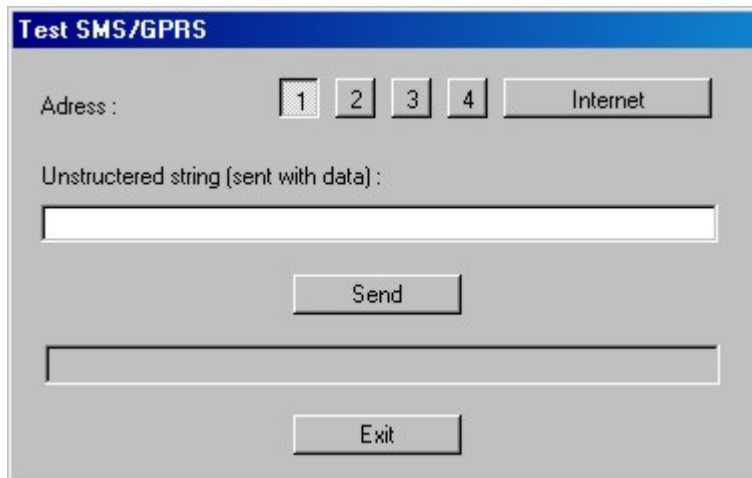

Figure 27: Test the connection

Select the address to send an SMS and enter the text to be sent. Press the **[Send]** button to send the message. The status of the transmission is finally displayed.

Press the **[Exit]** button to end the test and close the window.

12.3 Test the Modem

To test the link, select the menu option **Modem > Test**. The following window is displayed:

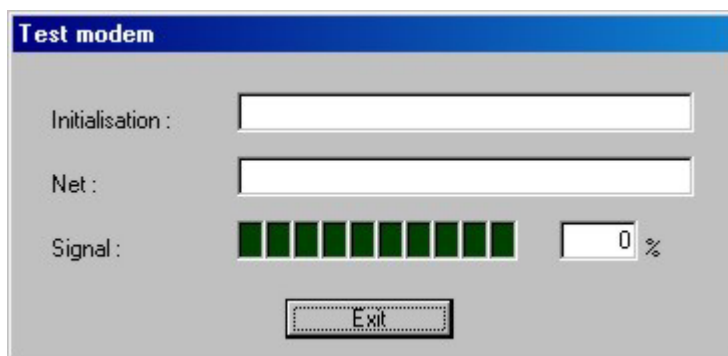

Figure 28: Modem test

Connection is established and the signal strength is displayed.

Press the **[Exit]** button to end the test and close the window.

13 WAGO-TO-PASS® Web

GPRS data records V1.50

13.1 Set Parameters

Select the *TO-PASS*® S telecontrol module to be configured from the project tree. Select the option **Addresses** to enter the parameters for transferring data to a web server.

You can use the WAGO server to test your application. For this purpose, please enter the values shown in table in chapter 10.4.

Select the entry **Refresh times** under the option **Special functions** and set the **WEB cycle time** of the cyclic transmission to the server, e.g. 5 minutes.

The communication as SMS or to the server can be tested under the menu option **Controller > Test SMS/GPRS**. Press the **[Internet]** button and enter any text, such as, e.g. "TEXT" in the field **Unstructured Text**. Then press the **[Send]** button. The reply "Web Refresh = 0" should follow after approx. 20 seconds.

Now go to the Web address www.to-pass.com and press the **[MyTO-PASS]** button.

Enter the user name as "test" and also the password as "test" and press the **[Login]** button.

Select your *TO-PASS*® S telecontrol module from the list and press the **[Display]** button.

13.2 Web Refresh

The HTTP method “POST” transmits the process image of the *WAGO TO-PASS*® telecontrol module to the Internet. A data record consists of from data in the context of the request.

All data are transmitted as strings (ASCII characters) having a fixed length.

13.2.1 Data Format

Table 15: Data format Web Refresh

Index	Variable	List of contents	Format
0	IS	Identity	Identity[8];Serial number[5]
1	PA	Parameter	Cycle time[4];Provider[5];Alarm Counter[2]
2	TI	Date, Time	YY/MM/DD,hh:mm:ss
3	D1	Digital input 1	Value;Alarm
4	D2	Digital input 2	Value;Alarm
5	D3	Digital input 3	Value;Alarm
6	D4	Digital input 4	Value;Alarm
7	D5	Digital input 5	Value;Alarm
8	D6	Digital input 6	Value;Alarm
9	D7	Digital input 7	Value;Alarm
10	D8	Digital input 8	Value;Alarm
11	A1	Analog input 1	Value[6];Unit[5];Alarm
12	A2	Analog input 2	Value[6];Unit[5];Alarm
13	A3	Analog input 3	Value[6];Unit[5];Alarm
14	A4	Analog input 4	Value[6];Unit[5];Alarm
15	A5	Analog input 5	Value[6];Unit[5];Alarm
16	A6	Analog input 6	Value[6];Unit[5];Alarm
17	A7	Analog input 7	Value[6];Unit[5];Alarm
18	A8	Analog input 8	Value[6];Unit[5];Alarm
19*	US	Sub-structured string	Data[40]
20**	EMPL	Modbus-Alarm	Value[2];Status[2];Alarm
21**	MV	Modbus variables	64 x Value[4];

* The variable is sent only if a Web refresh occurs via serial interface.

** The variables are sent only if Modbus is switched on.

NOTE:



Alarm flags with multiplex function

If the multiplex function is used then all alarm flags from D1 to D4 are ‘1’ for a multiplex alarm.

13.2.2 Response

The response to the request contains a string and optionally the time of the server.

The server time adjusts the time of the *WAGO TO-PASS*® telecontrol module.

The response string must be located within the first 250 characters of the HTML page (incl. HTTP header).

“Values stored”

Date and time are optional and are required only if the time of the *WAGO TO-PASS*® telecontrol module is to be set via server.

“Values stored:YY/MM/DD,hh:mm:ss”

The server can also report that the data was not accepted if, for example, a *WAGO TO-PASS*® telecontrol module is connected and the operator has made an incorrect input.

“Values not stored”

13.2.3 Example (Request)

```
ID=TopasM01;12345
PA=0060;26201;99          (□ Cycle time= 60 min, registered at T-
D 1,                       □ another 99 alarms are possible)
TI=05/12/02,14:27:59
D1=0;0
D2=1;0
D3=1;1                    (this value has triggered an alarm)
D4=0;0
D5=0;0
D6=0;0
D7=0;0
D8=0;0
A1= 0.123;bar ;0
A2= 25.40;degree ;0
A3= 71.50;degree ;0
A4= 0.000;mA ;0
A5= 0.000;mA ;0
A6=-0.000;mA ;0
A7=-0.000;mA ;0
A8=-0.000;mA ;0
US=Hello you there !
MA=00;00;0
MV=0000;0001;0002;0003; ... 0063
```

Example (Response):

Values stored:05/12/02,14:28:05

13.3 WebLog

In addition to Web Refresh the data records of the data and event loggers can also be sent to a script of the server. One packet contains 10 compressed data records of 14 bytes each.

13.3.1 Data format

Table 16: Data format WebLog

Index	Variable	List of contents	Format
0	IS	Identity	Identity[8];Serial number[5]
1	PA	Parameter	Cycle time[4];Provider[5];Alarm Counter[2]
2	TI	Date, Time	YY/MM/DD, hh:mm:ss
3	LO	Data sets of teh Logger	Log[140]

13.3.2 Data Format of a Data Record

```

Byte: 0      1      2      3      4      5      6
Bit:  76543210765432107654321076543210765432107654321076543210
Cnt.: PNNNNNNNSJJJJMMMMDDDDHhhhhmmmmmmsssssDIN.....AIN1.....

```

```

Byte: 7      8      9      10     11     12     13
Bit:  76543210765432107654321076543210765432107654321076543210
Cnt.: AIN2.....AIN3.....AIN4.....AIN5.....AIN6.....AIN7.....AIN8.....

```

P: Pointer for the next data set to be saved

NNNNNNN: Event number

S: Data records already sent

YYYY: Year

DDDDD: Day

MMMM: Month

hhhhh: Hour

mmmmm: Minute

sssss: Second

DIN.....: Digital inputs

AINx.....: Analog input channel x (x = 1 ... 8)

13.3.3 Use

The reception must be acknowledged with “Values stored” (refer to Web Refresh).

The data records must be decompressed on the server.

The data records with the bits set P=1 or S=1 are invalid and must be deleted.

The data records on the server must be sorted with respect to date/time.

14 Disclaimer

TO-PASS[®] Telecontrol Modules communicate using the GSM network (Global System for Mobile Communication). Exemptions cannot be made for GSM services used by the *TO-PASS*[®] telecontrol modules as they may be exposed to faults in the service provider's network. WAGO Kontakttechnik GmbH & Co. KG has no involvement with these types of problems.

Therefore, WAGO Kontakttechnik GmbH & Co. KG will reject any guarantee for the implementation of commands transmitted from and received by the *TO-PASS*[®] telecontrol module.

15 Technical Data

Table 17: Technical data Inputs

Number of inputs	Digital 4 (5 V ... 24 V) Analog 8 (0/4 mA ... 20 mA)
Input voltage digital inputs (24 V) _{max.}	1.6 mA
Interior resistance analog inputs	250 Ω

Table 18: Technical data Outputs

No. of outputs	Digital: 4 contacts Analog: 2 (0/4 mA ... 20 mA)
Load of digital outputs	AC/DC 60 V/1 A

Table 19: Technical data General

Number of recipients	4 (PC, SMS, e-mail, phone, fax)
Communication	GSM Quadband
Communication types	SMS (bidirectional), DFÜ selection connection (CSD), GPRS connection to Internet
Operating voltage	DC 8 V ... 36 V
Closed current	40 mA
Current during transmission	< 600 mA
Type of mounting	TS 32 DIN rail
Wire connection	Spring type connection
Dimensions (W x H x D)	109 mm x 105 mm x 78 mm
Weight approx.	426 G
Operating temperature	-20 °C ... +70°C
Storage temperature	-20 °C ... +70°C
Degree of protection	IP20
EMC 1 Immunity to interference	in acc. with EN 61000-4-6 (2001)

List of Figures

Figure 1: Front view	13
Figure 2: Terminal assignment for operating voltage	16
Figure 3: Terminal assignment for digital inputs	16
Figure 4: Terminal assignment for analog inputs.....	17
Figure 5: Terminal assignment for digital outputs	17
Figure 6: Terminal assignment for analog outputs.....	18
Figure 7: Antenna connection	18
Figure 8: PC Interface	19
Figure 9: Example of connection for switch at input DI1	20
Figure 10: Example of connection of transducer at input AI1	20
Figure 11: Example of connection of relay at output DO1	21
Figure 12: Display Elements	22
Figure 13: General settings.....	25
Figure 14: Configuring the identity.....	27
Figure 15: Configuring the addresses.....	28
Figure 16: Configuring the digital inputs.....	30
Figure 17: Configuring the multiplex settings	31
Figure 18: Configuring the multiplex alarm texts	32
Figure 19: Configuring the analog inputs.....	33
Figure 20: Configuring the digital outputs.....	35
Figure 21: Configuring the acknowledgment response.....	37
Figure 22: Configuring the transmission repeat times	38
Figure 23: Setting the time adjustment.....	39
Figure 24: Visualization of the process values.....	42
Figure 25: Visualization of the process values.....	44
Figure 26: Test inputs and outputs	47
Figure 27: Test the connection	48
Figure 28: Modem test	48

List of Tables

Table 1: Personnel Qualification.....	5
Table 2: Font Conventions	10
Table 3: Number Notation.....	10
Table 4: Products.....	12
Table 5: Terminal assignment for operating voltage.....	16
Table 6: Terminal assignment for digital inputs	16
Table 7: Terminal assignment for analog inputs	17
Table 8: Terminal assignment for digital outputs	17
Table 9: Terminal assignment for analog outputs.....	18
Table 10: PC Interface.....	19
Table 11: Interface cable allocation	19
Table 12: Display Elements	22
Table 13: SMS installation	41
Table 14: Example of parameter for Set DO.....	43
Table 15: Data format Web Refresh.....	50
Table 16: Data format WebLog.....	52
Table 17: Technical data Inputs	55
Table 18: Technical data Outputs.....	55
Table 19: Technical data General.....	55

WAGO Kontakttechnik GmbH & Co. KG
P.O. Box 2880 • D-32385 Minden
Hansastraße 27 • D-32423 Minden
Phone: 05 71/8 87 – 0
Fax: 05 71/8 87 – 1 69
E-Mail: info@wago.com

Web: <http://www.wago.com>

