

WAGO I/O SYSTEM FIELD

2-Channel Analog Output; IO-Link Converter; 4 ... 20 mA;
2 x M12 Connector

765-2703/200-000



Table of Contents

Provisions	4
1.1 Intended Use	4
1.2 Typographical Conventions.....	5
1.3 Legal Information	7
Safety	8
2.1 General Safety Rules	8
2.2 Electrical Safety.....	8
2.3 Mechanical Safety.....	8
2.4 Indirect Safety	8
2.5 Thermal Safety	9
Overview	10
Properties	11
4.1 View.....	11
4.2 Indicators.....	12
4.3 Connections	13
4.3.1 IO-Link Side.....	13
4.3.2 Actuator Side	13
4.4 Dimensional Drawings.....	14
4.5 Circuit Diagram.....	15
4.6 Technical Data	16
Functions	17
5.1 Operating Modes.....	17
5.1.1 IO-Link Mode	17
5.2 Parameter Description.....	17
5.2.1 Default Command	17
5.2.2 Device Access.....	18
5.2.3 Manufacturer	18
5.2.4 Manufacturer Text	18
5.2.5 Product Name	19
5.2.6 Product ID	19
5.2.7 Product Text	19
5.2.8 Serial Number	19
5.2.9 Hardware Version.....	20
5.2.10 Firmware Version	20
5.2.11 Application-Specific Attribute.....	20
5.2.12 Function Tag	21
5.2.13 Location Tag.....	21
5.3 Process Image	22
5.3.1 Input Process Data	22
5.3.2 Output Process Data	22

5.3.3	Representation of the Current Value on the Output	23
Planning		24
6.1	Structure Guidelines	24
6.1.1	Overcurrent Protection	24
6.1.2	EMC Installation	24
6.1.3	Connection Example	25
6.2	Behavior in the Event of a Communication Interruption	25
6.3	Examples and Aids	25
6.3.1	Aids	25
Installation and Removal		26
7.1	Mounting	26
7.1.1	Mounting the Product on a Mounting Clip	26
Connection		27
8.1	Connecting the Plug	27
Commissioning		28
9.1	Configuration and Parameterization	28
Transport and Storage		29
Diagnostics		30
11.1	Diagnostics via Indicators	30
11.2	Diagnostics via IO-Link	30
11.2.1	Diagnostics	30
11.2.2	Detailed Diagnostics	30
11.2.3	Active Events	31
11.2.4	Parameter Setting Errors	31
11.2.5	Error Types	32
11.2.6	Events	32
Decommissioning		34
12.1	Disposal and Recycling	34
Appendix		35
13.1	Installation Regulations Specified by Approvals	35
13.2	Accessories	35
13.3	Protected Rights	35
13.4	Technical Data, Approvals, Guidelines and Standards	36

Provisions

This document applies to the following product:

 **765-2703/200-000** (2AO FLD IOL CONV 4-20mA) 2-Channel Analog Output; IO-Link Converter; 4 ... 20 mA; 2 x M12 Connector

Product detail page

 www.wago.com/765-2703/200-000

The product must only be installed and operated in accordance with the operating instructions. Knowledge of the operating instructions is required for proper use. You can find all documents and information on the detailed product page.

Additional document

-  **WAGO IO-Link Configurator**

1.1 Intended Use

The product 765-2703/200-000 controls a connected actuator or another device that has an analog input within the output range from 4 to 20 mA.

- The product is intended for indoor use.
- Operation of the product in other application areas is only permitted when corresponding approvals and labeling are present.

Improper Use

Improper use of the product is not permitted. The following cases in particular constitute improper use:

- Non-observance of the intended use
- Use without protective measures in an environment in which salt water, salt spray mist, icing, corrosive fumes, explosive gases, direct sunlight and ionizing radiation can occur
- Use of the product in areas with special risk that require continuous fault-free operation and in which failure of or operation of the product can result in an imminent risk to life, limb or health or cause serious damage to property or the environment (such as the operation of nuclear power plants, weapons systems, aircraft and motor vehicles)

Warranty and Liability

The terms set forth in the General Business and Contract Conditions for Delivery and Service of WAGO GmbH & Co. KG and the terms for software products and products with integrated software stated in the WAGO Software License Contract – both available at

 www.wago.com – shall apply. In particular, the warranty is void if:

- The product is improperly used.
- The deficiency (hardware and software configurations) is due to special instructions.
- Modifications to the hardware or software have been made by the user or third parties that are not described in this documentation and that has contributed to the fault.

Individual agreements always have priority.

Obligations of Installers/Operators

The installers and operators bear responsibility for the safety of an installation or a system assembled with the products. The installer/operator is responsible for proper installation and safety of the system. All laws, standards, guidelines, local regulations and accepted technology standards and practices applicable at the time of installation, and the instructions in the the products' Instructions for Use, must be complied with. In addition, the Installation regulations specified by Approvals must be observed. In the event of non-compliance, the products may not be operated within the scope of the approval.

1.2 Typographical Conventions





Number Notation

100	Decimals: Normal notation
0x64	Hexadecimals: C-notation
'100'	Binary: In single quotation marks
'0110.0100'	Nibbles separated by a period

Text Formatting

<i>italic</i>	Names of paths or files
bold	Menu items, entry or selection fields, emphasis
Code	Sections of program code
>	Selection of a menu point from a menu
"Value"	Value entries
[F5]	Identification of buttons or keys

Cross References / Links

	Cross references/links to a topic in a document
	Cross references / links to a separate document
	Cross references / links to a website
	Cross references / links to an email address

Action Instructions

- ✓ This symbol identifies a precondition.
- 1. Action step
- 2. Action step
 - ⇒ This symbol identifies an intermediate result.
 - ⇒ This symbol identifies the result of an action.
- Individual action step

Lists

- Lists, first level
 - Lists, second level

Figures

Figures in this documentation are for better understanding and may differ from the actual product design.

Notes

DANGER

Type and source of hazard

Possible consequences of hazard that also include death or irreversible injury

- Action step to reduce risk

WARNING

Type and source of hazard

Possible consequences of hazard that also include severe injury

- Action step to reduce risk

CAUTION

Type and source of hazard

Possible consequences of hazard that include at least slight injury

- Action step to reduce risk

NOTICE

Type and source of malfunction (property damage only)

Possible malfunctions that may restrict the product's scope of functions or ergonomics, but do not lead to foreseeable risks to persons

- Action step to reduce risk

Note

Notes and information

Indicates information, clarifications, recommendations, referrals, etc.

1.3 Legal Information

Intellectual property

The intellectual property of this document belongs to WAGO GmbH & Co. KG. The reproduction and distribution of its content (in whole or in part) is prohibited, unless otherwise provided by statutory provisions, written agreements or this document. In case of doubt, the written consent of WAGO GmbH & Co. KG must be obtained in advance.

Third-party products are always mentioned without any reference to patent rights. WAGO GmbH & Co. KG, or the manufacturer of third-party products, retains all rights regarding patent, utility model or design registration.

Third-party trademarks are referred to in the product documentation. The “®” and “TM” symbols are omitted hereinafter. The trademarks are listed in the Appendix:  **Protected Rights [▶ 35]**.

Subject to Change

The instructions, guidelines, standards, etc., in this manual correspond to state of the art at the time the documentation was created and are not subject to updating service. The installer and operator bear sole responsibility to ensure they are complied with in their currently applicable form. WAGO GmbH & Co. KG retains the right to carry out technical changes and improvements of the products and the data, specifications and illustrations of this manual. All claims for change or improvement of products that have already been delivered – excepting change or improvement performed under guarantee agreement – are excluded.

Licenses

The products may contain open-source software. The requisite license information is saved in the products. This information is also available under:  www.wago.com.

Safety

2.1 General Safety Rules

- This documentation is part of the product. Therefore, retain the documentation during the entire service life of the product. Pass on the documentation to any subsequent user of the product. In addition, ensure that any supplement to this documentation is included, if necessary.
- The product must only be installed and put into operation by qualified electrical specialists per EN 50110-1/-2 and IEC 60364.
- Comply with the laws, standards, guidelines, local regulations and accepted technology standards and practices applicable at the time of installation.

2.2 Electrical Safety

- Disconnect all power sources from the product before performing any installation, repair or maintenance.
- Make sure the product does not carry any voltage before starting work.

Power Supply

- Connecting impermissible current or frequency values may destroy the product.

Grounding/Protection/Fuses

- When handling the product, please ensure that environmental factors (personnel, work space and packaging) are properly equalized. Do not touch any conducting parts.
- The product does not contain internal overcurrent protection. Protect the product with an appropriate overcurrent protection device.

Cables

- Use appropriate strain relief.

2.3 Mechanical Safety

- Before startup, please check the product for any damage that may have occurred during shipping. Do not put the product into operation in the event of mechanical damage.
- Do not open the product housing.

2.4 Indirect Safety

- Only use a dry or cloth or a clothed dampened with water to clean the product. Do not use cleaning agents, e.g., abrasive cleaners, alcohols or acetone.
- Only permit skilled personnel approved by WAGO to perform repair work.
- Replace any defective or damaged devices.
- Use only UL-approved category CYJV 2/7/8 cables to connect the product in UL-approved systems.
- Only use accessories authorized by WAGO.

2.5 Thermal Safety

- Observe permissible temperature range of connecting cables.
- The conductor cross-sections must be designed for the maximum load current.

Overview

The Analog/IO-Link Converter provides an economical, compact solution for easily incorporating conventional analog sensors and actuators into an IO-Link-capable system like the WAGO I/O System Field, depending on their type. This allows reliable, cost-effective, interference-immune acquisition and output of analog signals. Digital communication can easily be introduced (retrofitted) when old systems are modernized. The converter can be configured via IO-Link. A compact design, IP67 protection and the high operating temperature range make the Analog/IO-Link Converter ideal for automation without control cabinets.

This product controls a connected actuator or another device that has an analog input. The product has two analog current inputs.

The product functions as an "IO-Link/analog converter."

Properties

4.1 View

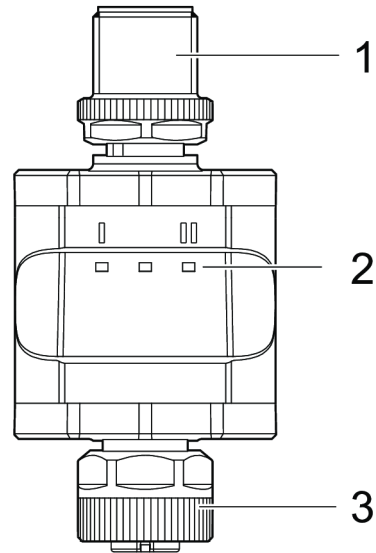

Figure 1: View

Table 1: Legend for Figure "View"

No.	Custom Name	
1	M12 A plug	IO-Link Side [▶ 13]
2	LEDs	Indicators [▶ 12]
3	M12 A socket	Actuator Side [▶ 13]

4.2 Indicators

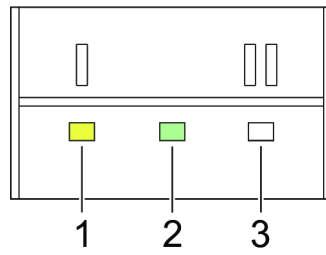

Figure 2: Indicators – LEDs

Table 2: Legend for Figure “Indicators – LEDs”

No.	LED	Color
1	I OUT1	Yellow
2	POWER	Green
3	II OUT2	Yellow

4.3 Connections

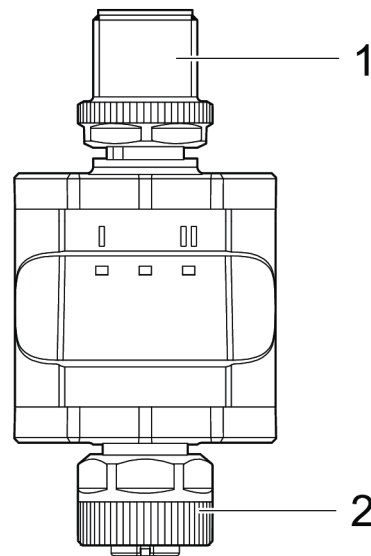



Figure 3: Connections

Table 3: Legend for Figure "Connections"

No.	Custom Name	
1	IO-Link side (M12 A plug)	IO-Link Side [► 13]
2	Actuator side (M12 A socket)	Actuator Side [► 13]

4.3.1 IO-Link Side

Table 4: IO-Link Side (M12 A Plug)

Connection	Pin	Signal	Description
 M12 A plug, 4-pole	1	1L+	24 VDC supply
	2	-	Not assigned
	3	1L-	0 V power supply
	4	C/Q	IO-Link

4.3.2 Actuator Side

Table 5: Actuator Side (M12 A Socket)

Connection	Pin	Signal	Description
 M12 A socket, 5-pole	1	1L+	Actuator supply
	2	AO 4 ... 20 mA	Analog output 2
	3	1L-	Actuator supply
	4	AO 4 ... 20 mA	Analog output 1
	5	-	Not assigned

4.4 Dimensional Drawings

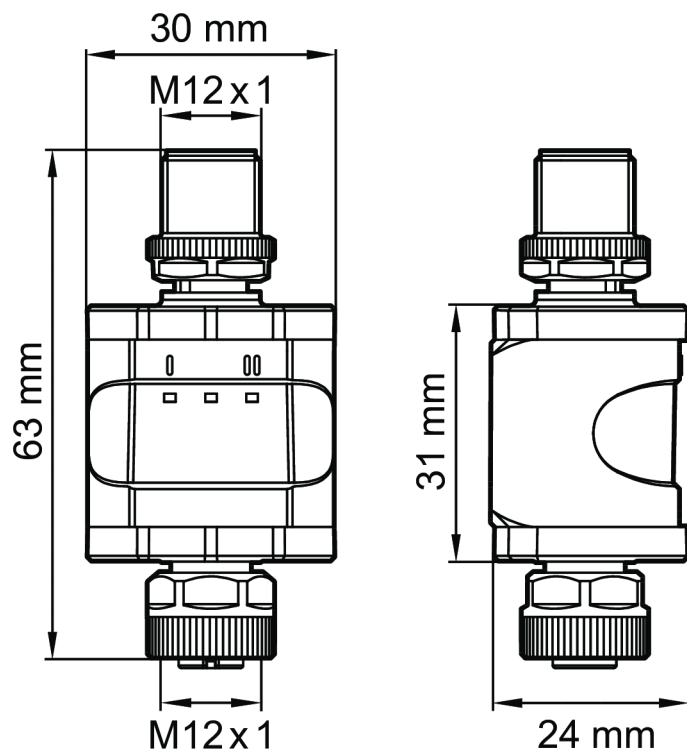

Figure 4: Dimensional Drawings

4.5 Circuit Diagram

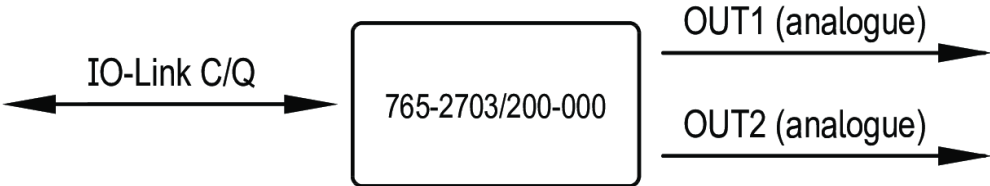

Figure 5: Circuit Diagram

4.6 Technical Data

Note

Read technical data sheet!



You can find technical data on the product in the appendix under  **Technical Data, Approvals, Guidelines and Standards [▶ 36]**.

Table 6: Technical Data – Communication

Name	Value	Remark
Manufacturer ID	285 / 0x011D Bytes 01 29 / 0x01 0x1D	If the manufacturer ID and device ID are specified in the PLC system, this ensures that: <ul style="list-style-type: none"> • The right product is connected • The IO-Link data management works • Operation of your application will still be possible even if the product is replaced by a successor model at a later date.
Device ID	8391311 / 0x800A8F Bytes 128 10 143 / 0x80 0x0A 0x8F	
Manufacturer	WAGO GmbH & Co. KG	
Manufacturer text	WAGO IO-Link Converter	
Manufacturer URL	 https://www.wago.com/765-2703/200-000	
IO-Link revision	V1.1	
Bit rate	COM2	
Minimum cycle time	3.6 ms	
SIO mode supported	No	
Block parameterization	Yes	
Data management	Yes	

Functions

5.1 Operating Modes

5.1.1 IO-Link Mode

IO-Link is a communication system for connecting intelligent sensors and actuators to automation systems. IO-Link is governed by the IEC 61131-9 standard.

The product has an IO-Link communication interface that requires an IO-Link-capable module (IO-Link master) for interoperation.

The IO-Link interface allows direct access to the process data and diagnostic data and allows product parameters to be set during operation.

For more information about IO-Link and all the necessary information about the required IO-Link hardware and software, see www.wago.com/<item number>.

IO Device Description (IODD)

The IODD (Input Output Device Description) required for configuration can be downloaded from the IO-Link community's website: www.io-link.com.

5.2 Parameter Description

Parameters are set through the ISDU mechanism (ISDU = Indexed Service Data Units) described in the IO-Link specification. This allows read and write access to the ISDU objects.

The product is parameterized via an IO-Link tool (e.g., WAGO IO-Link Configurator),

The terms "index" and "subindex" used in the following tables refer to Indexed Service Data Units (ISDUs).

The following parameters are available.

You can find product diagnostic parameters in [🔒 Diagnostics via IO-Link \[▶ 30\]](#).

5.2.1 Default Command

Table 7: Default Command – General

Index	2
Access rights	Write-only

Table 8: Default Command

Name	Description	Subindex	Data Type	Length	Factory Setting	Value Range
Default command	-	0	UIntegerT	8 bits	-	(130) Restore factory default (240) IO-Link 1.1 system test command 240, event 8DFE appears

Name	Description	Subindex	Data Type	Length	Factory Setting	Value Range
						(241) IO-Link 1.1 system test command 241, event 8DFE disappears
						(242) IO-Link 1.1 system test command 242, event 8DFF appears
						(243) IO-Link 1.1 system test command 243, event 8DFF disappears
						(255) Command with no effect – for internal use only

5.2.2 Device Access

Table 9: Variables – Device Access – General

Index	12
Access rights	Read/write

Table 10: Variables – Device Access

Name	Description	Subindex	Data Type	Length	Factory Setting	Value Range
Device access blocks	-	0	RecordT	16 bits	-	-
Data management	-	bitOffs 1	BooleanT	1 bit	False	False (open) True (locked)

5.2.3 Manufacturer

Table 11: Variables – Manufacturer Name – General

Index	16
Access rights	Read-only

Table 12: Variables – Manufacturer Name

Name	Description	Subindex	Data Type	Length	Factory Setting	Value Range
Manufacturer	Manufacturer name assigned to a manufacturer ID	0	StringT	max. 18 bytes	WAGO GmbH & Co. KG	-

5.2.4 Manufacturer Text

Table 13: Variables – Manufacturer Text – General

Index	17
Access rights	Read-only

Table 14: Variables – Manufacturer Text

Name	Description	Subindex	Data Type	Length	Factory Setting	Value Range
Manufacturer text	Additional information on the manufacturer	0	StringT	max. 22 bytes	WAGO IO-Link Converter	-

5.2.5 Product Name

Table 15: Variables – Product Name – General

Index	18
Access rights	Read-only

Table 16: Variables – Product Name

Name	Description	Subindex	Data Type	Length	Factory Setting	Value Range
Product name	Full product name	0	StringT	max. 18 bytes	765-2703/200-000	-

5.2.6 Product ID

Table 17: Variables – Product ID – General

Index	19
Access rights	Read-only

Table 18: Variables – Product ID

Name	Description	Subindex	Data Type	Length	Factory Setting	Value Range
Product ID	Manufacturer-specific product or type identification (e.g., item number or order number)	0	StringT	max. 8 bytes	765-2703	-

5.2.7 Product Text

Table 19: Variables – Product Text – General

Index	20
Access rights	Read-only

Table 20: Variables – Product Text

Name	Description	Subindex	Data Type	Length	Factory Setting	Value Range
Product Text	Additional product information	0	StringT	27 bytes	2AO FLD IOL CONV 4-20mA	-

5.2.8 Serial Number

Table 21: Variables – Serial Number – General

Index	21
Access rights	Read-only

Table 22: Variables – Serial Number

Name	Description	Subindex	Data Type	Length	Factory Setting	Value Range
Serial number	Unique manufacturer-specific identifier of the individual product	0	StringT	12 bytes	-	-

5.2.9 Hardware Version

Table 23: Variables – Hardware Version – General

Index	22
Access rights	Read-only

Table 24: Variables – Hardware Version

Name	Description	Subindex	Data Type	Length	Factory Setting	Value Range
Hardware version	Unique manufacturer-specific identifier of the hardware version of the individual product	0	StringT	2 bytes	-	-

5.2.10 Firmware Version

Table 25: Variables – Firmware Version – General

Index	23
Access rights	Read-only

Table 26: Variables – Firmware Version

Name	Description	Subindex	Data Type	Length	Factory Setting	Value Range
Firmware Version	Unique manufacturer-specific identifier of the firmware version of the individual product	0	StringT	5 bytes	-	-

5.2.11 Application-Specific Attribute

Table 27: Variables – Application-Specific Attribute – General

Index	24
Access rights	Read/write

Table 28: Variables – Application-Specific Attribute

Name	Description	Subindex	Data Type	Length	Factory Setting	Value Range
Application-Specific Attribute	Option for tagging the product with user- or application-specific information	0	StringT	32 bytes	***	-

5.2.12 Function Tag

Function tag (customer-specific system ID), max. 32 characters long

Value: “ *** ” / freely definable by customer

Table 29: Variables – System Tag – General

Index	25
Access rights	Read/write

Table 30: Variables – System Tag

Name	Description	Subindex	Data Type	Length	Factory Setting	Value Range
Function Tag	Option for tagging the product with function-specific information	0	StringT	32 bytes	***	-

5.2.13 Location Tag

Location tag (customer-specific location ID), max. 32 characters long

Value: “ *** ” / freely definable by customer

Table 31: Variables – Location Tag – General

Index	26
Access rights	Read/write

Table 32: Variables – Location Tag

Name	Description	Subindex	Data Type	Length	Factory Setting	Value Range
Location Tag	Option for tagging the product with location-specific information	0	StringT	32 bytes	***	-

5.3 Process Image

i Note

Process data is shown from the product’s perspective!

The following process data is presented from the product’s perspective. Some controllers swap the high and low byte when addressing byte by byte.

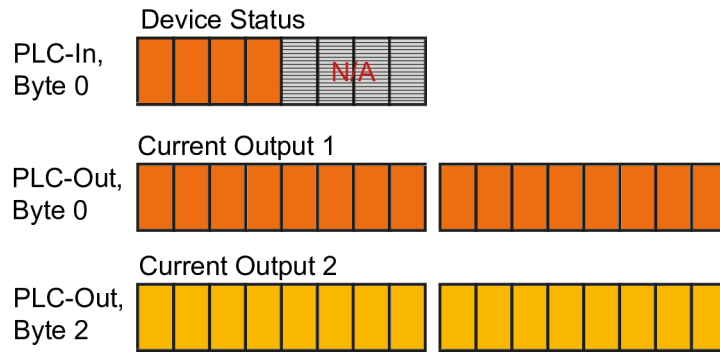

Figure 6: Input and Output Process Data

5.3.1 Input Process Data

Table 33: Input Process Data

Byte	Data Type (Bits)	Bit Offset	Content	Value Range	Description
0	UIntegerT (4)	4	Device status	0	OK
				1	Maintenance required
				2	Outside specification
				3	Function test
				4	Error

5.3.2 Output Process Data

Table 34: Output Process Data

Byte	Data Type (Bits)	Content	Value Range	Description	Factor	Offset	Unit
0	IntegerT (16)	Current current value Analog output 1	0 ... 22000	0 ... 22 mA	0.001	0	mA
2	IntegerT (16)	Current current value Analog output 2	0 ... 22000	0 ... 22 mA	0.001	0	mA

5.3.3 Representation of the Current Value on the Output

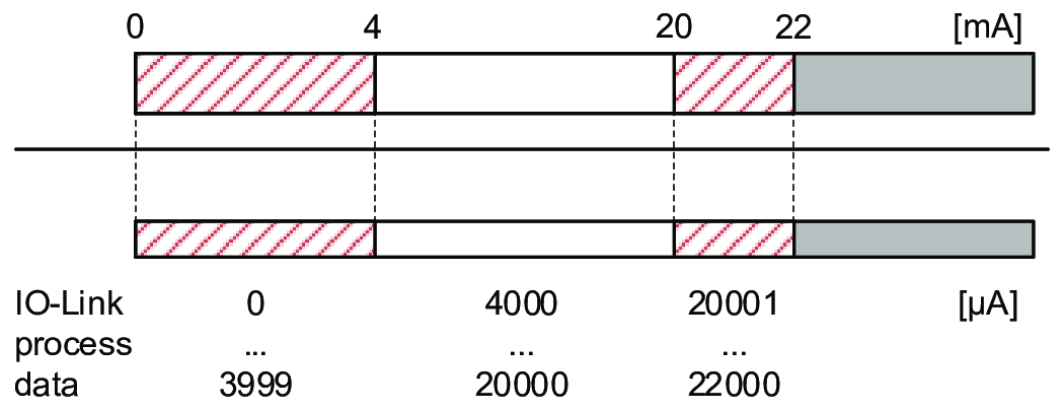

Figure 7: Analog Value Representation

Planning

6.1 Structure Guidelines

6.1.1 Overcurrent Protection

Protecting Circuits against Overcurrent

Protect the circuits by using a fuse.

Table 35: Protecting Circuits against Overcurrent

Potential	M12 A plug	Fuse
1L+ / power supply	Pin 1	≤2 A
C/Q IO-Link (if not fused via IO-Link master)	Pin 4	≤2 A

Required trip characteristics of the fuses:

$T_{fuse} \leq 120$ s at max. 6.25 A (fire protection)

Alternatively, the product can be powered by a limited-energy circuit per IEC 61010-1 or Class 2 per UL 1310.

CAUTION

The input current is unrestricted.

> no fire protection

- Protect circuits against overcurrent.

6.1.2 EMC Installation

- **Keep data and signal lines separate from interference sources.**

Route data and signal lines separately from all power supply cables and other sources of high electromagnetic emissions (e.g., frequency converters or drives).

- **Observe maximum cable lengths**

The maximum lengths of the connecting cables are as follows:

- With IO-Link communication on the product master side: 20 m

6.1.3 Connection Example

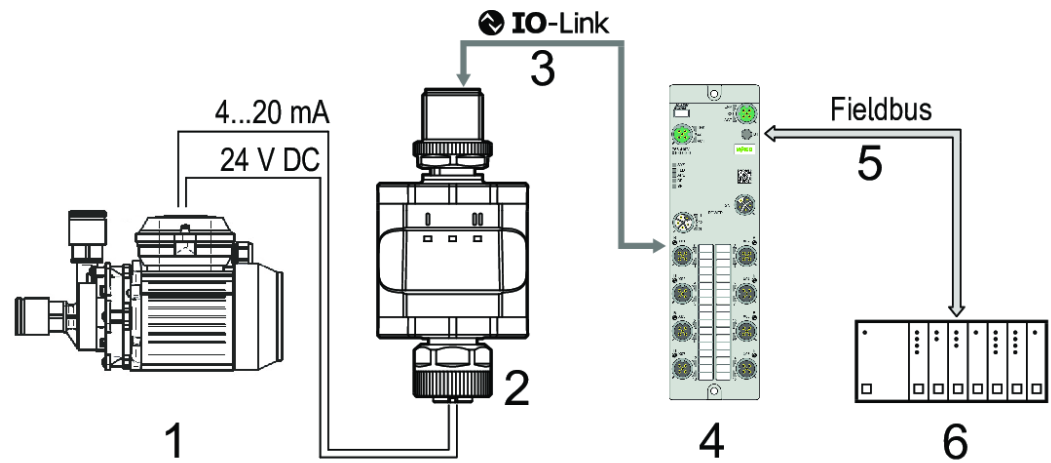

Figure 8: Connection Example with IO-Link Master

Table 36: Legend for Figure "Connection Example with IO-Link Master"

No.	Description
1	Analog actuator
2	WAGO Analog IO-Link Converter
3	Complete bidirectional IO-Link communication • Remote parameterization: Read and change parameter setting.
4	IO-Link master
5	Fieldbus (Profinet, EtherCAT, EtherNet/IP etc.)
6	PLC

6.2 Behavior in the Event of a Communication Interruption

In case of communication interruption, the transmitted values are delivered to ZERO.

6.3 Examples and Aids

6.3.1 Aids

The parameters are set with an I/O-Link tool, e.g., WAGO IO-Link Configurator.

You can obtain the WAGO IO-Link Configurator software, as well as the associated product manual with a detailed description of the software, from www.wago.com.

Installation and Removal

7.1 Mounting

7.1.1 Mounting the Product on a Mounting Clip

The product can be secured with a Mounting Clip.

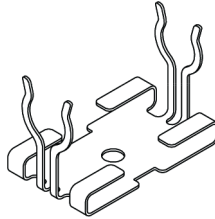

Figure 9: Mounting Clip (Secured with an M4 Screw or Cable Tie)

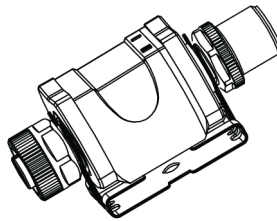

Figure 10: Mounting Clip with Product Attached

The Mounting Clip is not included upon delivery. You can find more information in [🔗 Accessories \[▶ 35\]](#).

Connection

8.1 Connecting the Plug

The mounting method must not cause mechanical stress on the M12 connection parts. Depending on the conditions of use, it may also be necessary to protect the product against mechanical stresses (shock/vibration) through appropriate mounting.

- ✓ The circuit must be protected by the use of a fuse or powered by a limited-energy circuit.

 1. Connect the pluggable connectors of the connecting cables to the product.
 2. Tighten the cap nut with a tightening torque of at least 1.0 Nm.

Note

External power supply to actuator side not allowed

No external power supply to the product is permitted at the 5-pin M12 output socket (actuator side).

Once the power supply is applied, the product is in the operating mode. It executes its output and evaluation functions and provides output signals according to the parameter settings (see Parameter Description).

Commissioning

i Note

Commissioning via parameter channel

The product is both commissioned and configured via the parameter channel.

You can find the individual parameters and additional information in [🔗 Parameter Description \[▶ 17\]](#).

9.1 Configuration and Parameterization

i Note

The product is in operating mode during parameterization

During the parameterization process, the product remains in operating mode. It continues to perform its monitoring functions with the existing parameters until the parameterization is completed.

Transport and Storage

The original packaging offers optimal protection during transport and storage.

- Store the product in suitable packaging, preferably the original packaging.
- Only transport the product in suitable containers/packaging.
- Make sure the product contacts are not contaminated or damaged during packing or unpacking.
- Observe the specified ambient climatic conditions for transport and storage.

Diagnostics

11.1 Diagnostics via Indicators

Table 37: Diagnostics via Indicators

LED	LED State	Explanation
I	On	The analog value is in the normal range: 0 ... 100 % (4 ... 20 mA)
	Flashing (2 Hz)	The analog value is in the range -10 ... 0 %, 100 ... 110 % (2 ... 4 mA, 20 ... 22 mA)
	Flashing (5 Hz)	The current loop is interrupted.
	Off	When the device is switched off, the analog value is < -10 % (<2 mA)
Power	On	The power supply is OK. The product is in operating mode.
	Flashing (5 Hz)	The product is underpowered.
	Off	There is no supply voltage.
II	On	The analog value is in the normal range: 0 ... 100 % (4 ... 20 mA)
	Flashing (2 Hz)	The analog value is in the range -10 ... 0 %, 100 ... 110 % (2 ... 4 mA, 20 ... 22 mA)
	Flashing (5 Hz)	The current loop is interrupted.
	Off	When the device is switched off, the analog value is < -10 % (<2 mA)

11.2 Diagnostics via IO-Link

11.2.1 Diagnostics

Table 38: Variables – Diagnostics – General

Index	36
Access rights	Read-only

Table 39: Variables – Diagnostics

Name	Description	Subindex	Data Type	Length	Factory Setting	Value Range
Device status	Indicates the current product and diagnostic state	0	UIntegerT	8 bits	0	0 (Product is OK)
						1 (Maintenance required)
						2 (Outside specification)
						3 (Function test)
						4 (Failure)
5 ... 255 (Reserved)						

11.2.2 Detailed Diagnostics

Table 40: Variables – Detailed Diagnostics – General

Index	37
Access rights	Read-only

Table 41: Variables – Detailed Diagnostics

Name	Description	Subindex	Data Type	Length	Factory Setting	Value Range [h]
Detailed device status	List of all currently pending events of the product	0	ArrayT	24 bytes	00 00 00	-

11.2.3 Active Events

Table 42: Variables – Active Events – General

Index	545
Access rights	Read-only

Table 43: Variables – Active Events

Name	Description	Subindex	Data Type	Length	Factory Setting	Value Range
Active Events	Bit mask for currently pending events	0	RecordT	32 bits	-	-
Bit_31	Test Event 2. Product status = 1 (Maintenance required)	bitOffset 31	Boolean T	1 bit	0	0 (noEv) 1 (0x8DFF)
Bit_30	Test Event 1. Product status = 1 (Maintenance required)	bitOffset 30	Boolean T	1 bit	0	0 (noEv) 1 (0x8DFE)
Bit_17	Load impedance for analog output too high	bitOffset 17	Boolean T	1 bit	0	0 (noEv) 1 (0x8CA5)
Bit_15	Permissible product temperature exceeded	bitOffset 15	Boolean T	1 bit	0	0 (noEv) 1 (0x4210)
Bit_8	Process value outside valid range	bitOffset 8	Boolean T	1 bit	0	0 (noEv) 1 (0x8C10)
Bit_4	Temperature error	bitOffset 4	Boolean T	1 bit	0	0 (noEv) 1 (0x4000)
Bit_1	Parameter error	bitOffset 1	Boolean T	1 bit	0	0 (noEv) 1 (0x6320)
Bit_0	Hardware fault in product	bitOffset 0	Boolean T	1 bit	0	0 (noEv) 1 (0x5000)

11.2.4 Parameter Setting Errors

Table 44: Variables – Parameter Setting Errors – General

Index	546
Access rights	Read-only

Table 45: Variables – Parameter Setting Errors

Name	Description	Subindex	Data Type	Length	Factory Setting	Value Range
Parameter setting error	Indicates the parameter that was set incorrectly at the time of download	0	ArrayT	10*32 bits	0	0 (OK) 786432 (DeviceAccessLocks)

11.2.5 Error Types

Table 46: Process Image – Error Types

Error Code	Name	Description
32785 d / 0x8011	Index does not exist	Access to an index that does not exist
32786 d / 0x8012	Subindex does not exist	Access to a subindex that does not exist
32800 d / 0x8020	Service is currently unavailable	The parameter cannot be accessed. The product does not allow this in its current state.
32801 d / 0x8021	Service currently unavailable – local operating mode	The parameter cannot be accessed, since the product is currently in local operating mode.
32802 d / 0x8022	Service currently unavailable – product operating mode	The parameter cannot be accessed, since the product is currently in remote operating mode.
32803 d / 0x8023	Access denied	Write access to a read-only parameter
32816 d / 0x8030	Parameter value outside valid range	The parameter value that was written is outside the permissible value range.
32819 d / 0x8033	Parameter length overrun	The length of the parameter that was written is greater than is allowed.
32820 d / 0x8034	Parameter length underrun	The length of the parameter that was written is less than is allowed.
32821 d / 0x8035	Function unavailable	The product does not support the command that was written
32822 d / 0x8036	Function currently unavailable	The product does not support the command that was written in the current state.
32832 d / 0x8040	Invalid parameter set	The individual parameter value that was written collides with the other parameter settings.
32833 d / 0x8041	Inconsistent parameter set	Inconsistencies were detected at the end of the block parameter transfer. The product plausibility check failed.
32898 d / 0x8082	Application not ready	Access was denied because the product is not currently ready.

11.2.6 Events

Table 47: Process Image – Events

Code	Device status	Name	Type	Description
16384 d 0x4000	4 (error)	Temperature error	Error	Overload
16912 d 0x4210	2 (Outside specification)	Permissible product temperature exceeded	Warning	Eliminate heat source
20480 d 0x5000	4 (error)	Hardware fault in product	Error	Replace product
25376 d 0x6320	3 (Function test)	Parameter error	Error	Check datasheet and values

Code	Device status	Name	Type	Description
35856 d 0x8C10	2 (Outside specification)	Process value outside valid range	Warning	Process value uncertain message: This event is not broadcast on the event channel. It can only be read out via index 37 (DetailedDeviceStatus) or 545 (BitCoded_ActiveEvents).
36005 d 0x8CA5	2 (Outside specification)	Load impedance for analog output too high	Warning	Check wiring
36350 d 0x8DFE	1 (Maintenance required)	Test event 1	Warning	Event appears when index 2 is set to value 240; event disappears when index 2 is set to value 241
36351 d 0x8DFF	1 (Maintenance required)	Test event 2	Warning	Event appears when index 2 is set to value 242; event disappears when index 2 is set to value 243

Decommissioning

12.1 Disposal and Recycling



WEEE Mark

Electrical and electronic equipment may not be disposed of with household waste. This also applies to products without this mark.

Electrical and electronic equipment contain materials and substances that can be harmful to the environment and health. Electrical and electronic equipment must be disposed of properly after use. Environmentally friendly disposal benefits health, protects the environment from harmful substances in electrical and electronic equipment and enables sustainable and efficient use of resources.

- Observe the national and local regulations for the disposal of electrical and electronic equipment, lithium-ion batteries, lead–acid batteries and packaging.
- Clear any data stored on electrical and electronic equipment.
- Remove lithium-ion batteries, lead–acid batteries or memory cards that are added to the electrical and electronic equipment.
- Wear appropriate personal protective equipment when removing the lithium-ion batteries/lead–acid batteries.
- Dispose of the removed lithium-ion batteries/lead–acid batteries according to your local waste regulations (e. g. collection boxes at the retail or local collection points).
- Have electrical and electronic equipment sent to a local collection point.
- Dispose of all types of packaging to ensure a high level of recovery, reuse and recycling.
- Transport packages from the B2B area can be taken back free of charge via a return system in accordance with the Packaging Act. Please contact our service provider Interseroh directly. The corresponding certificate can be found at: [🌐 corporate-certificates](#)
- Throughout Europe, Directives 2006/66/EC, 94/62/EC and 2012/19/EU (WEEE) apply. National directives and laws may differ.

Appendix

13.1 Installation Regulations Specified by Approvals

For the Scope of cULus:

Electricity can only be supplied by via SELV/PELV circuits. Device powered according to “Limited Energy” per UL 61010-1, chapter 9.4. External circuits must be isolated per UL 61010-2-201, figure 102.

The device is safe at least under the following conditions:

- Indoor use
- Altitude up to 2000 m
- Maximum relative humidity of 90 %, non-condensing
- Pollution degree 3
- Use UL-certified category CYJV 2/7/8 connection cables with suitable data to connect the device to the IO-Link devices.
- No evaluation of the IP class has been performed by UL.
- No special treatment is required when cleaning the device.

13.2 Accessories

Table 48: Accessories

Item No.	Product
765-101/000-000	Mounting Clip

13.3 Protected Rights

- Adobe® and Acrobat® are registered trademarks of Adobe Systems Inc.
- Android™ is a trademark of Google LLC.
- Apple, the Apple logo, iPhone, iPad and iPod touch are registered trademarks of Apple Inc. registered in the USA and other countries. “App Store” is a service mark of Apple Inc.
- AS-Interface® is a registered trademark of the AS-International Association e.V.
- BACnet® is a registered trademark of the American Society of Heating, Refrigerating and Air Conditioning Engineers, Inc. (ASHRAE).
- Bluetooth® is a registered trademark of Bluetooth SIG, Inc.
- CiA® and CANopen® are registered trademarks of CAN in AUTOMATION – International Users and Manufacturers Group e.V.
- CODESYS is a registered trademark of CODESYS Development GmbH.
- DALI is a registered trademark of the Digital Illumination Interface Alliance (DiiA).
- EtherCAT® is a registered trademark and patented technology licensed by Beckhoff Automation GmbH, Germany.
- ETHERNET/IP™ is a registered trademark of the Open DeviceNet Vendor Association, Inc (ODVA).
- EnOcean® is a registered trademark of EnOcean GmbH.
- Google Play™ is a registered trademark of Google Inc.
- IO-Link is a registered trademark of PROFIBUS Nutzerorganisation e.V.
- KNX® is a registered trademark of the KNX Association cvba.

- Linux® is a registered trademark of Linus Torvalds.
- LON® is a registered trademark of the Echelon Corporation.
- Modbus® is a registered trademark of Schneider Electric, licensed for Modbus Organization, Inc.
- OPC UA is a registered trademark of the OPC Foundation.
- PROFIBUS® is a registered trademark of the PROFIBUS Nutzerorganisation e.V. (PNO).
- PROFINET® is a registered trademark of the PROFIBUS Nutzerorganisation e.V. (PNO).
- QR Code is a registered trademark of DENSO WAVE INCORPORATED.
- Subversion® is a trademark of the Apache Software Foundation.
- Windows® is a registered trademark of Microsoft Corporation.

13.4 Technical Data, Approvals, Guidelines and Standards

See also

 [Data_sheet_765-2703/200-000](#) [▶ 37]

Note

Subject to changes!

Please also observe the further product documentation! You can generate the current datasheet at any time at: www.wago.com /<item number>.

13.4.1 Data_sheet_765-2703/200-000

765-2703/200-000

2-Channel Analog Output; IO-Link Converter; 4 ... 20 mA; 2 x M12 Connection



M12-A plug; 4-pole

- 1: 24 VDC: Supply 1L+
- 2: not used
- 3: 0 V: Supply 1L-
- 4: C/Q IO-Link



M12-A socket; 5-pole

- 1: Actuator supply 1L+
- 2: Analog output 2 (4 ... 20 mA)
- 3: Actuator supply 1L-
- 4: Analog output 1 (4 ... 20 mA)
- 5: not used

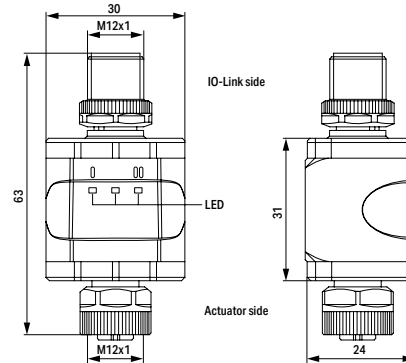

Application:
Decentralized preprocessing and output of analog signals

This device controls a connected actuator or any other unit that has an analog input (4 ... 20 mA).
The device has two analog current inputs.

Use as an IO-Link device:

The device has an IO-Link communication interface that requires an IO-Link-capable module (IO-Link master) for interoperation. The IO-Link interface allows direct access to the process and diagnostic data and enables setting of the device parameters during operation.

Description	Item No.	PU	Technical Data
2AO FLD IOL CONV 4-20mA	765-2703/200-000	1	Supply voltage 24 VDC; -25 ... +25 %; (18 ... 30 VDC) Current consumption 300 mA Operation modes IO-Link
Accessories			Outputs
Mounting clip	765-101/000-000	1	Number of analog outputs 2
IO Device Description (IODD)	Download: www.wago.com		Connection technology M12-A socket; 5-pole
Approvals/Tests			Signal type (current) 4 ... 20 mA
Conformity marking	CE		Load impedance ≤ 300 Ω
UL listed	Pending		Accuracy 0.25 % of output range end value
IO-Link			IO-Link
MTTF	352 years		Communication interface IO-Link Class A/B
Technical Data			Transmission type COM2 (38.4 kBaud)
Ambient temperature (operation)	-25 ... +70 °C		IO-Link revision 1.1
Surrounding air temperature (storage)	-25 ... +70 °C		Process data 2 x 16-bit OUT (analog)
Relative humidity (without condensation)	max. 90 % (31 °C); linearly decreasing to 50 % (40 °C)		Process cycle time (min.) 3.6 ms
Operating altitude	0 ... 4000 m		Parameters via IO-Link Application-specific identifier; plant identifier; location identifier
Protection type	IP67		
Pollution degree	2		
Weight	91.5 g		
Dimensions	63 x 30 x 24 mm		
Housing material	PA		
Indicators	Analog output: 2 x LED, yellow; Power: 1 x LED, green		
Length of connection cables	20 m		

WAGO GmbH & Co. KG
Subject to changes

10.05.22

Postfach 2880 - D-32385 Minden
Hansastr. 27 - D-32423 Minden

Phone: +49(0)571/887-0
Fax: +49(0)571/887-844169

Email: info@wago.com
www.wago.com

List of Figures

Figure 1	View	11
Figure 2	Indicators – LEDs.....	12
Figure 3	Connections	13
Figure 4	Dimensional Drawings	14
Figure 5	Circuit Diagram	15
Figure 6	Input and Output Process Data.....	22
Figure 7	Analog Value Representation	23
Figure 8	Connection Example with IO-Link Master.....	25
Figure 9	Mounting Clip (Secured with an M4 Screw or Cable Tie)	26
Figure 10	Mounting Clip with Product Attached	26

List of Tables

Table 1	Legend for Figure “View”	11
Table 2	Legend for Figure “Indicators – LEDs”	12
Table 3	Legend for Figure “Connections”	13
Table 4	IO-Link Side (M12 A Plug)	13
Table 5	Actuator Side (M12 A Socket).....	13
Table 6	Technical Data – Communication	16
Table 7	Default Command – General	17
Table 8	Default Command	17
Table 9	Variables – Device Access – General.....	18
Table 10	Variables – Device Access	18
Table 11	Variables – Manufacturer Name – General	18
Table 12	Variables – Manufacturer Name	18
Table 13	Variables – Manufacturer Text – General	18
Table 14	Variables – Manufacturer Text.....	19
Table 15	Variables – Product Name – General	19
Table 16	Variables – Product Name	19
Table 17	Variables – Product ID – General	19
Table 18	Variables – Product ID	19
Table 19	Variables – Product Text – General.....	19
Table 20	Variables – Product Text.....	19
Table 21	Variables – Serial Number – General	19
Table 22	Variables – Serial Number	20
Table 23	Variables – Hardware Version – General	20
Table 24	Variables – Hardware Version	20
Table 25	Variables – Firmware Version – General	20
Table 26	Variables – Firmware Version.....	20
Table 27	Variables – Application-Specific Attribute – General	20
Table 28	Variables – Application-Specific Attribute	21
Table 29	Variables – System Tag – General	21
Table 30	Variables – System Tag.....	21
Table 31	Variables – Location Tag – General	21
Table 32	Variables – Location Tag	21
Table 33	Input Process Data	22
Table 34	Output Process Data.....	22
Table 35	Protecting Circuits against Overcurrent	24
Table 36	Legend for Figure “Connection Example with IO-Link Master”	25

Table 37	Diagnostics via Indicators	30
Table 38	Variables – Diagnostics – General.....	30
Table 39	Variables – Diagnostics	30
Table 40	Variables – Detailed Diagnostics – General	30
Table 41	Variables – Detailed Diagnostics	31
Table 42	Variables – Active Events – General	31
Table 43	Variables – Active Events	31
Table 44	Variables – Parameter Setting Errors – General	31
Table 45	Variables – Parameter Setting Errors	32
Table 46	Process Image – Error Types	32
Table 47	Process Image – Events	32
Table 48	Accessories.....	35

WAGO GmbH & Co. KG

Postfach 2880 · D - 32385 Minden
Hansastraße 27 · D - 32423 Minden

✉ info@wago.com
🌐 www.wago.com

Headquarters	+49 571/887 – 0
Sales	+49 (0) 571/887 – 44 222
Order Service	+49 (0) 571/887 – 44 333
Fax	+49 571/887 – 844169