

Block diagram of an input

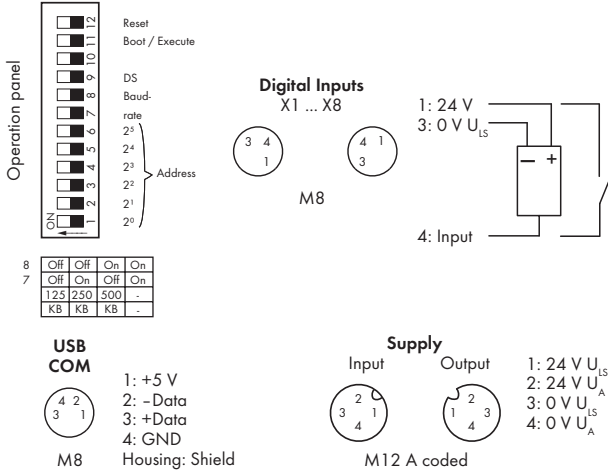
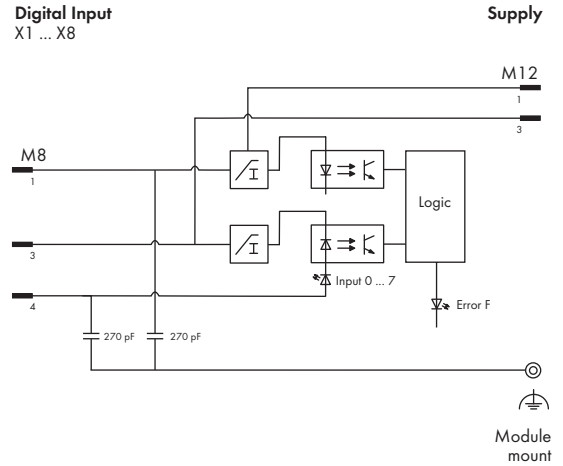

Technical Data

Digital inputs:

Number of inputs	8
Connection type (2)	M8 connectors, 3 poles
Wire connection	2- or 3-wire
Input filter	parametrizable
Input characteristic	Type 1, acc. to IEC 61131-2
Signal voltage (0)	-3 V ... +5 V DC
Signal voltage (1)	+15 V ... +30 V DC
Input wiring	high-side switching
Input voltage	24 V DC (-30 V DC < U _{IN} < +30 V DC)
Input current (typ.)	2.8 mA
Cable length, unshielded	≤ 30 m
Wrong connection of inputs	No effect

System bus:

Number of expendable modules	64
Connection type (3)	M12 connectors, B coded, 5 poles, shielded

Isolation:

Channel - Channel	No
U _{IS} , U _A , system bus, fieldbus	500 V DC each

Service:

Type	USB standard 1.1
Connection type (5)	M8 connectors, 4 poles

Standards and approvals:

DeviceNet	IEC62026-3, EN50325-2
Conformity marking	CE
Korea Certification	
UL 508	
BVS 15 ATEX E 098 X	II 3G Ex nA IIC T5 Gc, II 3D Ex tc IIIB T90°C Dc
IECEX BVS 15.0083X	Ex nA IIC T5 Gc, Ex tc IIIB T90°C Dc

Configurable functions:

Fieldbus coupler	see manual
Digital Inputs	
Input filter (per channel)	0.1/ 0.5/ 3 /15 /20 ms/ filter off
Inversion (per channel)	On/off
Online simulation (per channel)	Lock/unlock, simulation value: 0/1
Online simulation (per module)	Diagnostics

I/O diagnostics:

I/O diagnostics (per module)	Short circuit/overload of sensor supply Undervoltage (U _{IS} + U _A)
------------------------------	---

Technical Data

Process image:

Input process image	2048 bytes
Output process image	2048 bytes

LED indicators:

MS: DeviceNet module status	LED (green/red)
IO: IO status	LED (green/red)
NS: DeviceNet network status	LED (green/red)
MBO: MAC-ID/Baud rate overwritten	LED (orange)
CS: Fieldbus coupler status	LED (green/red)
SBM: System bus master status	LED (green/red)
F: Error status	LED (red)
0 ... 7: Input signal status	LED (yellow)
U _{IS} + U _A : Supply status	LED (green)
Indicators	Non-latching

General Specifications

Dimensions (mm) W x H x L	75 x 35.7 x 117
Weight	388 g