

# MOVILINK® Interface (RS-232, RS-485)

2 interfaces (2 x M12) + 4 digital inputs/outputs (2 x M12, two inputs/outputs per connector)

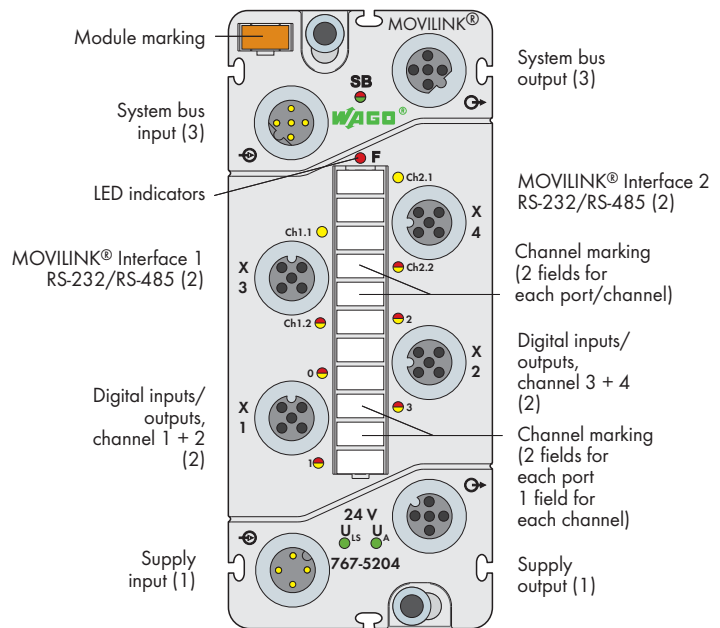

### Short description:

Interface module for drive control via MOVILINK® protocol (see note). The maximum number of drives per interface depends on the type of application and is described in more detail in the manual.

### Features:

- 2 MOVILINK® interfaces (RS-232, RS-485)
- 4 digital inputs/outputs, 24 VDC / 0.5 A
- Diagnostic-capable (channel by channel/module by module)
- Parametrizable (operating mode, baud rate, filter, inversion, substitute value strategy, substitute value, manual mode, online simulation and diagnostics)

### Included:

- 1 x WMB marker, orange
- 1 x marking strip
- 2 x M12 protective cap

### Note

MOVILINK® is a registered trademark of SEW-EURODRIVE GmbH & Co. KG

Description	Item No.	Pack. Unit
MOVILINK® Interface (RS-232, RS-485)	767-5204	1
<b>Product discontinuation</b>	<b>Last Call: 30.09.2018</b>	
Accessories	Item No.	
Marking strips, marking pen, spacer module and protective caps	see pages 520 ... 521	
IP67 cables and connectors	see pages 502 ... 517 + Section 11	
RS-422/-485 Termination M12	756-9218/050-000	
Technical Data		
<b>Module supply:</b>		
Connection type (1)	M12 connectors, A coded, 4 poles; Derating must be observed	
Current carrying capacity of supply connections	max. 8 A ( $U_{IS}$ : 4 A, $U_A$ : 4 A)	
Supply voltage		
Logic and sensor voltage $U_{IS}$	24 V DC (-25 % ... +30 %)	
Actuator voltage $U_A$	24 V DC (-25 % ... +30 %)	
Supply current		
Logic and sensor current $I_{IS}$	typ. 75mA	
Actuator current $I_A$	typ. 25 mA + Sensors (max. 400 mA) + Actuators 2.4 A (4 x 600 mA)	
Protection	Reverse voltage protection for $U_{IS}$ + $U_A$ Short-circuit protection for sensor/actuator supply	
<b>MOVILINK® Interface</b>		
Interfaces	2	
Connection type (2)	M12 connectors, A coded, 5 poles, shielded	
Transmission channels	1 Rx/D / 1 Tx/D (half duplex)	
Cable length	max. 15 m (RS-232); max. 200 m (RS-485)	

Technical Data	
<b>MOVILINK® Interface</b>	
Baud rate	9,600 Baud; 57,600 Baud
Protocols	MOVILINK® PDU types, 0x05 (cyclic) and 0x85 (acyclic)
Data bits (per channel)	8
Parity	Even
Stop bits	1
<b>Digital inputs:</b>	
Number of inputs	4
Connection type (2)	M12 connectors, A coded, 5 poles, shielded
Wire connection	2- or 3-wire
Input filter	Hardware: $\leq 110 \mu s$ Software: parametrizable
Input characteristic	Type 2, acc. to IEC 61131-2
Signal voltage (0)	-3 ... +5 VDC
Signal voltage (1)	+ 11 VDC ... $U_A$
Input wiring	High-side switching
Input voltage	24 VDC (-3 VDC < $U_{IN}$ < +30 VDC); Power from $U_A$ is strongly recommended, recovery for voltages > $U_A$
Input current (typ.)	7.3 mA
Connection of 2-wire BEROs	max. 1.5 mA admissible closed current
Cable length, unshielded	$\leq 30$ m
Wrong connection of inputs	No effect
<b>Input characteristic:</b>	
Input voltage	Typical input current
-3 V < $U_{IN}$ < 0 V	0 mA
5 V	2.3 mA ... 2.5 mA
11 V	6.4 mA ... 6.7 mA
24 V < $U_A$ < 31.2 V	7.3 mA ... 7.5 mA

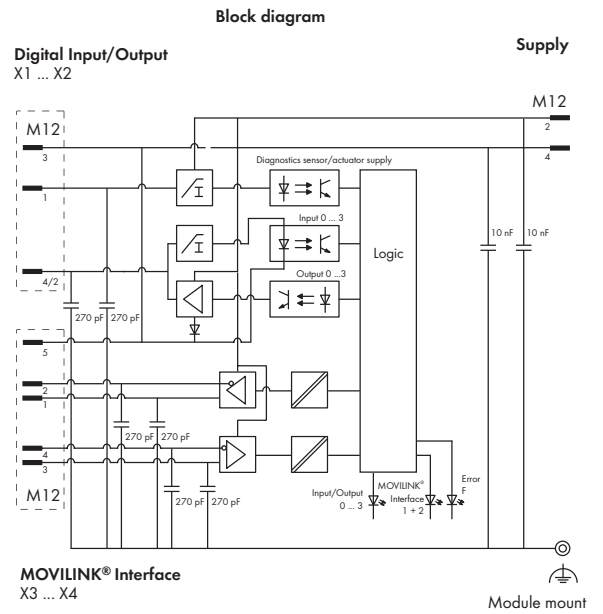
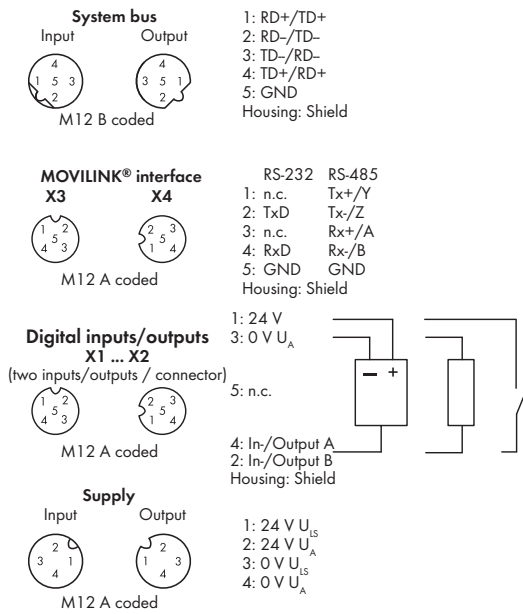

Technical Data	
<b>Digital outputs:</b>	
No. of outputs	4
Connection type (2)	M12 connectors, A coded, 5 poles, shielded
Wire connection	2- or 3-wire
Output voltage	≤ U <sub>A</sub>
Output current (per channel)	0.5 A (max. 0.6 A), short-circuit/overload proof (thermal disconnection)
Voltage drop against U <sub>A</sub> at 500 mA	max. 0.2 V DC
Output current (module)	max. 2 A
Leakage current in OFF state	typ. 5 µA
Output circuit	High-side switching
<b>Information on actuator selection:</b>	
Delay time hardware from "0" to "1" (0 - 90%)	typ. 90 µs (resistive load)
Delay time hardware from "1" to "0"	
Rise time from "0" to "1"	typ. 310 µs (resistive load)
Fall time from "1" to "0"	typ. 45 µs (resistive load)
Cable length	≤ 30 m
Reverse current (in case of recovery for voltages > U <sub>A</sub> )	≤ 1 A (error: 1 channel)
Type of load	Inductive, resistive loads and lamps
Switching frequency	Inductive load approx. 20 Hz Resistive load approx. 500 Hz Lamp load approx. 500 Hz
Parallel connection of 2 outputs	for power boost for redundant actuation of a load
Type of protective circuit	External protection (e.g., recovery diodes)
Output resistance	< 0,4 Ω
<b>Operating state influence on output:</b>	
PLC CPU stop	Acc. to substitute value strategy
Fieldbus disruption	Acc. to substitute value strategy
S-bus (system bus) disruption	0 V status
Supply voltage under rated voltage tolerance	0 V status
Interruption of supply voltage	0 V status
Output operation	Non-latching
Overload behavior	Automatic restart

Technical Data	
<b>System bus:</b>	
Connection type (3)	M12 connectors, B coded, 5 poles, shielded
<b>Standards and approvals:</b>	
Conformity marking	CE
UL 508	
BVS 15 ATEX E 098 X	II 3G Ex nA IIC T5 Gc, II 3D Ex tc IIIB T90°C Dc
IECEx BVS 15.0083X	Ex nA IIC T5 Gc, Ex tc IIIB T90°C Dc
<b>Isolation:</b>	
Channel - Channel	no
U <sub>IS</sub> , U <sub>A</sub> , system bus	500 V DC each
<b>Parameterizable functions, MOVILINK® interface</b>	
Operating mode (per module)	Easy Modus; Mailbox Modus
Type (per channel)	RS-232; RS-485
Baud rate (per channel)	9,600; 57,600 baud
<b>Parameterizable functions, digital inputs/outputs</b>	
Operating mode, input filter, inversion, substitute value strategy, manual mode, online simulation and diagnostics	For details, see manual.
<b>I/O diagnostics:</b>	
I/O diagnostics (per channel)	Overtemperature (DO)
I/O diagnostics (per module)	Sensor/Actuator supply short-circuit/overload Undervoltage (U <sub>IS</sub> + U <sub>A</sub> )
<b>Process image:</b>	
Process data width	Interface: 10-byte In/Out data; DIO: 1-byte In/Out data + 1-byte status
<b>LED indicators:</b>	
SB: System bus status	LED (green/red/orange)
F: Error status	LED (red)
0 - 3: Signal status, inputs/outputs	LED (yellow/red)
Ch1.1 + Ch2.1: Transmission status	LED (yellow)
Ch1.2 + Ch2.2: Reception status	LED (yellow/red)
U <sub>IS</sub> + U <sub>A</sub> : Supply status	LED (green)
Indicators	Non-latching
<b>General Specifications</b>	
Dimensions (mm) W x H x L	35.7 x 50 x 117
Weight	260 g