

SPEEDWAY I/O-System

General Product Information

For Cabinet-Free Data Acquisition

Where discrete wiring was previously required, fieldbuses now communicate between controller, system and machine.

Depending on the application, cabinet-free automation systems help minimize costs for planning, start-up and maintenance.

In addition to requiring a high degree of protection, a robust design and standardized connection technology, there is an increasing demand for advanced IP67 features that were once reserved only for IP20 systems, including:

- Real-time capable (isochronous data acquisition/output)
- Parameterizable
- Diagnostic capable
- Upgradable

Connect the switch cabinet directly to the field level without sacrificing functionality — SPEEDWAY perfectly tailors machines to meet specific, decentralized needs. Configuration is both easy and flexible, with changes made safely and quickly (plug & play).

Uncompromising Protection, Even in the Harshest Environments

Every module utilizes IP67-grade protection and robust construction. These fully encapsulated modules safeguard system operation, even when subjected to temperature extremes and prolonged periods of vibration. When combined, these robust design elements ensure long-term electronic circuit protection. Additionally, moisture cannot penetrate the units to cause damage (e.g., hairline cracks).

Segmented electromagnetic shielding consisting of a metalized housing and shield plating guarantees optimal electromagnetic compatibility within the housing. Potential interferences are directly discharged via the modules' attachments to the machine or system. Even in sub-zero temperatures, the WAGO SPEEDWAY I/O SYSTEM performs reliably.

Modular Design

WAGO 767 SPEEDWAY is a fieldbus-independent modular IP67 I/O system. It is linked via a fieldbus coupler with a higher-level controller. The fieldbus coupler already has digital inputs. An integrated system bus interface connects to other I/O modules. Fieldbus couplers and I/O modules can be extensively parameterized, allowing direct field-side acquisition and transmission of signals depending on the application needs.

Up to:

- 64 I/O modules per station
- 8 channels per module
- 520 channels per station
- 50 m between two modules
- 500 m total extension per station

Ergonomic Design

Standardized M8, M12 and M23 connections (metal design) ensure easy and safe wiring. The fieldbus, system bus, power supply and sensors/actuators are connected via several coded connectors. This streamlined approach prevents wiring errors.

To accommodate custom marking, the modules have marking strips and a WMB plate. Both the LEDs and marking field are uniquely assigned to the connection.

Flexible Assembly

The modules can be directly mounted on machines. Extensive engineering ensures compliance with standardized specifications from CNOMO guidelines regarding the spacing of assembly drill holes that are often used in passive distributor or sensor/actuator boxes. Adapters for both rail- and machine-mount brackets are also available.

Exceptional Degrees of Freedom

Featuring update capability, the SPEEDWAY I/O-System makes it easy to update fieldbus couplers and I/O module firmware to incorporate new functions. Integrated system parameter handling stores and loads parameter settings and checks that the replacement module is correct when installed. With option handling, variable I/O station configurations, which can occur when tools are changed in a machining center, can be implemented without engineering via PROFIBUS.

Advantages:

- Fully encapsulated for harsh environmental conditions
- Fieldbus-independent — Support all standard fieldbus protocols & ETHERNET standards
- Real-time capability up to isochronous mode for selected ETHERNET-based fieldbuses
- Exclusive use of standard pluggable connectors
- Flexible mounting options

SPEEDWAY I/O-System

Item Number Key

Explanation of the components of an item number key

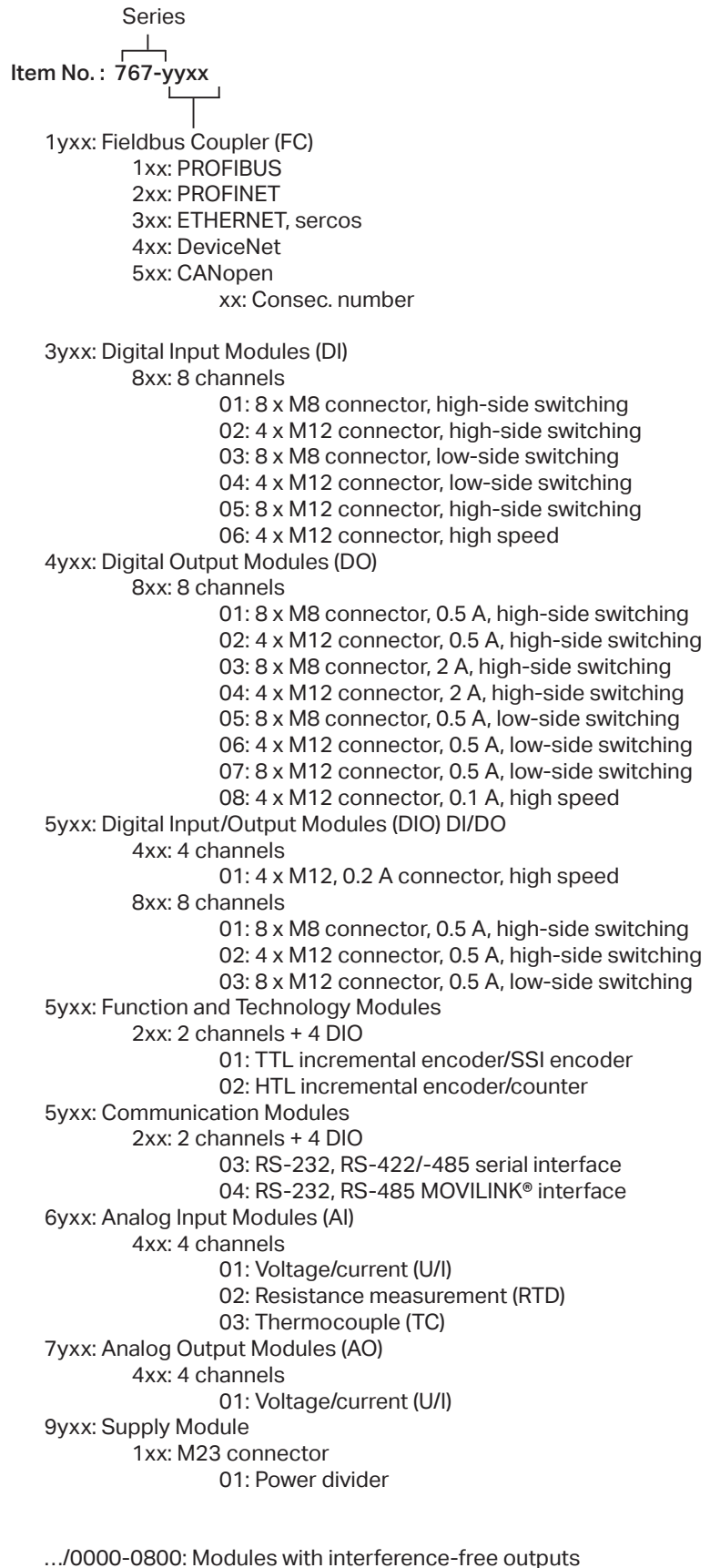

SPEEDWAY I/O-System Interfaces and Types

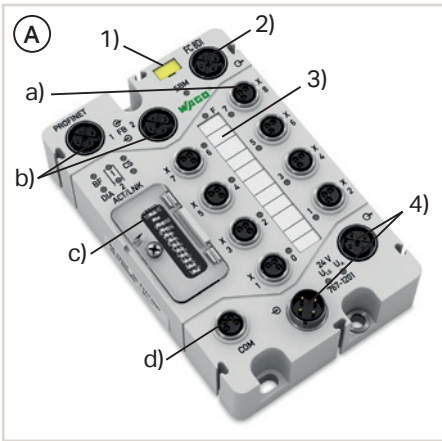

- (1) WMB module marking
- (2) M12 system bus connection
- (3) Sensor/actuator marking
- (4) M12 supply connections

Housing Design Fieldbus Coupler (A)

- M8 sensor/actuator connections (a)
- M12 fieldbus connections (b)
- Control panel (c)
- Service connection M8 (d)
- W x H x D (mm) 75 x 35.7 x 117

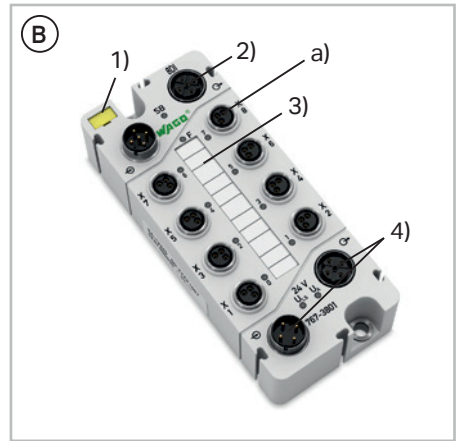

Housing Design 8 x M8 I/O Module (B)

- M8 sensor/actuator connections (a)
- W x H x D (mm) 50 x 35.7 x 117

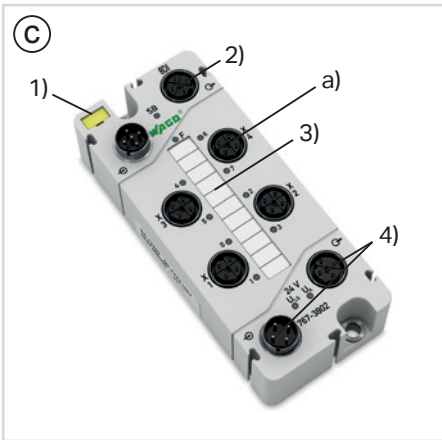

Housing Design 4 x M12 I/O Module (C)

- Sensor/actuator connections M12 (a)
- W x H x D (mm) 50 x 35.7 x 117

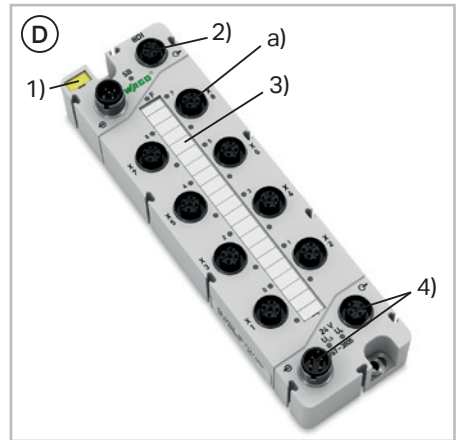

Housing Design 8 x M12 I/O Module (D)

- Sensor/actuator connections M12 (a)
- W x H x D (mm) 50 x 35.7 x 170

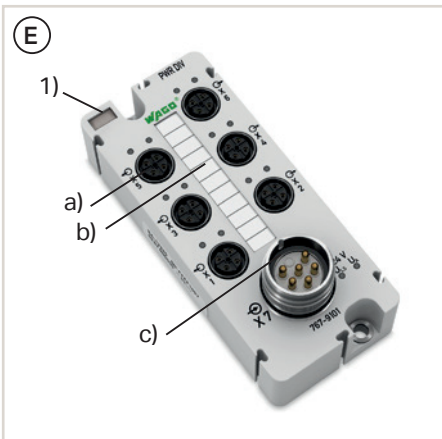

Power Divider Housing Design (E)

- Supply outputs M12 (a)
- Supply output marking (b)
- Supply input M23 (c)
- W x H x D (mm) 50 x 35.7 x 117

Spacer Module (F)

- Cable tie mounts (a)
- W x H x D (mm) 20 x 25 x 117

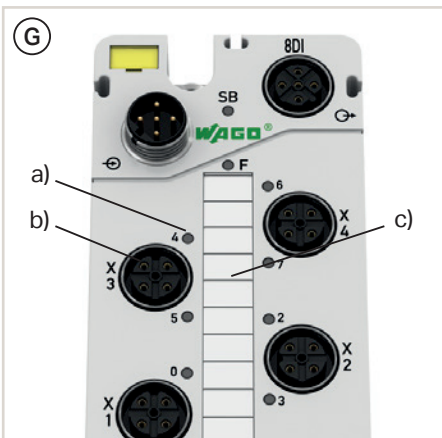
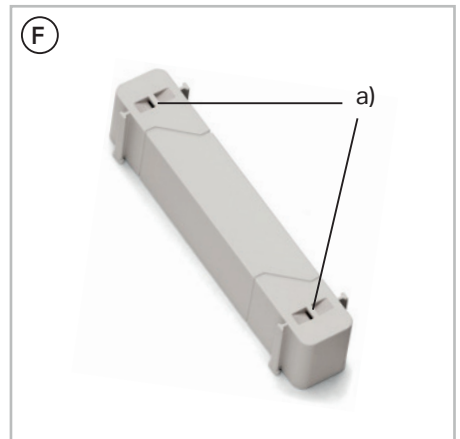

Signaling (G)

- Per channel 1–2 LEDs (a)
- Unique assignment to the connector (b)
- Unique assignment to the marking (c)

Degree of Protection (H)

- All modules are fully encapsulated
- Degree of protection: IP67
- Printing on back of module details pin assignment



SPEEDWAY I/O-System

Interfaces and Types

Fieldbus couplers

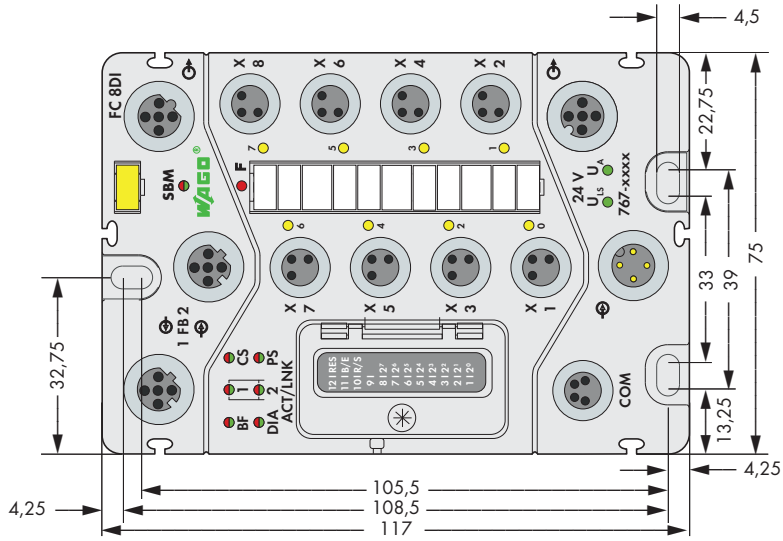

I/O module

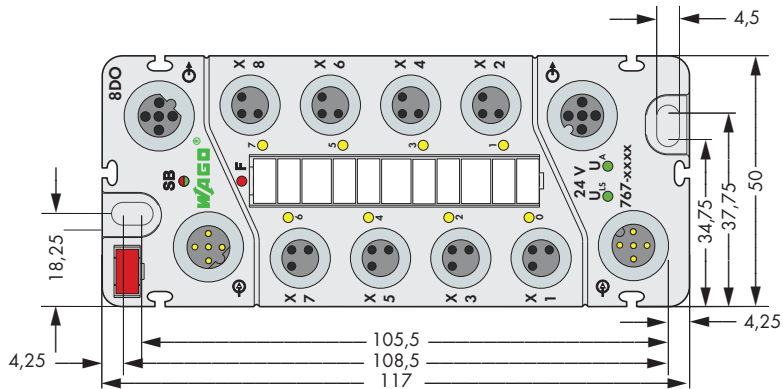

I/O module

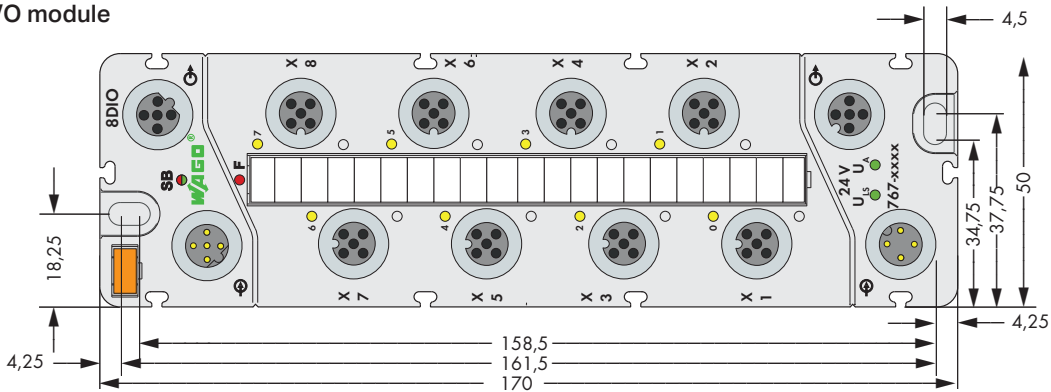

Power divider

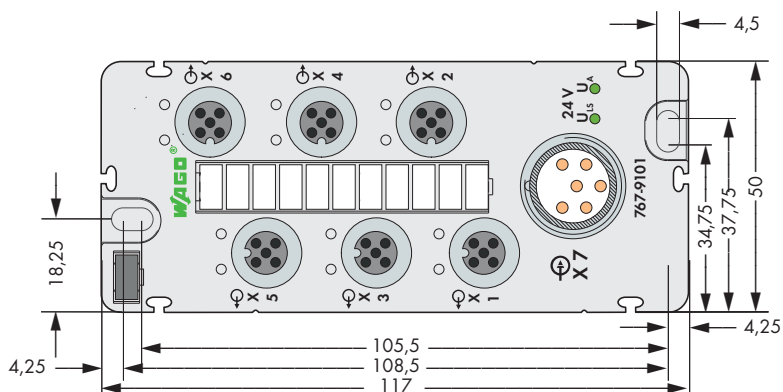

SPEEDWAY I/O-System

Application and Installation Instructions

Supply Modules

The WAGO SPEEDWAY system's modular structure allows both individual I/O modules and groups of modules to be supplied (e.g., emergency stop groups). Thus, different power supplies can be used at the same potential to operate each individual module and group of modules. Two supply lines are routed within the supply cables (gray). The logic and sensor supply (ULS) is always electrically isolated from the actuator supply (UA).

Additional I/O modules can be connected until the highest permissible current load of 4 A for one supply line (ULS and/or UA) is reached. The power supply must be re-established to connect additional SPEEDWAY modules. However, using 2 A output modules, power supply will not be transmitted in the event of an increased power demand.

WAGO's SPEEDWAY Power Divider permits ULS and UA power supply distribution via six M12 connectors. The combination of point-to-point and linear power distribution/distribution routing offers the greatest flexibility to optimize the supply lines for the respective application and to supply power over large distances.

Interference-Free in Safety-Related Applications

To easily and safely perform cost-effective, centralized deactivation of complete actuator groups safely, the actuator's power supply can be switched off using a safety switching device. This can either be performed for each individual actuator or by turning off the power supply to a group of control outputs.

In the event of failure, ensure that no interference from other current or power circuits occurs — even when the control voltage is switched off — so the defined safety function properties (logic and time response) remain unchanged.

Some modules are designed to provide interference-free safety functionality. These modules comply with safety requirements up to Category 4 of DIN EN ISO 13849-1:2007. Safety category and performance level depend solely on the safety components and their wiring.

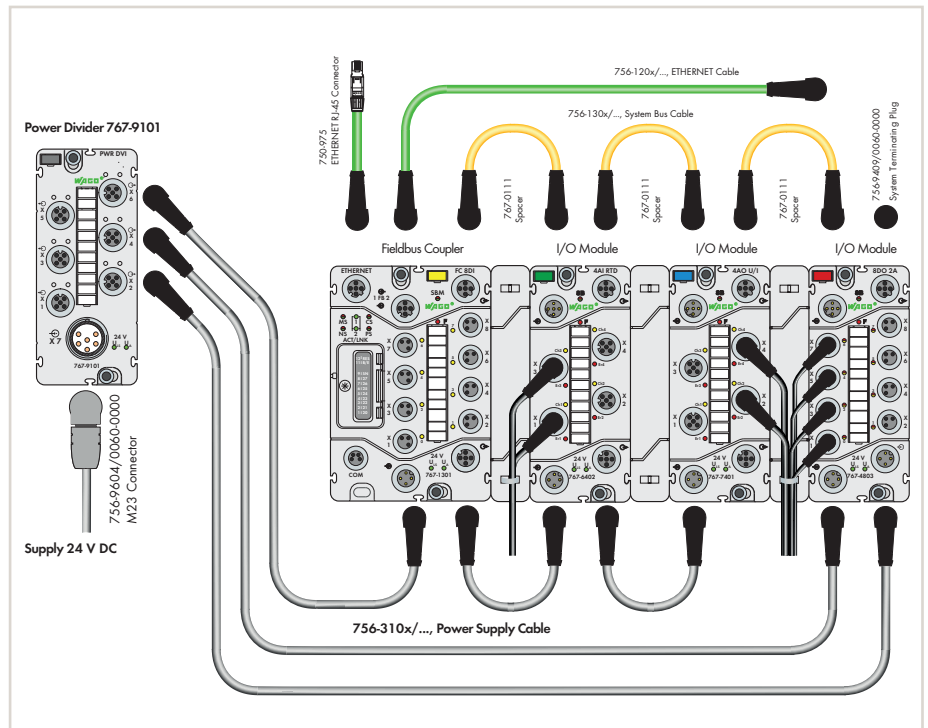

Notice:

Interference-free WAGO I/O modules are not a component of the safety function and do not replace the safety switching device! When using the components in safety functions, the corresponding notes must be observed in the relevant manual.

Notice:

For interference-free operation, it is necessary to lay the power cables separately or to use shielded supplied lines. Please observe the notes in the manual!

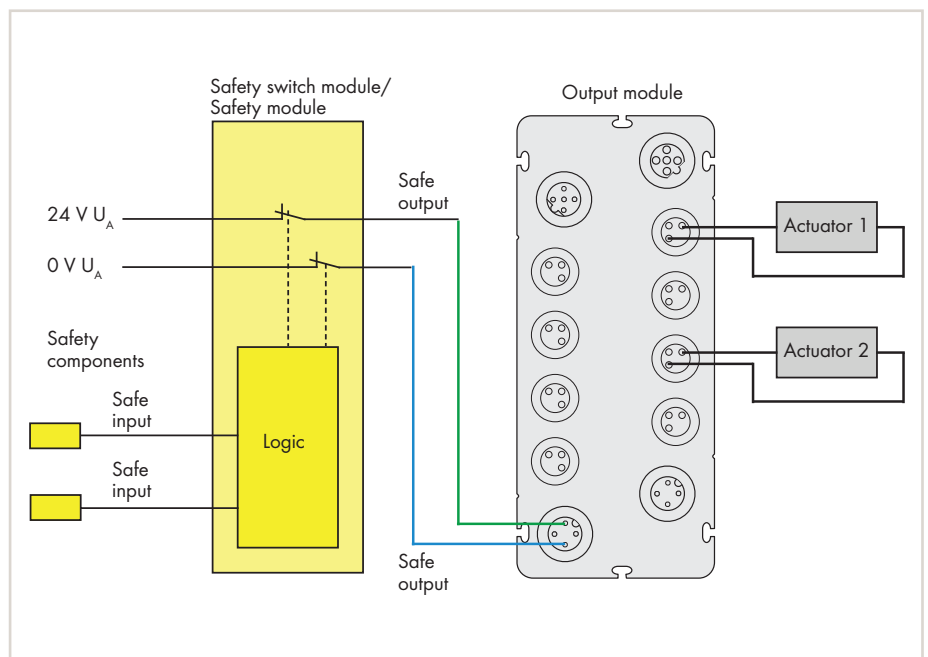

Example: Two-pin shutdown of the power supply of all digital outputs

SPEEDWAY I/O-System

Standards and Rated Conditions

General Specifications	
System supply voltage	24 VDC (-25 ... +30 %)
Ambient temperature (operation)	-25 °C ... +60 °C; temperature change 3 K/s
Ambient temperature (storage)	-40 ... +85 °C
Relative humidity	5 ... 95 %, without condensation
Operating altitude	-1000 ... 2000 m; air pressure 1080 ... 795 hPa
Altitude at storage/transport	-1000 ... 3500 m; air pressure 1080 ... 660 hPa
Free fall	≤ 1 m per EN 61131-2
Pollution degree	3 per IEC 60664 (IEC 61131)
Protection class	III per IEC 60536 (VDE 0106, Part 1)
Vibration resistance	5 g acc. IEC 60068-2-6
Shock resistance	Short-term: 50 g/11 ms/half-sine acc. IEC 60068-2-27 Long-term: 30 g/6 ms/half-sine acc. IEC 60068-2-29
EMC immunity to interference	EN 61000-6-2
EMC emission of interference	EN 61000-6-4
Protection type	IP67 (NEMA 6&6P) per DIN 40050 (EN 60529)
Mounting position	Any
Housing material	Polyamide (PA), light gray (RAL7035); Makrolon (address switch cover), transparent; Flammability per UL94-V0; halogen, silicon-free Potting: Polyurethane (PUR), halogen/silicon-free
UV resistance	1,000 h UV continuous light per DIN EN ISO 4892-2B
Maximum contaminant concentration	SO ₂ < 0.5 ppm; H ₂ S < 0.1 ppm
Current carrying capacity (supply connections)	Max. 8 A (ULS: 4 A; UA: 4 A)
Isolation	500 V system/supply

SPEEDWAY I/O-System

Approvals

Overview of the approvals in the article comparison in Section 12, Technical Appendix, or online under www.wago.com

