

# WAGO-SPEEDWAY 767

## Manual

---



---

**767-5203**  
**Serial Interface (RS-232, RS-422/-485)**  
**2 interfaces (2xM12) + 4 digital inputs/outputs**  
**(2xM12, two inputs/outputs per connector)**

Version 1.1.0

© 2016 by WAGO Kontakttechnik GmbH & Co. KG  
All rights reserved.

### **WAGO Kontakttechnik GmbH & Co. KG**

Hansastraße 27  
D-32423 Minden

Phone: +49 (0) 571/8 87 – 0  
Fax: +49 (0) 571/8 87 – 1 69

E-Mail: [info@wago.com](mailto:info@wago.com)

Web: <http://www.wago.com>

### **Technical Support**

Phone: +49 (0) 571/8 87 – 5 55  
Fax: +49 (0) 571/8 87 – 85 55

E-Mail: [support@wago.com](mailto:support@wago.com)

Every conceivable measure has been taken to ensure the accuracy and completeness of this documentation. However, as errors can never be fully excluded, we always appreciate any information or suggestions for improving the documentation.

E-Mail: [documentation@wago.com](mailto:documentation@wago.com)

We wish to point out that the software and hardware terms as well as the trademarks of companies used and/or mentioned in the present manual are generally protected by trademark or patent.

## Table of Contents

<b>1</b>	<b>Notes about this Documentation.....</b>	<b>6</b>
1.1	Validity of these Operating Instructions .....	6
1.2	Copyright.....	6
1.3	Symbols.....	7
1.4	Number Notation.....	9
1.5	Font Conventions .....	9
<b>2</b>	<b>Important Notes .....</b>	<b>10</b>
2.1	Legal Bases .....	10
2.1.1	Subject to Changes .....	10
2.1.2	Personnel Qualification .....	10
2.1.3	Intended Use.....	11
2.1.4	Technical Condition of Specified Devices.....	11
2.2	Safety Advice (Precautions).....	12
2.3	Safety Equipment.....	13
2.4	Notes on Operation .....	14
<b>3</b>	<b>Device Description .....</b>	<b>15</b>
3.1	Connectors.....	17
3.2	Marking Possibilities and Fastening .....	18
3.3	Display Elements .....	19
3.4	Labeling.....	20
3.5	Schematic Diagram .....	22
3.6	Dimensions.....	23
3.7	Technical Data .....	24
3.7.1	Device Data .....	24
3.7.2	Supply.....	24
3.7.3	Communication .....	24
3.7.4	Serial Interfaces.....	25
3.7.5	Digital Inputs .....	25
3.7.6	Input Characteristic .....	25
3.7.7	Digital Outputs .....	26
3.7.8	Information for Actuator Selection .....	26
3.7.9	Effect of Operating States .....	27
3.7.10	Configurable Functions of the Serial Interfaces.....	27
3.7.11	Configurable Functions of the Digital Inputs/Outputs.....	27
3.7.12	Diagnostics .....	27
3.7.13	Process Image.....	28
3.7.14	Indicators .....	28
3.7.15	Isolation .....	28
3.8	Approvals .....	29
3.9	Standards and Guidelines.....	30
<b>4</b>	<b>Mounting.....</b>	<b>31</b>
4.1	Information on Mounting.....	31
4.2	Tools and Accessories Required for Mounting.....	33
4.3	Direct Mounting on Your System.....	34
4.4	Mounting on a Carrier Rail (only with WAGO Accessories).....	35

4.4.1	Fastening the Carrier Rail Adapter to the Module .....	35
4.4.2	Fastening the Module with Carrier Rail Adapter to a Carrier Rail ....	36
4.5	Mounting on a Profile Rail (only with WAGO Accessories) .....	37
4.5.1	Fastening the Profile Adapter to the Module .....	37
4.5.2	Fastening the Module with Profile Adapter to a Profile Rail .....	38
4.6	Marking and Replacing the Marking Spaces .....	39
4.7	Mounting the Spacer in the Case of Compact Arrangement.....	40
<b>5</b>	<b>Connecting Data and Supply Cables.....</b>	<b>42</b>
5.1	Notes .....	42
5.2	Required Accessories .....	43
5.3	Connecting the S-BUS Cables .....	44
5.4	Connecting the Supply Cable.....	46
5.5	Connecting Interface Cables .....	48
5.6	Connecting Sensor/Actuator Cables .....	50
<b>6</b>	<b>Commissioning .....</b>	<b>52</b>
<b>7</b>	<b>Parameterizing .....</b>	<b>53</b>
7.1	Electronic Type Label .....	55
7.2	Diagnostic Overview.....	56
7.3	Input and Output Parameters.....	58
7.3.1	Connection Mode "Digital Output" .....	59
7.3.2	Connection Mode "Digital Input" .....	61
7.4	Parameters of the Serial Interfaces.....	62
7.4.1	Input Buffer, Serial Interface.....	64
7.4.2	Output Buffer, Serial Interface .....	65
7.5	Global Settings .....	66
7.6	Parameters of Field Supply .....	66
7.7	Automatic Storage of System Parameters.....	67
7.8	Updating the Firmware .....	67
<b>8</b>	<b>Process Image .....</b>	<b>68</b>
8.1	Input Data.....	69
8.2	Output Data .....	70
<b>9</b>	<b>Serial Interface .....</b>	<b>72</b>
9.1	Function Block CODESYS V3 .....	72
9.2	Function Block Simatic S7.....	72
9.3	Programmatic Data Transfer .....	72
9.3.1	Example of Message Processing .....	73
9.3.2	Flow Control.....	74
9.3.3	Control of Internal Buffers .....	75
<b>10</b>	<b>Diagnostics .....</b>	<b>76</b>
10.1	LED Signaling.....	76
<b>11</b>	<b>Service .....</b>	<b>80</b>
11.1	Updating the Firmware .....	80
11.2	Replacing the Module .....	80
11.2.1	Disconnecting the Cables .....	80
11.2.2	Removing the Module from Your System .....	81
11.2.3	Removing the Module from the Carrier Rail .....	81

---

11.2.4	Removing the Module from the Profile Adapter.....	82
11.2.5	Connecting the Module .....	82
11.3	Disposal.....	82
<b>12</b>	<b>Appendix.....</b>	<b>83</b>
12.1	Diagnostic Information .....	83
12.2	Mailbox 2.0 Transmission Method .....	84
12.2.1	Message .....	84
12.2.2	Transmission Channel .....	85
12.2.2.1	The Handshake Byte.....	86
12.2.3	Communication Phases .....	87
12.2.3.1	Synchronization .....	87
12.2.3.1.1	Mailbox Commands.....	87
12.2.3.1.2	Acknowledgement .....	88
12.2.3.1.3	Signaling .....	88
12.2.3.1.4	Finite Automation .....	89
12.2.3.2	Data Exchange .....	90
12.2.3.2.1	Example .....	91
	<b>List of Figures .....</b>	<b>92</b>
	<b>List of Tables.....</b>	<b>93</b>

# 1 Notes about this Documentation

The module shall only be installed and operated in conjunction with these operating instructions and the system description.

---

## WARNING

### Observe release notes!

Please note that, within the SPEEDWAY system, a function is provided **without restriction** only if all system's components have the same system-wide firmware release. Therefore, always observe the appropriate release notes on products used.

---

---

## NOTICE

### Supply layout!

In addition to these operating instructions, you will need the “WAGO *SPEEDWAY 767*, System Description and Information” manual, which can be downloaded at [www.wago.com](http://www.wago.com). There you will find information regarding supply layout, etc.

---

---

## Note



### Always retain this documentation!

This documentation is part of the product. Therefore, retain the documentation during the entire service life of the product. Pass on the documentation to any subsequent user. In addition, ensure that any supplement to this documentation is included, if necessary.

---

## 1.1 Validity of these Operating Instructions

These operating instructions are only applicable to the WAGO *SPEEDWAY 767* Series module Serial Interface (RS-232, RS-422/-485), 767-5203.

## 1.2 Copyright

This Manual, including all figures and illustrations, is copyright-protected. Any further use of this Manual by third parties that violate pertinent copyright provisions is prohibited. Reproduction, translation, electronic and phototechnical filing/archiving (e.g., photocopying) as well as any amendments require the written consent of WAGO Kontakttechnik GmbH & Co. KG, Minden, Germany. Non-observance will involve the right to assert damage claims.

## 1.3 Symbols

---

 **DANGER**

**Personal Injury!**

Indicates a high-risk, imminently hazardous situation which, if not avoided, will result in death or serious injury.

---

---

 **DANGER**

**Personal Injury Caused by Electric Current!**

Indicates a high-risk, imminently hazardous situation which, if not avoided, will result in death or serious injury.

---

---

 **WARNING**

**Personal Injury!**

Indicates a moderate-risk, potentially hazardous situation which, if not avoided, could result in death or serious injury.

---

---

 **CAUTION**

**Personal Injury!**

Indicates a low-risk, potentially hazardous situation which, if not avoided, may result in minor or moderate injury.

---

---

**NOTICE**

**Damage to Property!**

Indicates a potentially hazardous situation which, if not avoided, may result in damage to property.

---

---

**NOTICE**

**Damage to Property Caused by Electrostatic Discharge (ESD)!**

Indicates a potentially hazardous situation which, if not avoided, may result in damage to property.

---

---

**Note**

**Important Note!**

Indicates a potential malfunction which, if not avoided, however, will not result in damage to property.

---

## *Information*



**Additional Information:**

Refers to additional information which is not an integral part of this documentation (e.g., the Internet).

---

## 1.4 Number Notation

Table 1: Number Notation

Number Code	Example	Note
Decimal	100	Normal notation
Hexadecimal	0x64	C notation
Binary	'100' '0110.0100'	In quotation marks, nibble separated with dots (.)

## 1.5 Font Conventions

Table 2: Font Conventions

Font Type	Indicates
<i>italic</i>	Names of paths and data files are marked in italic-type. e.g.: <i>C:\Program Files\WAGO Software</i>
<b>Menu</b>	Menu items are marked in bold letters. e.g.: <b>Save</b>
>	A greater-than sign between two names means the selection of a menu item from a menu. e.g.: <b>File &gt; New</b>
<b>Input</b>	Designation of input or optional fields are marked in bold letters, e.g.: <b>Start of measurement range</b>
“Value”	Input or selective values are marked in inverted commas. e.g.: Enter the value “4 mA” under <b>Start of measurement range</b> .
<b>[Button]</b>	Pushbuttons in dialog boxes are marked with bold letters in square brackets. e.g.: <b>[Input]</b>
<b>[Key]</b>	Keys are marked with bold letters in square brackets. e.g.: <b>[F5]</b>

## **2 Important Notes**

This section includes an overall summary of the most important safety requirements and notes that are mentioned in each individual section. To protect your health and prevent damage to devices as well, it is imperative to read and carefully follow the safety guidelines.

### **2.1 Legal Bases**

#### **2.1.1 Subject to Changes**

WAGO Kontakttechnik GmbH & Co. KG reserves the right to provide for any alterations or modifications that serve to increase the efficiency of technical progress. WAGO Kontakttechnik GmbH & Co. KG owns all rights arising from the granting of patents or from the legal protection of utility patents. Third-party products are always mentioned without any reference to patent rights. Thus, the existence of such rights cannot be excluded.

#### **2.1.2 Personnel Qualification**

All sequences implemented on the module may only be carried out by electrical specialists with sufficient knowledge in automation. The specialists must be familiar with the current standards and guidelines for the module and automation environment.

### 2.1.3 Intended Use

The module 767-5203 has two serial interfaces and configurable digital inputs and outputs. These are suitable for the output of digital signals as well as for detecting digital field signals.

The module is supported by all 767 fieldbus couplers of Release 5 or higher.

The module may not be used to control safety-related functions, i.e. it cannot be a functional part of a safety function.

The module may only be operated in combination with components of the WAGO *SPEEDWAY* 767 Series.

The module was developed for applications requiring IP 67 (NEMA type 6, 6P) protection.

Applications other than those described in this manual are not permitted.

### 2.1.4 Technical Condition of Specified Devices

The devices to be supplied ex works are equipped with hardware and software configurations, which meet the individual application requirements. WAGO Kontakttechnik GmbH & Co. KG will be exempted from any liability in case of changes in hardware or software as well as to non-compliant usage of devices.

Please send your request for modified and new hardware or software configurations directly to WAGO Kontakttechnik GmbH & Co. KG.

## 2.2 Safety Advice (Precautions)

### DANGER



#### **Electric voltage!**

Operate the 767 Series components exclusively with 24 VDC PELV (Protective Extra Low Voltage) or SELV (Safety Extra Low Voltage) voltage sources. Failure to comply may result in electric shock.

### CAUTION



#### **Hot connection sockets!**

Even when taking into account derating, high surface temperatures on the metallic connection sockets and on the enclosure can arise during operation. If the 767 Series component has been in operation, allow it to cool off before moving it.

### NOTICE

#### **The highest current carrying capacity of the supply contacts is 4 A!**

Always observe the maximum current carrying capacity per supply line ( $U_{LS}$ ,  $U_A$ ) for each 767 Series component and the overall power consumption for all 767 components. Neither of these values shall exceed 4 A since an increase in current causes the contacts to overheat and damages the 767 Series components. Information regarding the power demand of each 767 Series component can be found in the corresponding data sheet, which is available from [www.wago.com](http://www.wago.com).

### NOTICE

#### **Exposed connections!**

If connections have not been closed with protective caps, liquid or dirt can penetrate the components of the 767 Series module and ruin it. Therefore, close all unnecessary connections with protective caps, which must be ordered separately, in order to maintain the IP67 degree of protection. (See section “Accessories” of the fieldbus coupler/controller manual.)

- Disconnect the power supply from the system on which you wish to mount the 767 Series device.
- Observe the appropriate accident prevention regulations for your system during assembly, start-up, maintenance, and repairs. For example, BGV A3, “Electrical systems and equipment”.
- The operating instructions for the 767 Series module and the system description must be laid out ready on site.
- Observe the exact positioning (coding) between plug and socket.
- The 767 Series device shall not come into contact with substances having seeping and insulating properties. Otherwise, additional measures shall be

taken for the device, such as installation of an enclosure that is resistant to the above-mentioned substance properties.

- Electronic components fulfilling the ESD requirements according to the IEC 61000-6-2 are integrated in the 767 device. As higher voltages may occur, under unfavorable circumstances, due to electrical charge in the field, discharge must be ensured before performing work on the 767 system.
- Ensure that the potential equalization is correctly laid out.
- Keep all cables a sufficient distance away from electromagnetic sources of interference in order to maintain a high level of interference resistance of the 767 system against electromagnetic emissions. Use only shielded cables at the necessary locations, and always observe the appropriate standards for EMC-suitable installations.
- For the power supply and for the S-BUS, use only pre-assembled WAGO system cables, so the specified characteristics of the technical data can be achieved.
- Replace defective or damaged modules (e.g., deformed connections), else function disruptions can occur in the respective fieldbus stations or nodes.
- When laying any cables, make sure that you do not lay them within the shear range of movable machine parts.
- For each activity, observe the corresponding personnel qualification in the corresponding section.
- Observe the marking on the front and rear side of the module.

## 2.3 Safety Equipment

All 767 Series products are designed to meet the requirements of IP67. This includes complete protection against accidental contact with electrical voltage and currents – even when wet.

## 2.4 Notes on Operation

When integrating the 767 module in your machine or system, all the currently applicable norms, regulations and guidelines shall be observed during all activities: for example, BGV A3, “Electrical systems and equipment”, DIN EN 418, EN 60204. The emergency stop equipment shall remain effective in all operating modes of the system and machine.

### **For protection from electromagnetic interferences**

- Connect your system to protective earth (PE), and
- Ensure that the cable routing and the installation of the fieldbus cable, S-BUS cable, supply cable, and sensor or actuator cable are correct.

### **The following elements for 24 V supply shall be present:**

- Outer lightning protection on buildings
- Inner lightning protection of supply lines and signal lines
- Safe electrical separation of low voltage 24 VDC through PELV (Protective Extra Low Voltage) or SELV (Safety Extra Low Voltage) voltage sources

### 3 Device Description

The module 767-5203 allows the user to connect devices with an RS-232, RS-422 or RS-485 interface. In addition, two signal channels each can be parameterized as digital outputs or outputs on two connections. In this way, up to four digital sensors or actuators can be connected to both control solenoid valves, contactors, etc. and to evaluate sensors, proximity switches, etc.

The properties (e.g. filter times) of all signal channels of the module can be parameterized independently: depending on fieldbus, via the device description file (e.g. GSD, GSDML, etc.) of a fieldbus or independent of the fieldbus, via an FDT/DTM frame application such as WAGOframe.

The module does not support any higher protocol levels. All data is transferred transparently to the connected fieldbus master. A CODESYS function block and a function block for Siemens S7 are available to make using the module easier.

With the 4096-byte reception buffer, the serial interface supports high transmission rates between module and connected device independent of the speed of the fieldbus. The 4096-byte output buffer provides fast transmission of larger data strings.

The module works independent of the fieldbus used in full-duplex or half-duplex mode at up to 115200 baud depending on the configuration.

The default operating mode is RS-485 half-duplex. The default data transmission rate is 9600 baud. 1 start bit, 8 data bits and 1 stop bit are send. There is no parity generation and dataflow control.

As required, the module can be reconfigured in wide ranges:

- Operating mode: RS-232 or RS-422/RS-485
- Baud rate: 300 - 115200
- Data bits: 7 or 8
- Stop bits: 1 or 2
- Parity: even / odd / none
- Flow control: RTS/CTS or XOn/XOff

In RS-232 mode, the interface works in accordance with the TIA/EIA-232-F and CCITT V.28/DIN 66259-1 standards. In RS-485/RS-422 mode, the interface works in accordance with the TIA/EIA-485-A, DIN 66259 standards. Bit transmission is in accordance with 8482/DIN 66259-4.

The positive switching digital inputs have a characteristic in accordance with IEC61131-2, Type 2. They have extensive parameterization options such as filter times or signal inversion.

The positive switching outputs are designed for 0.5 A (max. 0.6 A) and short circuit/overload protected. Extensive parameterization options are also available for the outputs as signal inversion, substitute value strategy or restart behavior.

### 3.1 Connectors

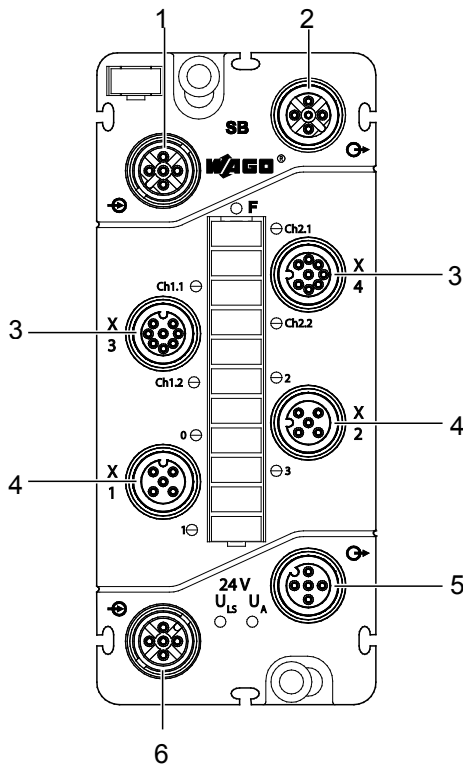

Figure 1: Connectors (exemplary)

Table 3: Legend for figure "Connectors"

Position	Description	Function
1	S-BUS input M12 plug, B-coded	For transmitting data from previous 767 Series components.
2	S-BUS output M12 socket, B-coded	For transmitting S-BUS data to the next 767 Series components or to the S-BUS terminator.
3	Serial interfaces 1 and 2 M12 socket, A coded	Devices with one of the following interfaces are supported: RS-232, RS-422, RS-485.
4	Digital inputs and outputs X1 and X2, (double assignment) M12 socket, A coded	For connecting digital sensors or actuators.
5	Supply output M12 socket, A coded	For providing system and/or actuator power supply to adjacent I/O modules.
6	Supply input M12 plug, A coded	For infeed of system and actuator supply.

## 3.2 Marking Possibilities and Fastening

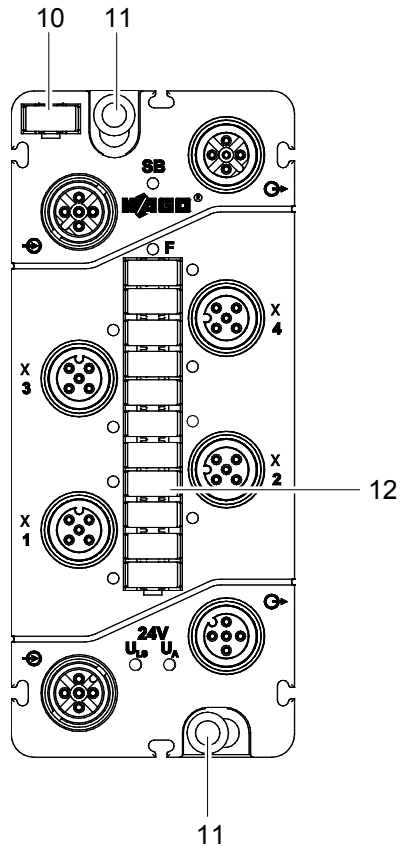

Figure 2: Marking possibilities and fastening (exemplary)

Table 4: Legend for figure "Marking possibilities and fastening"

Position	Description	Function
10	Module marker card	For identifying the module within a fieldbus node.
11	Mounting holes	With integrated function earth (FE) socket for fastening and grounding the module.
12	Marker strips	For identifying inputs.

### 3.3 Display Elements

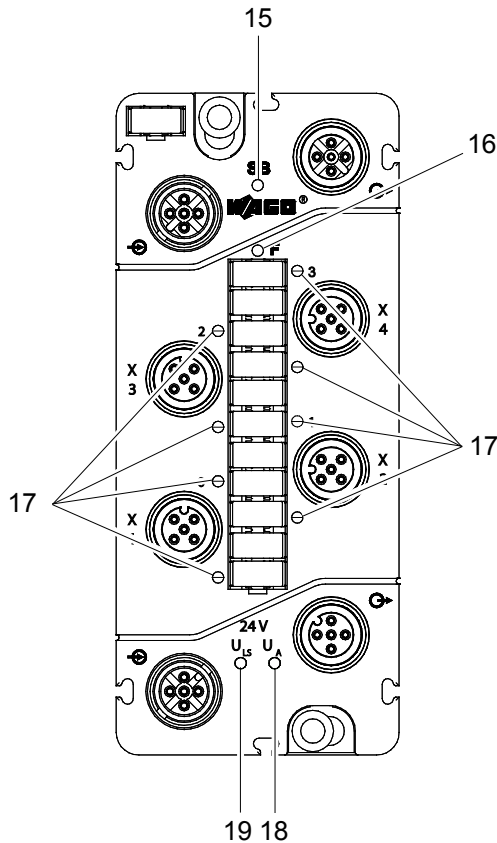

Figure 3: Display elements (exemplary)

Table 5: Legend for figure "Display elements"

Position	LED	Color	Meaning
15	SB	Green/red/orange	S-BUS status
16	F	Red	Diagnostic information
17	Ch1.1	Yellow	Status of the serial interfaces. Detailed information can be found in section "Diagnostics" > "LED Signaling".
	Ch1.2	Yellow, red	
	Ch2.1	Yellow	
	Ch2.2	Yellow, red	
	0 ... 3	Yellow, red	Information about the inputs and outputs. Detailed information can be found in section "Diagnostics" > "LED Signaling".
18	U <sub>A</sub>	Green	Actuator supply is present.
19	U <sub>LS</sub>	Green	Logic supply and sensor supply are present.

## Note



### Detailed information

Detailed information can be found in section "Diagnostics" > "LED Signaling".

## 3.4 Labeling

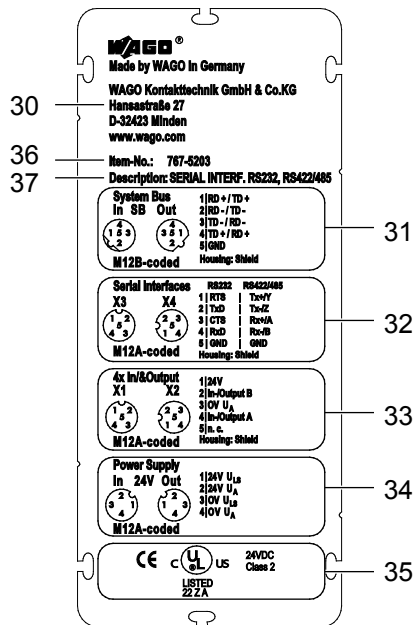

Figure 4: Labeling

Table 6: Legend for figure "Labeling"

Position	Description
30	Manufacturer's mailing address
31	Pin assignment of S-BUS
32	Pin assignment of the serial interfaces
33	Pin assignment of the inputs/outputs
34	Pin assignment of supply input and output
35	Information on approvals and CE marks
36	Item number
37	Clear labeling of the module

On the side of the module is a label, with information that would prove useful in the case of a complaint:

- BA: Work order number (40)
- SN: Serial number (40)
- Manufacturing number (41)

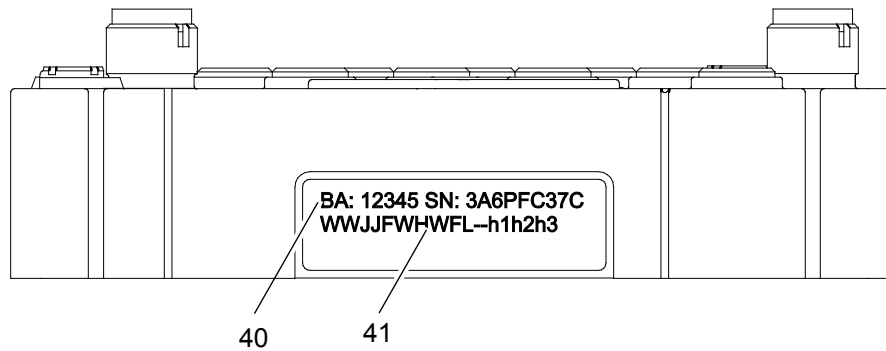

Figure 5: Label on the module

Table 7: Description of manufacturing number

Abbreviation	Description
WW	Week of production
JJ	Year of production
FW	Firmware release index When updating the firmware, please note that, the firmware release index may not be conformed to the printed firmware release index on the side of the fieldbus coupler. The “Electronic Type Label” (see section “Electronic Type Label”) shows the actual firmware release index.
HW	Hardware release index
FL	Firmware loader release index
h1h2h3	Internal manufacturer information

### 3.5 Schematic Diagram

The following schematic diagram provides an overview of the power supply and principle of operation of the power supply connections, as well as the digital inputs and outputs of the modules (see also sections "Connecting the Supply Cable" and "Connecting the Sensor/Actuator Cable").

Please note that the common power supply of the sensors and actuators is distributed to the module connections X1 and X2 (each pin 1).

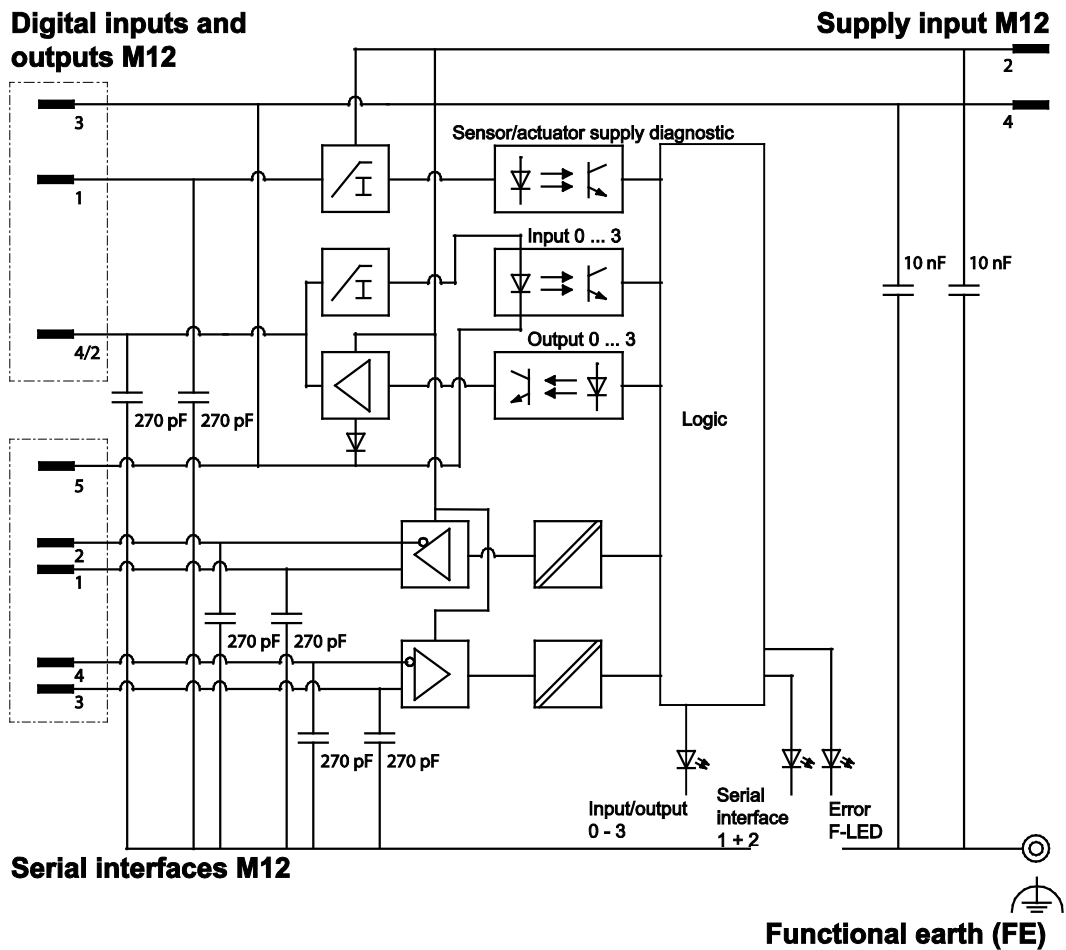

Figure 6: Schematic diagram

### 3.6 Dimensions

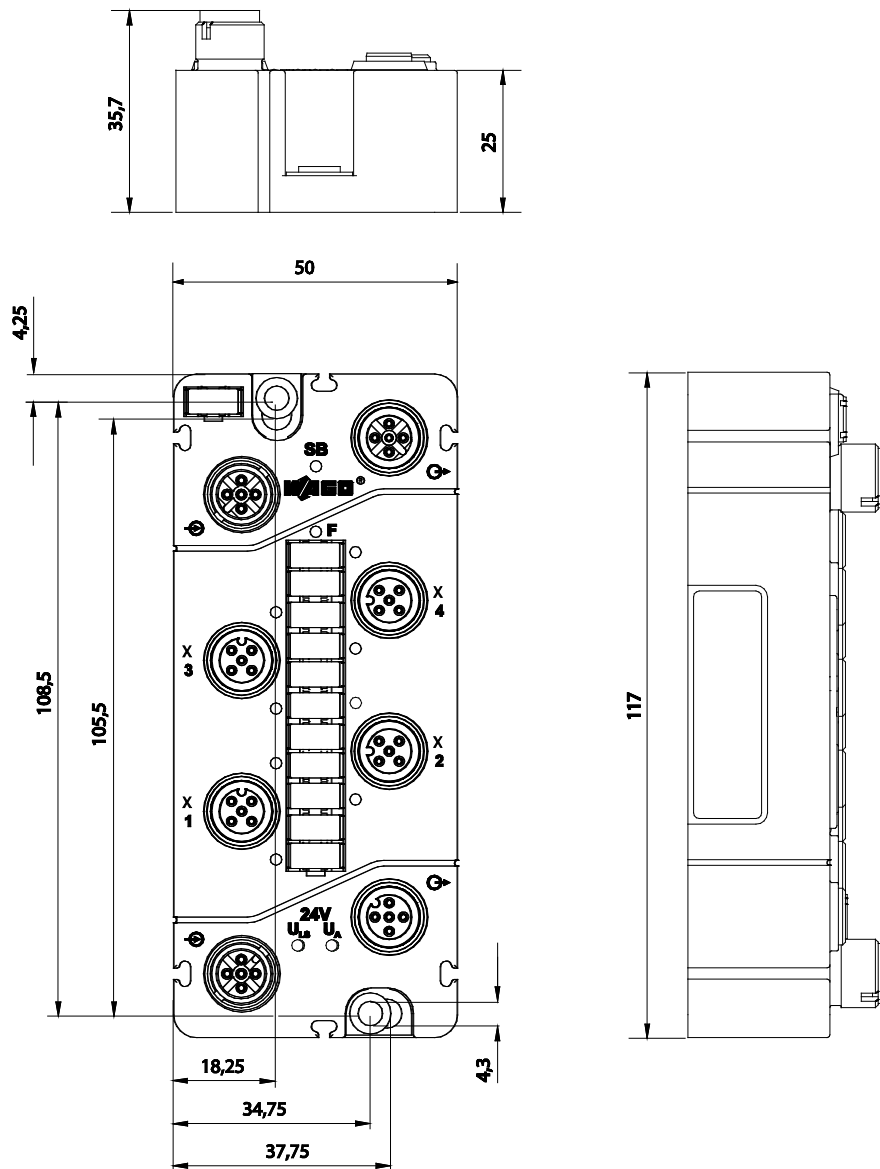

Figure 7: Dimensions of the module in millimeters (exemplary)

## 3.7 Technical Data



### Note

#### Different technical data for applications in hazardous areas!

If the device is used in an application in the hazardous area, the technical data contained in the ATEX/IECEX certificate are binding in this application!

### 3.7.1 Device Data

Table 8: Technical data – Device

Width	50 mm
Height	35.7 mm
Lowness	117 mm
Weight	Approx. 260 g

### 3.7.2 Supply

Table 9: Technical data – Supply

Connection type	M12 connectors, A coded, 4 poles *
Current carrying capacity of supply connections	Maximum 8 A ( $U_{LS}$ : 4 A, $U_A$ : 4 A)
Supply voltage Logic and sensor voltage $U_{LS}$ Actuator voltage $U_A$	DC 24 V (-25% ... +30%) DC 24 V (-25% ... +30%)
Supply current Logic and sensor current $I_{LS}$ Actuator current $I_A$	Typical 75 mA + sensors (max. 400 mA) Typical 25 mA + actuators 2.4 A (4*600 mA) <b>Note:</b> Please note the maximum aggregate current $\leq 4$ A
Protection	Reverse voltage protection for $U_{LS} + U_A$ Short-circuit protection for sensor/actuator supply

\* Derating should be observed!

### 3.7.3 Communication

Table 10: Technical data – Communication

S-BUS connection	Shielded M12 connector, B coded, 5 poles
------------------	---

### 3.7.4 Serial Interfaces

Table 11: Technical data – Serial interfaces

Number of interfaces	2
Connection type	M12 connector, A coded, 5 poles, shielded
Transmission channels	1 RxD/1 TxD (full/half duplex)
Line length, max.	15 m (RS-232) or 1000 m (RS-422/-485)
Baud rate	300 – 115200 Bd
Buffer, In/Out	4096 Byte/4096 Byte

### 3.7.5 Digital Inputs

Table 12: Technical data – Digital inputs

Number of inputs	4
Connection type	M12 connectors, A-coded, 5 poles, shielded
Connection technology	2- or 3-wire
Input filter	Hardware: $\leq 110 \mu\text{s}$ Software: configurable
Input characteristic	Type 2, acc. to IEC 61131-2
Signal voltage (0)	DC -3 V ... +5 V
Signal voltage (1)	DC +11 V ... $U_A$
Input wiring	high-side switching
Input voltage	24 V DC (-3 V DC $< U_{IN} < +30$ V DC) Supply from $U_A$ strongly recommended, recover for voltages $> U_A$
Input current	Typ. 7.3 mA
Connection of 2-wire BEROs	Maximum of 1.5mA standby current permissible
Cable length, unshielded	$\leq 30$ m

### 3.7.6 Input Characteristic

Table 13: Technical data – Input characteristic

Input voltage	Typical input current
$-3 \text{ V} < U_A < 0 \text{ V}$	0 mA
5 V	2.3 mA ... 2.5 mA
11 V	6.4 mA ... 6.7 mA
$24 \text{ V} < U_A < 31.2 \text{ V}$	7.3 mA ... 7.5 mA

### 3.7.7 Digital Outputs

Table 14: Technical data – Digital outputs

Number of outputs	4
Connection type	M12 connectors, A-coded, 4 poles, shielded
Connection technology	2- or 3-wire
Output voltage	$\leq U_A$
Output current (per channel)	0.5 A (max. 0.6 A), short-circuit/overload protection (thermal shutdown)
Voltage drop against $U_A$ at 500 mA	Maximum 0.2 V DC
Output current (module)	Maximum 2 A
Leakage current in OFF state	Typ. 5 $\mu$ A
Output circuit	High-side switching

### 3.7.8 Information for Actuator Selection

Table 15: Technical data – Actuator selection

Delay time HW from 0 to 1 (0 – 90%) from 1 to 0 (0 – 90%)	Typical 90 $\mu$ s (resistive load) Typical 310 $\mu$ s (resistive load)
Rise time from 0 to 1 from 1 to 0	Typical 60 $\mu$ s (resistive load) Typical 45 $\mu$ s (resistive load)
Cable length, unshielded	$\leq 30$ m
Resistance to recovery	$\leq 1.0$ A (error: 1 channel)
Type of load	Inductive, resistive loads and lamps
Switching frequency	Inductive load approx. 20 Hz Resistive load approx. 500 Hz Lamp load approx. 500 Hz
Parallel switching of 2 outputs	For performance enhancement For redundant control of a load
Type of protective circuit	External protection (e.g., recovery diodes)
Output resistance	$< 0.4 \Omega$

### 3.7.9 Effect of Operating States

Table 16: Technical data – Operating states

CPU stop of PLC	Acc. to substitute value strategy
Interruption of field bus	Acc. to substitute value strategy
Interruption of S-BUS	0 V status
Supply voltage under rated voltage tolerance	0 V status
Interruption of supply voltage	0 V status
Output operation	Non-retentive
Overload behavior	Automatic restart

### 3.7.10 Configurable Functions of the Serial Interfaces

Table 17: Technical data – Configurable functions of the serial interfaces

Operating mode (per channel)	RS-232, RS-422/-485 (half/full duplex)
Baud rate (per channel)	300 / 1200 / 2400 / 4800 / 9600 / 19200 / 38400 / 57600 / 115200
Data bits (per channel)	7 / 8
Parity	None / Even / Odd
Stop bits	1 / 2
Flow control	None / Xon+Xoff / RTS+CTS

### 3.7.11 Configurable Functions of the Digital Inputs/Outputs

Table 18: Technical data – Configurable functions of the digital inputs/outputs

Operating mode (per module)	DO / DI / DIO
Input filter (per channel)	0.1 / 0.5 / 3 / 15 / 20 ms / filter off
Inversion (per channel)	ON / OFF
Substitute value strategy (per channel)	Switch substitute value / keep last value
Substitute value (per channel)	0 / 1
Manual mode (per channel)	ON / OFF
Manual mode value (per channel)	0 / 1
Online simulation (by channel)	Lock / unlock, simulation value: 0 / 1
Online simulation (per channel/module)	Diagnostics

### 3.7.12 Diagnostics

Table 19: Technical data – Diagnostics

Per module	Short circuit/overload of field supply
Per channel	Overtemperature (DO)
Per module	Undervoltage ( $V_{LS} + V_A$ )

### 3.7.13 Process Image

Table 20: Technical data – Process image

Process data width (interfaces)	10 byte (data In/Out + status)
Process data width (DIO)	1 byte data In/Out + 1 byte status

### 3.7.14 Indicators

Table 21: Technical data – Indicators

SB: S-BUS status	LED (green/red/orange)
F: Error status	LED (red)
Ch1.1/Ch2.1: Transmission status	LED (yellow)
Ch1.2/Ch2.2: Reception status	LED (yellow/red)
0 ... 3: Input and output signal status	LED (yellow)
0 ... 3: Output diagnostics	LED (red)
$U_{LS} + U_A$ : Supply status	LED (green)
LED indicators:	Non-retentive

### 3.7.15 Isolation

Table 22: Technical data – Isolation

Channel - Channel	No
$U_{LS}$ , $U_A$ , S-BUS	500 VDC each

## 3.8 Approvals

The following approvals have been granted to 767-5203 module:

 Conformity Marking

 cUL<sub>us</sub> UL508

The following Ex approvals are pending for 767-5203 module:



BVS 15 ATEX E098X

II 3 G Ex nA IIC T5 Gc

II 3 D Ex tc IIIB T90°C Dc

IECEX BVS 15.0083X

Ex nA IIC T5 Gc

Ex tc IIIB T90°C Dc

### 3.9 Standards and Guidelines

The module 767-5203 meets the following standards and guidelines:

EC EMC Directive	2004/108/EC
EMC CE-Immunity to interference	acc. to EN 61000-6-2
EMC CE-Emission of interference	acc. to EN 61000-6-4
Ex Directive	94/9/EC
Explosive atmosphere Devices – General requirements	EN 60079-0
Explosive atmosphere Equipment protection by type of protection "n"	EN 60079-15
Explosive atmosphere Equipment dust ignition protection by enclosure "t"	EN 60079-31
Explosive atmospheres General requirements	IEC 60079-0
Explosive atmospheres Equipment protection by type of protection "n"	IEC 60079-15
Explosive atmospheres Equipment dust ignition protection by enclosure "t"	IEC 60079-31

## 4 Mounting

The module can be fastened directly to your system using screws. It can also be mounted on a carrier rail using an adapter or fastened to a profile rail using a surface mounting profile.

For mounting on a flat surface, WAGO offers spacers to assist in the mounting process that can be inserted between the 767 Series components. This helps by providing sufficient mounting distance for compact direct mounting, as well as eliminating gaps where dirt could accumulate. A cable tie can be fastened through each of two mounts in the spacer, which together serve to relieve strain from the sensor or actuator cables.

### 4.1 Information on Mounting

The following information shall always be observed:

- Disconnect the power supply from the system before you start with installation.
- The maximum diameter of the drill hole of the module's mounting holes is not to exceed 4 mm. Otherwise, a full contact with function earth (FE) socket of the module not be guaranteed. This may lead to restrictions in the shielding.
- To protect the module from tensile forces that may arise, do not bridge spaces with it.
- Screw the module down only on flat contact surfaces to protect it from warping.
- Ensure that the connectors are not soiled during installation. Dirt and other such substances damage the contacts, allowing corrosion to develop.
- To avoid damaging the module, do not mount it in shear areas of moving devices.
- Arrange for a sufficient potential equalization in your system.
- Use all mounting holes to mount the module to your system so all FE (function earth) connections lie on a ground potential.

Any mounting position is possible.

---

### **Note**



#### **Ensure a safe mounting position!**

In explosion hazardous environments no increased mechanical loads must be present at the installation location. If shocks are possible, a shock protection must be installed between the module and the possible source of the shock.

---

## 4.2 Tools and Accessories Required for Mounting

Depending on the mounting type, the following tools are required for installation:

- A screwdriver for M4 fixing screws
- Drilling machine to pre-drill the mounting holes for the module to be mounted to the system and, if applicable, for the imperforated carrier rail.
- M4 thread cutter (bottoming tap or hand tap set)

The WAGO accessories listed below are required for mounting. The associated item numbers can also be found in the 767 Series fieldbus manuals, in the "Accessories" section. Select the manual appropriate to the fieldbus you are using.

- Carrier rail adapter, including fixing screws and perforated or imperforated carrier rails (DIN rail 35 x 7.5 or DIN rail 35 x 15) according to EN 60715, also available from WAGO.

or

- Profile adapter, including fixing screws
- Spacer (optional)

Two M4x12 screws are required for direct mounting of the module. The length of the screw shaft is to be selected according to the mounting type.

### Bore measurements

When fastening the 767 Series components without a threaded hole, the clearance hole must not be wider than 4 mm so as to ensure safe contact of the FG (functional ground) connections.

## 4.3 Direct Mounting on Your System

Mount the module directly on a level surface of your system, without using WAGO accessories. Direct mounting of the module is to be carried out as follows:

1. Disconnect the power supply from those devices on which you wish to mount the module.
2. Mark the drill holes using the hole drilling template printed on the packaging. You can also hold the module in the desired position and mark the drill holes. Ensure that there is sufficient space around the 767 Series components to enable you to connect all cable without problems.

### Note



#### Direct Mounting

We recommend using WAGO spacers for compact direct mounting. If these are used, the resulting additional distance from the second 767 Series component is to be noted. See section “Mounting the Module” > “Mounting the Spacer in the Case of Compact Arrangement”.

3. Fasten the module with two M4x12 screws via the two mounting holes.

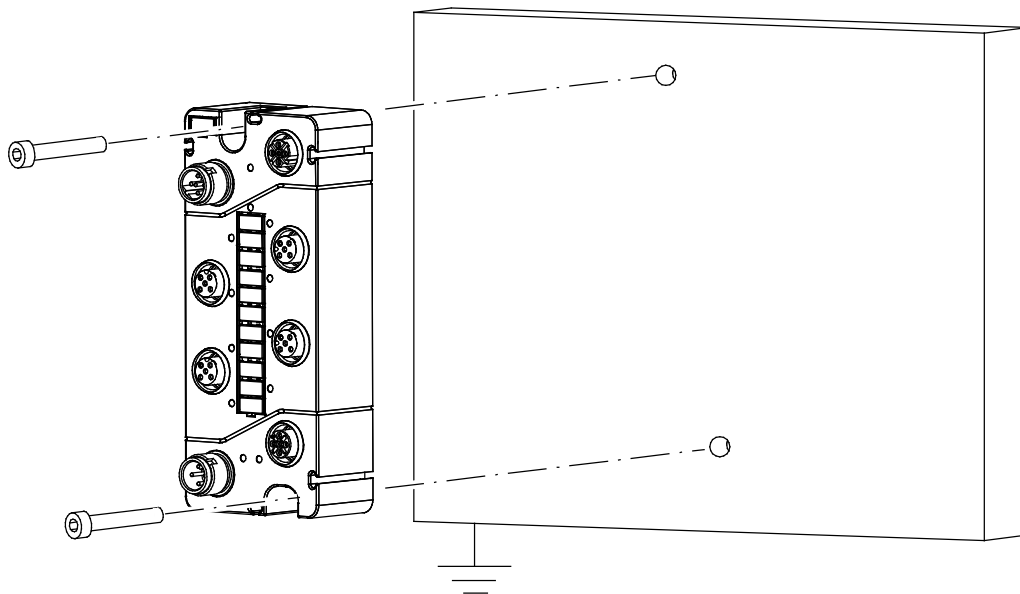

Figure 8: Mounting the module on a grounded frame or to another grounding point

## 4.4 Mounting on a Carrier Rail (only with WAGO Accessories)

### 4.4.1 Fastening the Carrier Rail Adapter to the Module

A carrier rail adapter is required to mount the module on carrier rails.

Screw together the module and carrier rail adapter using the M4 threaded screws provided, as shown in the figure below.

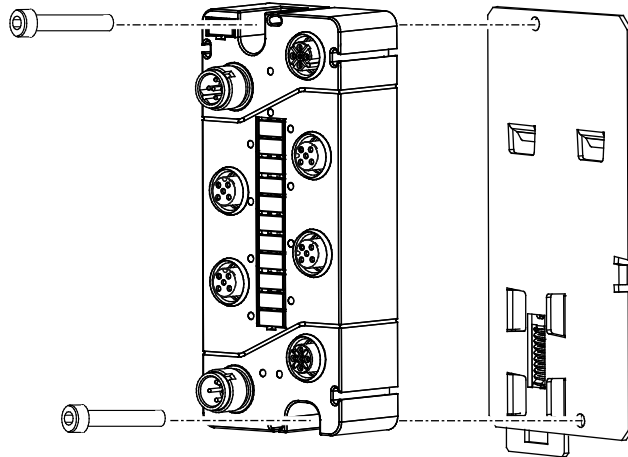

Figure 9: Fastening to the carrier rail adapter

## 4.4.2 Fastening the Module with Carrier Rail Adapter to a Carrier Rail

In order to provide a clear representation, the carrier rail adapter in the figure below is shown without module.

When mounting the module to a carrier rail (DIN rail 35 x 7.5) using a carrier rail adapter, proceed as follows:

1. Disconnect the power supply from those devices on which you wish to mount the module.
2. Set the module onto the edge of the carrier rail (51) with the two notches (50).
3. Press the undersurface against the lower carrier rail edge until the latch (52) locks in place.

### Note



#### Use end stops

When mounting the rail vertically or if shock or vibration loading should occur, the use of end stops (item no.: 249-116 or 249-117) for stabilization is required.

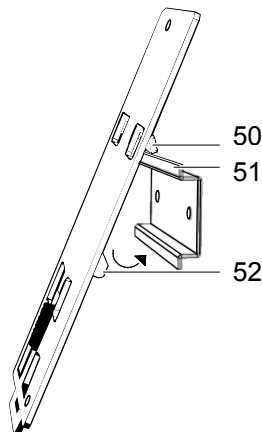

Figure 10: Mounting the carrier rail adapter (exemplary)

## 4.5 Mounting on a Profile Rail (only with WAGO Accessories)

### 4.5.1 Fastening the Profile Adapter to the Module

Aside from using carrier rail adapters to fasten the module, you also have the option to fasten it to a profile rail using the profile adapter and nuts, provided that this mounting type is supported by your system. You are to supply the necessary nuts.

Screw together the module and the profile adapter using the M4 threaded screws provided, as shown in the following figure.

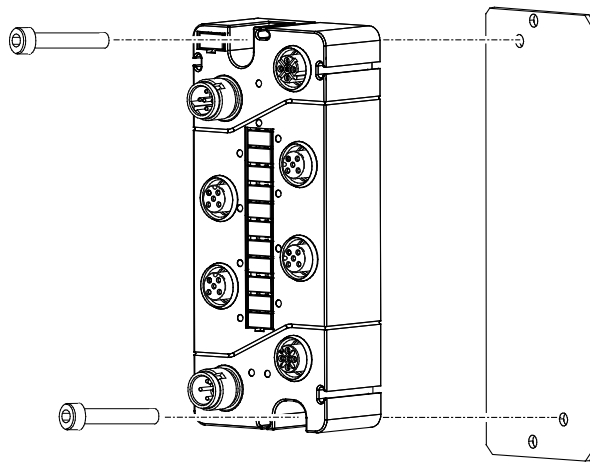

Figure 11: Fastening to the profile adapter

## 4.5.2 Fastening the Module with Profile Adapter to a Profile Rail

To fasten the module to a profile rail of your system, two nuts are required with one screw each (length of screw threads must be compatible with your system).

1. Disconnect the power supply from those devices on which you wish to mount the module.
2. Insert the two screws into the holes above and beneath the fastened module on the profile adapter.
3. Fasten an appropriate nut on each of these screws.
4. Insert the profile adapter with the attached module into the profile rail of your system. Position it and tighten the screws.

## 4.6 Marking and Replacing the Marking Spaces

The module marker card (10) and marking strip (12) are attached when delivered. The protective cover is to be removed when labeling the marking strip. To do this, proceed as follows:

1. Press the slot screwdriver (maximum slot width: 3mm) into the small opening under the marking strip cover (12) and lever it up.
2. Remove the marking strip cover.
3. Mark the marking strip with a waterproof pen.
4. Reinsert the marking strip cover and press it firmly in place.

If the module's marker card (10) must be replaced, proceed in accordance with the step sequence described previously. New module marker cards can be obtained through WAGO.

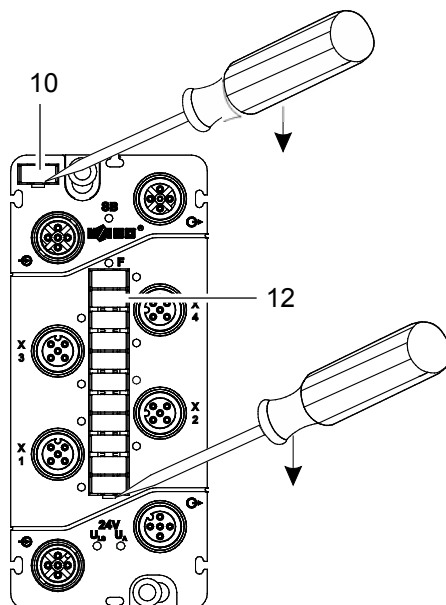

Figure 12: Replacing the marking spaces

## 4.7 Mounting the Spacer in the Case of Compact Arrangement

By using the spacer, a sufficient mounting distance can be achieved when directly mounting the 767 Series components, and gaps can be eliminated where otherwise dirt and other substances could accumulate. In addition, it is possible to optimize the cable routing. For this purpose, two fastening lugs each are included on the spacer for cable ties.

1. Disconnect the power supply from those devices on which you wish to mount the module.
2. The spacer can only be inserted into the appropriate openings of the module from the bottom. To bind both components, place the module on the spacer or push the spacer from the bottom into the module.
3. Fasten the attached components on a flat surface by fastening the module to the grounded frame of your system or to another grounding point with two M4 screws via the mounting holes.

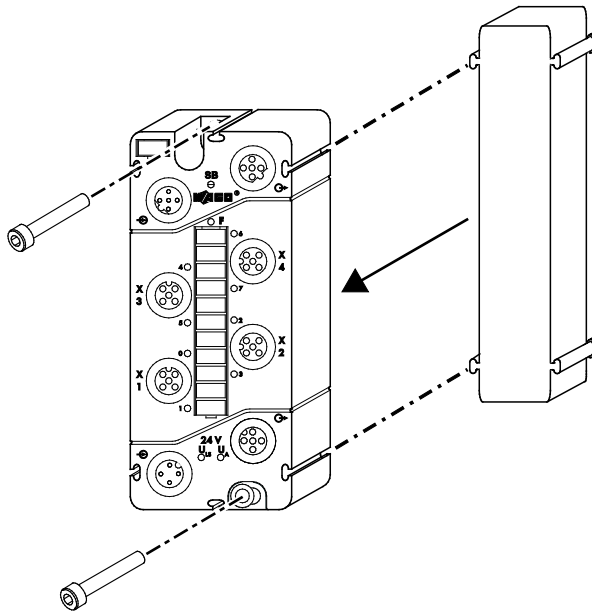

Figure 13: Attaching a spacer to a module

- 4. When attaching 767 Series component, only one 767 component connected with a spacer can be attached and screwed on to the preceding component due to the mounting direction. The last 767 component is fastened without a spacer.

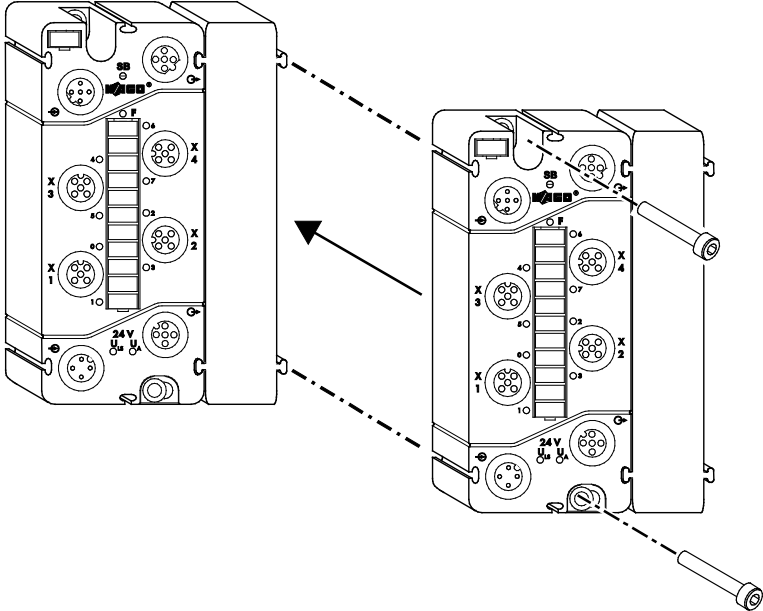

Figure 14: Attaching another module with a spacer

## 5 Connecting Data and Supply Cables

### 5.1 Notes



#### DANGER

##### Electric voltage!

Operate the 767 Series components exclusively with 24 VDC PELV (Protective Extra Low Voltage) or SELV (Safety Extra Low Voltage) voltage sources. Failure to comply may result in electric shock.

#### NOTICE

##### The highest current carrying capacity of the supply contacts is 4 A!

Always observe the maximum current carrying capacity per supply line ( $U_{LS}$ ,  $U_A$ ) for each 767 Series component and the overall power consumption for all 767 components. Neither of these values shall exceed 4 A since an increase in current causes the contacts to overheat and damages the 767 Series components. Information regarding the power demand of each 767 Series component can be found in the corresponding data sheet, which is available from [www.wago.com](http://www.wago.com).

#### NOTICE

##### Exposed connections!

If connections have not been closed with protective caps, liquid or dirt can penetrate the components of the 767 Series module and ruin it. Therefore, close all unnecessary connections with protective caps, which must be ordered separately, in order to maintain the IP67 degree of protection. (See section “Accessories” of the fieldbus coupler/controller manual.)

- The connectors must be disconnected from the power supply when screws are tightened.
- Tighten the connectors by hand. To achieve the required torque (see below) for the connector, use the torque wrench with the order number **206-701**.

<b>Torque for M8 connectors:</b>	<b>0.6 Nm</b>
<b>Torque for M12 connectors:</b>	<b>1.0 Nm</b>

#### NOTICE

##### Use torque wrench 206-701!

Only use the specified torque wrench. Using mechanical tools can cause the threads to strip.

In this case, replace the module!

- For both power supply and S-BUS, use only pre-assembled WAGO system cables so the specified characteristics of the technical data can be achieved.

- Do not use drop lines under any circumstances. This can lead to amplified line reflections and signal distortions, which greatly impair the transmission quality.
- Observe the exact positioning (coding) between plug and socket.
- Keep all cables a sufficient distance away from electromagnetic sources of interference in order to maintain a high level of interference resistance of the 767 system against electromagnetic emissions.
- Observe the minimum bending radiuses of the WAGO system cable. For more information, see the technical data at [www.wago.com](http://www.wago.com).
- When laying all cable, ensure that you do not lay it in shear areas of moving machine parts.
- Observe the correct layout of the potential equalization.

## 5.2 Required Accessories

The WAGO accessories listed below are required for connecting the data and supply cable. The associated item numbers can also be found in the fieldbus manuals for 767 Series, in the "Accessories" section. Select the manual appropriate to the 767 Series fieldbus you are using.

- S-BUS M12 terminator, IP 67
- S-BUS and supply cables, pre-assembled on both ends, IP 67
- Torque wrench
- Protective caps

### 5.3 Connecting the S-BUS Cables

The S-BUS is used for communication between a fieldbus coupler and the connected 767 Series components.

**Requirement:**



- A WAGO S-BUS cable pre-assembled on both ends is readily available to you. This is necessary for optimal signal transmission.
- The S-BUS terminator is available to you, which is necessary for communication.

The following table outlines the assignment of the S-BUS connections:

Table 23: S-BUS connection assignment

Connection		Contact	Description	
			IN	OUT
		1	RD +	TD +
		2	RD -	TD -
		3	TD -	RD -
		4	TD +	RD +
		5	GND	
		Connecting thread		Shield

To connect the S-BUS cables to fieldbus coupler and I/O modules, proceed as follows:

1. Disconnect the power supply from those devices on which you have mounted the module.
2. Connect the S-BUS cable (S1) with the OUT connection  (3) of the fieldbus coupler and the IN connection  (1) of the module. For example, if two I/O modules have been connected to the fieldbus coupler, connect the S-BUS cables (S1, S2) to the associated IN and OUT connections, as shown in the following figure.
3. Tighten the plugs and sockets using the knurled-head screws.
4. Attach the S-BUS terminator (T) to the last I/O module as shown in the figure and tighten it.

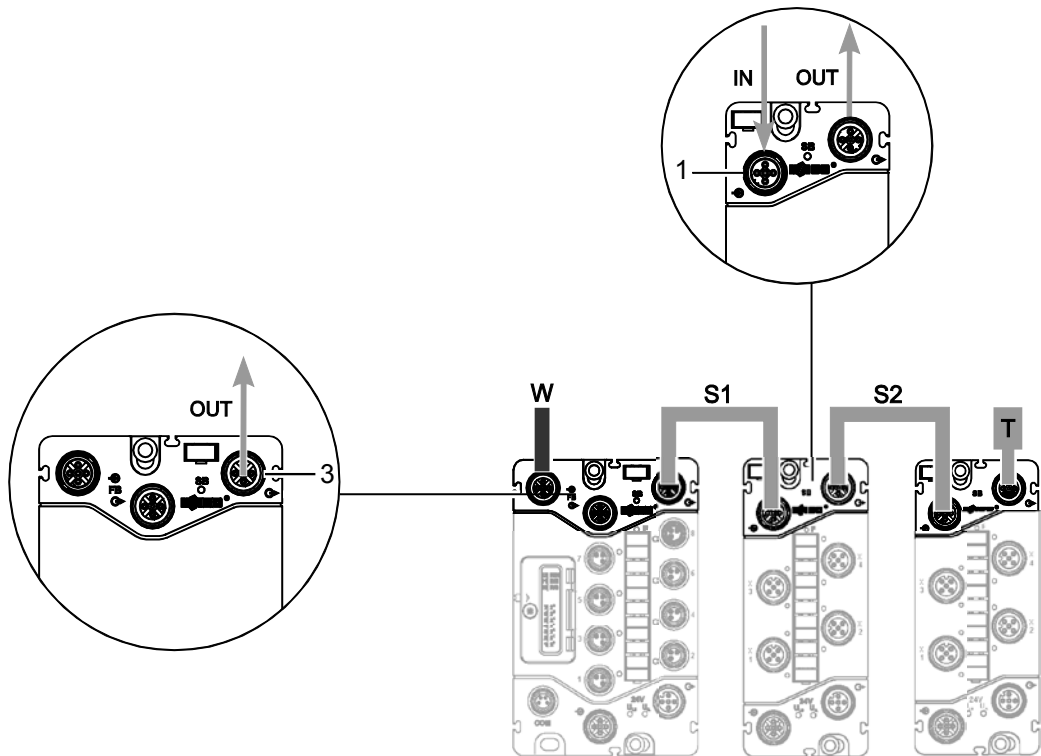

Figure 15: S-BUS connected to a fieldbus coupler and modules

## 5.4 Connecting the Supply Cable

The supply cable provides power to the module.

### Requirement:

The WAGO supply cables K1 and K2, which are pre-assembled on both ends, must be available (see figure on next page).

The following table outlines the assignment of the supply connections:

Table 24: Supply connection assignment

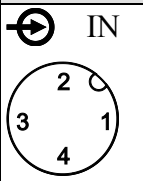
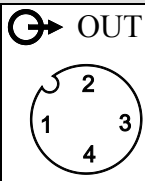

Connection		Contact	Description
		1	24 VDC $U_{LS}$
		2	24 VDC $U_A$
		3	0 V $U_{LS}$
		4	0 V $U_A$

## NOTICE

### The highest current carrying capacity of the supply contacts is 4 A!

Always observe the maximum current carrying capacity per supply line ( $U_{LS}$ ,  $U_A$ ) for each 767 Series component and the overall power consumption for all 767 components. Neither of these values shall exceed 4 A since an increase in current causes the contacts to overheat and damages the 767 Series components. Information regarding the power demand of each 767 Series component can be found in the corresponding data sheet, which is available from [www.wago.com](http://www.wago.com).

To connect the supply cable to the fieldbus coupler and modules, proceed as follows:

1. Disconnect the power supply from those devices on which you have mounted the module.
2. Connect the power supply cable (K1) to the  OUT connection (9) of the fieldbus coupler and the  IN connection (5) of the module.  
For example, if two modules have been connected to the fieldbus coupler, connect the power supply transmission cable (K1, K2) with the associated IN and OUT connections, as shown in the following figure.
3. Tighten the plugs and sockets using the knurled-head screws.
4. Screw a protective cap on all unused ports to ensure that IP 67 degree of protection is provided

Information on connecting the power supply cable (K0) to the "IN" port  (6) of a fieldbus coupler can be found in the appropriate manuals.

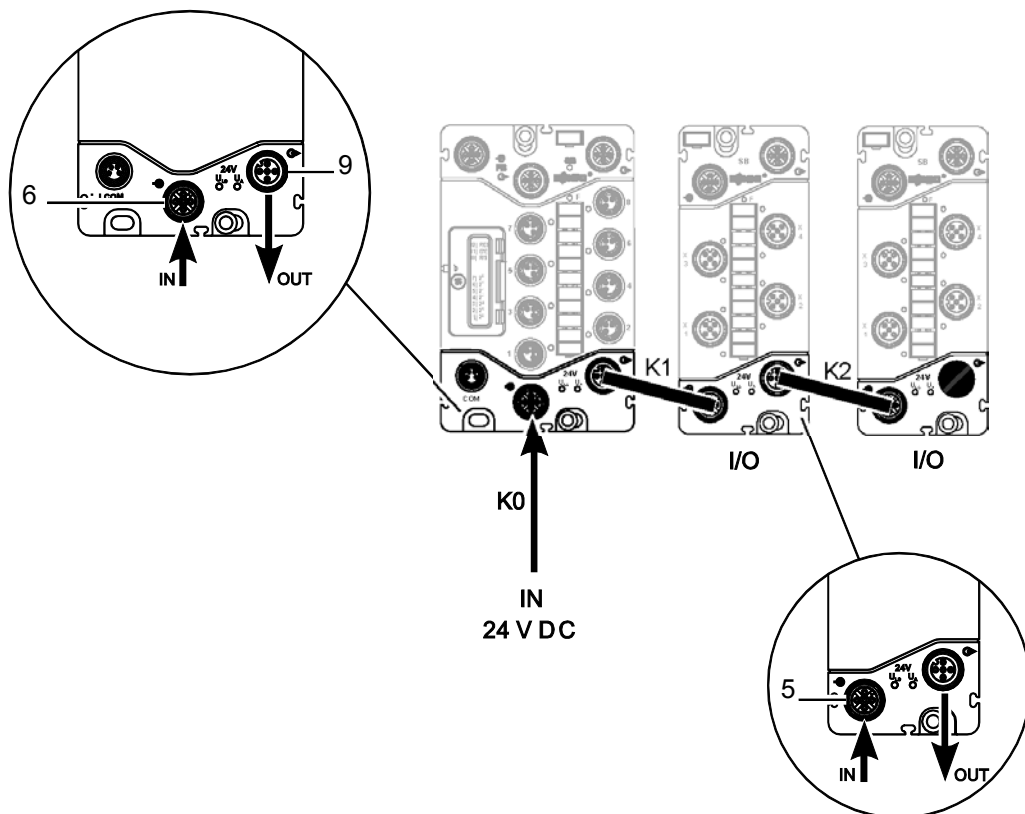

Figure 16: Supply cable connected to a fieldbus coupler and modules

## 5.5 Connecting Interface Cables

The interface cables are used to connect external devices with a serial interface.

When using cables that have not been pre-assembled, make sure that these cables are equipped with M12 plugs rated to IP67. The following table outlines connection assignments:

Table 25: Serial interfaces: Pin assignment

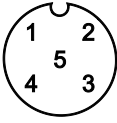
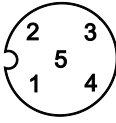
Connection		Pin assignment		
IN/OUT	IN/OUT	Pin	RS-232	RS-485/RS-422
 X3	 X4	1	RTS	TX+ / Y
		2	TxD	TX- / Z
		3	CTS	RX+ / A
		4	RxD	RX- / B
		5	GND	GND
		Housing	Shield (screen)	Shield (screen)

To connect the external devices to the serial interfaces (X3 or X4), process as follows:

1. Disconnect the power supply from those devices on which you have mounted the module.
2. Insert the plug of the connection cable to the socket of a serial interface (3) of the module and tighten using the knurled-head screw.
3. Screw a protective cap on all unused connections to ensure that the IP67 degree of protection is adhered to.

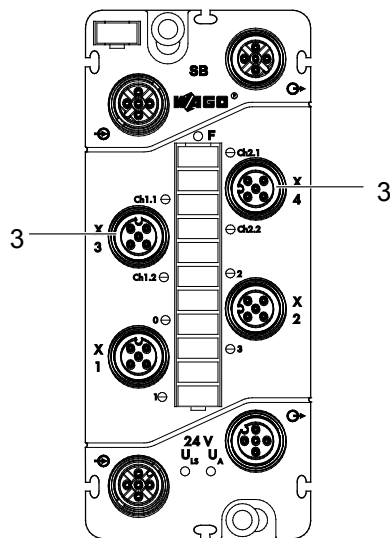

Figure 17: Connectors of interfaces

## 5.6 Connecting Sensor/Actuator Cables

The sensor/actuator cable provides power to the connected sensors and actuators.

When using cables that have not been pre-assembled, make sure that these cables are equipped with M12 plugs rated to IP67. The following table outlines the assignment of the sensor/actuator connections:

Table 26: Digital inputs and outputs: Pin assignment

Connection		Connection Scheme
IN/OUT	IN/OUT	<p>1: 24 V 3: 0 V <math>U_A</math></p> <p>5: n.c.</p> <p>4: In-/Output A 2: In-/Output B</p> <p>Housing: Shield</p>

### NOTICE

**The highest current carrying capacity of the supply contacts is 4A!**

Ensure that the actuators from the  $U_A$  supply line are supplied with power. The actuator's power consumption must be taken into consideration when determining the current power demand for the  $V_A$  supply line.

### NOTICE

**Inputs/outputs have limited feedback protection!**

Please note the maximum feedback current of 1A per input/output pin. It is strongly recommended to feed input signals from  $U_A$ .

To connect the sensors/actuators to the digital inputs and outputs, proceed as follows:

1. Disconnect the power supply from those devices on which you have mounted the module.
2. Insert the plug of the sensor or actuator cable into the socket of a digital input/output (4) of the module and tighten it using the knurled-head screw.
3. Screw a protective cap on all unused connections to ensure that the IP67 degree of protection is adhered to.

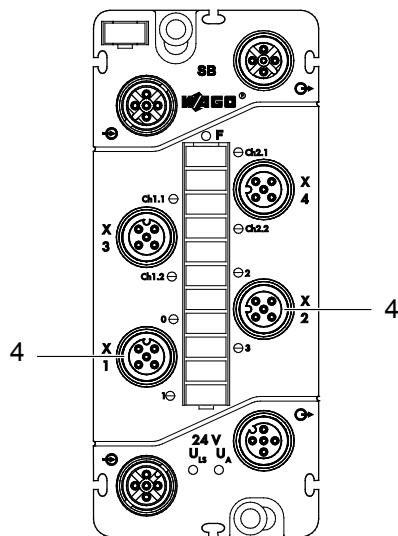

Figure 18: Connectors of sensors/actuators

## 6 Commissioning

### NOTICE

#### **Exposed connections!**

If connections have not been closed with protective caps, liquid or dirt can penetrate the components of the 767 Series module and ruin it. Therefore, close all unnecessary connections with protective caps, which must be ordered separately, in order to maintain the IP67 degree of protection. (See section "Accessories" of the fieldbus coupler/controller manual.)

Before starting up the 767 node, ensure that the following requirements are met:

- Both 767 Series Fieldbus Coupler and Module 767-5203 have been properly mounted (See also fieldbus coupler manuals Series 767).
- The fieldbus, all necessary supply and sensor lines, and the S-BUS bus terminator are all securely fastened onto the appropriate connections (see section "Connecting Data and Supply Cables").
- An appropriate potential equalization is implemented in your system.
- Shielding is carried out properly.

## 7 Parameterizing

All parameters listed here can be set using WAGOframe (or another FDT/DTM frame application) for the module.

If you use a fieldbus for the parameterization, only certain parameters are configurable, depending on the type of fieldbus.

---

### **DANGER**

#### **Changing parameters!**

When parameters are incorrectly modified via FDT/DTM frame application (e.g., WAGOframe), machine components could be placed in a dangerous state and personnel and machines could be at risk.

Before changing the parameters, ensure that the machine components are in a safe and defined state and switch off the higher-level controller.

Also ensure before start-up that no personnel remain in the danger area of the machine components.

---

For the parameterization of the module, an appropriate DTM is available. Via this DTM, you can parameterize the module either online or offline. The offline mode enables the parameterization of a module that is not yet present. In the offline mode, first store the parameters in a project and later transfer them to the module.

In the online mode there is a direct link between the display and the connected module. If the module is in the online mode, its name is displayed in **bold** and *italic* font in the network window.

---

### **Note**



#### **Detailed informations.**

Detailed information on handling WAGOframe can be found in the fieldbus coupler manuals.



---

The following sections provide information on the parameters and their descriptions.

To open the parameterization user interface (DTM) of the module, double-click on the module in the "Network View" of WAGOframe. The parameterization user interface can also be opened by right-clicking on **Offline Parameter** or **Online Parameter** in the context menu.

If several DTMs are open, select one via the corresponding tabs. Depending on the DTM you have selected, different buttons are provided:

Table 27: DTM buttons

Buttons	Description
<b>[Read]</b> (Online mode only)	Reads and displays the parameters found in the module.
<b>[Write]</b> (Online mode only)	Writes the modified values to the module.
<b>[Close]</b> (Online and offline mode)	Closes the parameterization user interface (DTM).
<b>[Apply]</b> (Offline mode only)	Applies the entries in the project. Please note that the project should also be subsequently saved ( <b>File &gt; Save</b> ).
<b>[Help]</b> (Online and offline mode)	Opens the online help for an entry that has been previously selected in the DTM (e.g., digital inputs, global setting).
	Shows/hides parameter overview.
	Displays the product data sheet. A PDF reader must be installed on your PC.
	Opens the DTM online help.

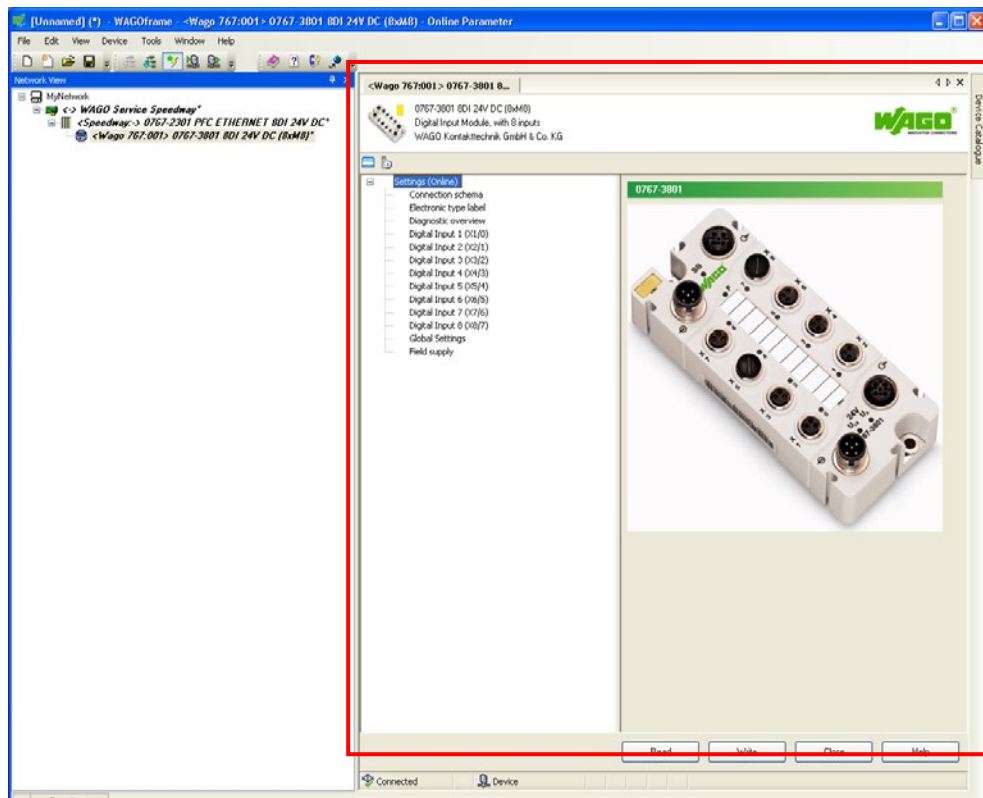

Figure 19: Example of an open DTM, including parameters

## 7.1 Electronic Type Label

Table 28: Information on the module

Parameter	Description
Vendor	Manufacturer
Release index	FW.HW.FL <b>FW:</b> Actual firmware release index. When updating the firmware, please note that the firmware release index may not be conformed to the printed firmware release index on the side of the fieldbus coupler. <b>HW:</b> Hardware release index <b>FL:</b> Firmware loader release index
Firmware revision	General information on the module
Order number	
Description	
Serial number	
Date of production	
Designation	Electronic marking field

## 7.2 Diagnostic Overview

The currently pending diagnostics existing on the module are displayed here. In this view of the DTM, you can enable simulation of the diagnostics, as well as disable transmission of the diagnostics. When disabling transmission, make sure that the display behavior of each LED changes that indicates the specific diagnostics (section "Diagnostics" > "LED Signaling"). The diagnostic overview is only available in online mode.

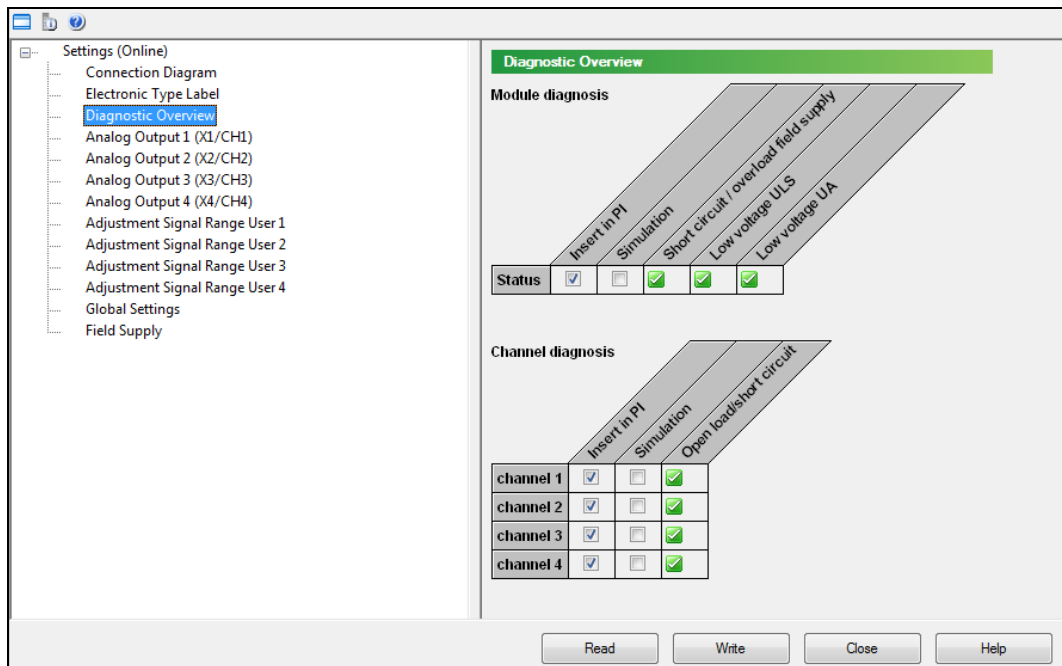

Figure 20: Example of the diagnostic overview of a module (information may differ from the actual module)

Table 29: Diagnostics setup

Parameter	Description
Insert in PI	By unselecting the checkbox, you specifically suppress evaluation and transmission of individual diagnostics. Doing so has no effect on the size of the process image. Even if a diagnostics has occurred, the diagnostic value "0" (no error) is transmitted to the higher-level controller.
Simulation	If you have selected the "Insert in PI" checkbox, the "Simulation" parameter is released. You can select the diagnostics you want to simulate. Click the <b>[Write]</b> button to transfer the simulated values to the module.
Status	Displays whether there is a diagnostics: X mark: There is a diagnostic message. Check mark: There is no diagnostic message.

Table 30: Information about existing module diagnostics



Global Diagnostics	
Diagnostics	Description
Low voltage $U_{LS}$	<p> <b>WARNING</b></p> <p><b>Disabling the outputs</b> If there is an undervoltage of <math>U_A</math> and/or <math>U_{LS}</math>, the module outputs are disabled. Machine components can be placed in a dangerous condition, as well as personnel and machine put in danger.</p> <p>If an undervoltage of the logic and sensor supply (<math>U_{LS}</math>) of <math>&lt; 18\text{ V}</math> occurs on the module, the outputs are disabled and a corresponding diagnostic is transmitted to the fieldbus coupler. The serial interfaces are disabled. The F-LED of the module illuminates.</p>
Low voltage $U_A$	<p> <b>WARNING</b></p> <p><b>Disabling the outputs</b> If there is an undervoltage of <math>U_A</math> and/or <math>U_{LS}</math>, the module outputs are disabled. Machine components can be placed in a dangerous condition, as well as personnel and machine put in danger.</p> <p>If an undervoltage of the actuator supply (<math>U_A</math>) of <math>&lt; 18\text{ V}</math> occurs on the module, the outputs are disabled and a corresponding diagnostic is transmitted to the fieldbus coupler. The serial interfaces are disabled. The F-LED of the module illuminates.</p>
Short circuit/ overload encoder supply	The module has detected a short circuit or overload of the encoder supply (only possible when field supply is switched on).

Table 31: Information about existing channel diagnostics

Channel Diagnostics	
Diagnostics	Description
Overtemperature	The module has identified overheating on the corresponding channel (1 – 8) (only enabled when the actuator output is switched on).



## Note

### Interruption of the S-BUS

If there is an interruption of the S-BUS, the module is automatically put in STOP mode. The module outputs are disabled.

## 7.3 Input and Output Parameters

### Selecting the Connection Mode

Specify in which operating mode the connection should be operated. Each connection can be configured individually as a digital input or output.

Table 32: Overview of the connection mode

Parameter	Description
Connection mode	Digital output Operation of the respective connection as a digital output.
	Digital input Operation of the respective connection as a digital input.

### 7.3.1 Connection Mode "Digital Output"

Table 33: Overview of adjustable parameters for the digital outputs

Parameter	Description
Connection mode	Mode display
Designation	Electronic marking field (max. 40 characters)
Output value	The output state is indicated in this field.
Process image value	This field indicates the value of the output process image for this output. When manual operation is activated, the field becomes a checkbox. Activate the checkbox to output the state "1" on the output independent of the control unit.
Signal Inversion	Here you can release the current process value as an inverted output value.  <b>Checkbox deactivated*:</b> Output signal is output as shown in the process image <b>Checkbox activated:</b> Output signal is output inverted as shown in the process image
Substitute value strategy	This releases the substitute value or the last output value in cases such as a fieldbus interruption. You have the following options: - Switch to substitute value* - Keep last value**
Substitute value	Enter the process value that is output in case of error. In case of error (e.g., fieldbus interruption), the value is used with the "Switch to substitute value" substitute value strategy.  <b>Checkbox deactivated:</b> 0* <b>Checkbox activated:</b> 1
Manual Operation	Activate the checkbox to define the output value independent of the control unit. When manual operation is activated, the field for the process image value becomes a checkbox for the manual operation value.
Diagnostic Simulation	Activate the checkbox to switch diagnostic simulation on. When the simulation is switched on, the fields for the diagnoses become checkboxes.
Restart mode Actuator	Set the restart behavior of an enabled output if the output has been disabled due to the "Overtemperature" diagnosis. You have the following options: - Delayed* After the time set has elapsed ("Restart delay, actuator"), the output is switched on again automatically. - Diagnosis acknowledgement The output is only switched on after acknowledging the diagnostic message. Acknowledge the diagnostic message from the higher-level control unit or PLC. The respective coupler manual specifies which fieldbus couplers this functionality supports.  <b>Information about diagnostic acknowledgement:</b> When using fieldbus couplers that do not support the diagnostic acknowledgement, disabled outputs may remain OFF.

Table 33: Overview of adjustable parameters for the digital outputs

Parameter	Description
Restart delay, actuator	<p>Time in 100 ms intervals, after which a disabled output is switched on again in case of error.</p> <p>You must deactivate the checkbox under "Restart mode, actuator" (0). <i>Default setting: 10 * 100 ms = 1000 ms</i></p> <p><b>Note:</b> If you set the time of the "Restart delay, actuator" parameter to 0 ms, the I/O LED appears yellow instead of red if a short circuit or overload appears due to the short restart interval (see section "Diagnostics").</p>
Overtemperature	When the checkbox is activated, there is an overtemperature on the respective channel (only enabled when the actuator output is switched on).

\* Default

\*\* The last value is the value output to the contact before occurrence of the respective interruption. For example, this can be a process value or "manual operation value".

## 7.3.2 Connection Mode "Digital Input"

Table 34: Overview of adjustable parameters for the digital inputs

Parameter	Description
Connection mode	Mode display
Designation	Electronic marking field (max. 40 characters)
Input value	The input state is indicated in this field. When simulation is activated, the field becomes a checkbox. Activate the checkbox to simulate the state "1" in the process image independent of the input.
Signal Inversion	You can invert the currently pending input signal here.  <b>Checkbox deactivated*:</b> Input signal is mapped in the process image as attached to the input <b>Checkbox activated:</b> Input signal is mapped inverted in the process image
Filter time	Set the input filter for the measured signals here. You have the following options: - None - 0.1 ms - 0.5 ms - 3 ms* - 15 ms - 20 ms
Substitute value strategy	This is used, for example, to transfer the substitute value or the last input value in the event of a low voltage $U_A$ . You have the following options: - Switch to substitute value* - Keep last value**
Substitute value	Here you can enter the process value that is transmitted in the case of an error. In case of error (e.g. low voltage $U_A$ ), the value is used with the "Switch to substitute value" substitute value strategy.  <b>Checkbox deactivated:</b> 0* <b>Checkbox activated:</b> 1
Simulation input value	Activate this checkbox to switch input simulation on. The field for the input value then becomes a checkbox for the simulation value.

\* Default

\*\* The last value is the value output to the contact before occurrence of the respective interruption. This can be, for example, an input value or a "simulation value".

## 7.4 Parameters of the Serial Interfaces

Table 35: Parameters of the serial interfaces

Parameter	Description
Simulation	<p>Activate this checkbox to switch on the interface simulation. When the simulation is activated, the display boxes for "Status CTS Flow Control", "TX Buffer Full" and "RX Buffer Full" switch to checkboxes for the respective simulation value. In addition, an input box for the input data to be simulated appears on the Input buffer, serial interface page.</p> <p><i>Default setting: deactivated</i></p>
Manual Operation	<p>Select this checkbox to define the output data independent of the control unit. When manual operation is activated, the display box for "Status RTS Flow Control" is switched to a checkbox for the manual operation value. In addition, an input box for the output data to be sent appears on the Output buffer, serial interface page.</p> <p><i>Default setting: deactivated</i></p>
Designation	<p>Enter a designation for the connection. Up to 40 characters can be entered.</p>
Mode	<p>In this box, select the operating mode. You can select the following settings. **</p> <ul style="list-style-type: none"> <li>- RS-232</li> <li>- RS-422/-485 half-duplex*</li> <li>- RS-422/-485 full-duplex</li> </ul>
Baud rate	<p>In this box, select the baud rate. You have the following options:</p> <ul style="list-style-type: none"> <li>- 300</li> <li>- 1200</li> <li>- 2400</li> <li>- 4800</li> <li>- 9600*</li> <li>- 19200</li> <li>- 38400</li> <li>- 57600</li> <li>- 115200</li> </ul>
Data bits	<p>In this box, select the number of data bits. You have the following options***:</p> <ul style="list-style-type: none"> <li>- 7 data bits</li> <li>- 8 data bits*</li> </ul>
Parity	<p>In this box, select the parity setting. You have the following options****:</p> <ul style="list-style-type: none"> <li>- none*</li> <li>- even</li> <li>- odd</li> </ul>
Stop bits	<p>In this box, select the number of stop bits. You have the following options:</p> <ul style="list-style-type: none"> <li>- 1 Stop bit*</li> <li>- 2 Stop bits</li> </ul>

Table 35: Parameters of the serial interfaces

Parameter	Description
Flow control	<p>In this box, select the type of flow control. You have the following options*****:</p> <ul style="list-style-type: none"> <li>- none*</li> <li>- XOn/XOff</li> <li>- RTS/CTS</li> </ul>
State CTS Flow Control	<p>In this box, the CTS state of an attached device appears. The box is active if the external device has activated the CTS line or for flow control XOn/XOff, the XOff tag has been sent.</p> <p>This box is inactive if the CTS line is not activated or when the external device has enabled data traffic again with XOn after being previously locked with XOff.</p> <p>If the simulation is activated, the box changes to a checkbox. Any state can now be simulated independent of the interface state.</p>
State RTS Flow Control	<p>In this field, the RTS state of the interface appears. The box is active if the RTS line has been activated or the XOff tag was sent when selecting flow control XOn/XOff.</p> <p>This box is inactive if the RTS line is not activated or when data traffic has been enabled again by sending an XOn tag after data traffic was previously locked with XOff.</p> <p>When activating manual operation, the box changes to a checkbox. Control is then possible independent of control of the state of the RTS line. If the interface is set to XOn/XOff, activating the box causes the XOff tag to be sent once. Deactivating the box causes the XOff tag to be sent once.</p>
TX Buffer Full	<p>In this box, the state of the output buffer appears. If the box is selected, the output buffer is full and no more data can be sent to the module until data has been reduced via the serial interface.</p> <p>When the simulation is switched on, this box changes to a checkbox in order to simulate any state.</p>
RX Buffer Full	<p>In this box, the state of the reception buffer appears. If the box is selected, the reception buffer is full and no more data can be received from the module until data has been reduced via the fieldbus.</p> <p>When the simulation is switched on, this box changes to a checkbox in order to simulate any state.</p>

\* Default

\*\* RS-422/RS-485 is not available if RTS/CTS has been selected under Flow Control.

\*\*\* 7 data bits is only available if even or odd parity is selected.

\*\*\*\*'none' is only available if 8 data bits was previously selected.

\*\*\*\*\* RTS/CTS is only available if the operating mode of the interface is set to RS-232.

## 7.4.1 Input Buffer, Serial Interface

Table 36: Input buffer, serial interface

Parameter	Description
Display mode	In this box, select the display type for the data. You have the following options:  - ASCII* - Hexadecimal
Data	In this box, the data last received appears. The display is limited to max. 119 characters.
Input in ASCII	This box appears if you have selected the simulation for the serial interface on the Settings page and the display mode is set to ASCII. You can enter up to 119 characters in this box, which are then transferred to the control unit independent of any attached device. If you enter more than the allowed number of characters, a red exclamation mark appears next to the input box.
Input in hexadecimal	This box appears if you have selected the simulation for the serial interface on the Settings page and the display mode is set to hexadecimal. You can enter up to 119 characters in this box, which are then transferred to the control unit independent of any attached device. If you enter more than the allowed number of characters, a red exclamation mark appears next to the input box. In this mode, the individual characters must be separated by a semicolon. Numbers not preceded by "0x" are interpreted as decimal characters and automatically converted to hexadecimal display.

## 7.4.2 Output Buffer, Serial Interface

Table 37: Output buffer, serial interface

Parameter	Description
Display mode	In this box, select the display type for the data. You have the following options:  - ASCII* - Hexadecimal
Data	In this box, the data last sent by the control unit to be output by the interface appears. The display is limited to max. 119 characters.
Input in ASCII	This box appears if you have selected manual operation for the serial interface on the Settings page and the display mode is set to ASCII. You can enter up to 119 characters in this box, which are then transferred to an attached device independent of the control unit. If you enter more than the allowed number of characters, a red exclamation mark appears next to the input box.
Input in hexadecimal	This box appears if you have selected manual operation for the serial interface on the Settings page and the display mode is set to hexadecimal. You can enter up to 119 characters in this box, which are then transferred to an attached device independent of the control unit. If you enter more than the allowed number of characters, a red exclamation mark appears next to the input box. In this mode, the individual characters must be separated by a semicolon. Numbers not preceded by "0x" are interpreted as decimal characters and automatically converted to hexadecimal display.

## 7.5 Global Settings

Table 38: Overview of parameters for the entire module

Parameter	Description
Simulation diagnostic	If the checkbox is selected, you can simulate a low voltage diagnostic. To generate a low voltage diagnostic, one or both of the two checkboxes "Low voltage $U_{LS}$ " and "Low voltage $U_A$ " must be selected. <i>Default setting: unselected</i>
Low voltage $U_{LS}$	In the case of an undervoltage of the logic and sensor supply ( $U_{LS}$ ) or the actuator supply ( $U_A$ ), the corresponding diagnostic is displayed here.
Low voltage $U_A$	

## 7.6 Parameters of Field Supply

Table 39: Overview of adjustable parameters for the field supply

Parameter	Description
Enable field supply	Switch on the field supply (24VDC) here. <i>Default setting: selected</i>
Autorestart delay	In the event of a short circuit, the sensor supply is switched off for a certain time. Here, enter this delay time (in 100 ms increments) after which the sensor supply is restarted. If the short circuit still exists, the process is repeated.
Simulation diagnostic	The simulation can be used to simulate a short circuit. <i>Default setting: unselected</i>
Short circuit/overload	If simulation is deactivated, the respective error is displayed upon emergence. If simulation is activated, you can simulate one of the errors by selecting the appropriate parameter.

## 7.7 Automatic Storage of System Parameters

Some fieldbus couplers provide the "System Parameter Handling" feature. This serves to identify changes to the configuration of a 767 Series node and to the automatic configuration of the I/O modules. When an I/O module must be replaced due to a defect, you do not need to reconfigure the new I/O module. The stored parameters are automatically transferred to the new I/O module. Detailed information on this procedure can be found in the fieldbus coupler manuals in the "Parameter Setting via FDT/DTM" section.

## 7.8 Updating the Firmware

When updating the module firmware, the saved module parameters can be overwritten. Therefore, check your existing configuration after updating the firmware.

## 8 Process Image

The process images for the module listed in the following sections describe the data length on the S-BUS (system bus). The implementation of the S-BUS process images onto the respective fieldbus process images can be found in the fieldbus coupler manuals.

The process image is divided into two areas: an output data area and an input data area. The process image can contain process data with and without diagnostic information, independently of whether the transmission of synchronous diagnostic information has been selected.

---

### Note



#### Synchronous diagnostic information

Synchronous diagnostic information designates the cyclical transmission of diagnostic information in the process image. This is not selected in the original factory settings for the module.

This is only possible when using a fieldbus coupler that supports the synchronous diagnostic function (e.g. 767-1101 or 767-2301). Detailed information about enabling the transmission of diagnostic information can be found in the manual for the fieldbus coupler being used: see the section about the device description file.

In addition, you can also switch on synchronous diagnostic information in fieldbus couplers that support this function by using an FDT/DTM frame application (e.g. WAGOframe) in the corresponding DTM. For more information, see the Section "Parameterization via FDT/DTM" > "Diagnostics setting" in the fieldbus coupler manuals.

---

### Note



#### Activate module diagnostics

You can enable or suppress the individual module diagnostics. For more information, see the Section "Diagnostics Overview".

---

### Note



#### Diagnostic Actuator short circuit/overload

The "Actuator short circuit/overload" diagnostic is dependent on the switching status of the outputs (see section "Diagnostics" > "Diagnostic overview").

---

## 8.1 Input Data

The image for the process data sent to the fieldbus coupler from the I/O module is 11 bytes. If you parameterize synchronous diagnostic data for the I/O module, the process image increases to 12 bytes.

The structure of the bytes is shown in the following table:

Table 40: Input data in the process image

Byte 0	7                 0	Flow control, serial interface 1
	<div style="text-align: center;"> </div>	1 <sub>B</sub> : CTS to interface 1 1 <sub>B</sub> : Output buffer full, interface 1 1 <sub>B</sub> : Reception buffer full, interface 1 1 <sub>B</sub> : Confirmation buffer reset, interface 1 1 <sub>B</sub> : Output buffer empty, interface 1 Reserved
Byte 1	7                 0	Flow control, serial interface 2
	<div style="text-align: center;"> </div>	1 <sub>B</sub> : CTS to interface 2 1 <sub>B</sub> : Output buffer full, interface 2 1 <sub>B</sub> : Reception buffer full, interface 2 1 <sub>B</sub> : Confirmation buffer reset, interface 2 1 <sub>B</sub> : Output buffer empty, interface 2 Reserved
Byte 2	7                 0	Data of serial interfaces 1 and 2 (MBX-2 protocol)
	⋮	
Byte 9	63                 56	Data of serial interfaces 1 and 2 (MBX-2 protocol)
Byte 10	7                 0	Digital inputs (process data)
	<div style="text-align: center;"> </div>	1 <sub>B</sub> : Input value = True

Byte 11	7							0	Diagnostic message

## 8.2 Output Data

The image for the process data sent from the fieldbus coupler to the I/O module is 11 bytes. If you parameterize synchronous diagnosis confirmation for the I/O module, the process image increases to 12 bytes.

The structure of the bytes is shown in the following table:

Table 41: Output data in the process image

Byte 0	7							0	Flow control, serial interface 1
Byte 1	7							0	Flow control, serial interface 2

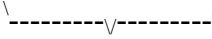
Byte 2	7	0	Data of serial interfaces 1 and 2 (MBX-2 protocol)
	⋮		
Byte 9	63	56	Data of serial interfaces 1 and 2 (MBX-2 protocol)
Byte 10	7	0	Digital outputs (process data)
	 1 <sub>B</sub> : Output value = True		
Byte 11	7	0	Diagnostic confirmation
			1 <sub>B</sub> : Short circuit/overload of the field supply on one or more channels (X1 ... X2) confirmed
			Reserved
			1 <sub>B</sub> : Undervoltage U <sub>LS</sub> confirmed
			1 <sub>B</sub> : Undervoltage U <sub>A</sub> confirmed
			1 <sub>B</sub> : Overtemperature on channel 1 confirmed
			1 <sub>B</sub> : Overtemperature on channel 2 confirmed
			1 <sub>B</sub> : Overtemperature on channel 3 confirmed
			1 <sub>B</sub> : Overtemperature on channel 4 confirmed

## 9 Serial Interface

The module has two serial interfaces accessible from a uniform programming interface. Function blocks are available for CODESYS V3 and Simatic Step 7 to simplify control.

In addition, the serial interfaces can be access completely programmatically.

### 9.1 Function Block CODESYS V3

The function block with description is installed with current versions of CODESYS V3. Both are available to download from the WAGO site on the Internet:

<http://www.wago.com>

### 9.2 Function Block Simatic S7

To obtain the current version of this function block, please contact WAGO Support.

### 9.3 Programmatic Data Transfer

The data of the serial interface is transferred via the so-called MBX2 protocol (Mailbox 2). A description of the protocol is available in the appendix.

#### Note



##### Protocol ID

The protocol ID to be used is 0x00.

Communication with the module is message-based, i.e. a set of output data is transferred to the mailbox as a block and then transferred to the module. Received data also arrives at the control unit a a block.

The block size is only limited by the configured mailbox size (see documentation). However, it is recommended that messages be limited to a length of 120 bytes. The module itself always sends messages to the control unit with a maximum size of 120 bytes.

As shown in the section "Process Image", there is a range of 8 bytes in the process image that is available for transferring serial data. The mailbox ensures that messages, i.e. blocks of bytes larger than this range, are automatically split and recompiled at the end point.

The interface is selected by adding an interface selection byte to the front of the data to be sent.

Table 42: Selection byte for the interface

Selection byte	Interface
0x00	1
0x01	2

An example is available in the next section.

## Note



### Reset clears output and reception buffers!

If the mailbox is reset or reinitialized (see mailbox documentation), the output and reception buffer of the module are cleared.

### 9.3.1 Example of Message Processing

In this example, a dataset is sent to interface 1.

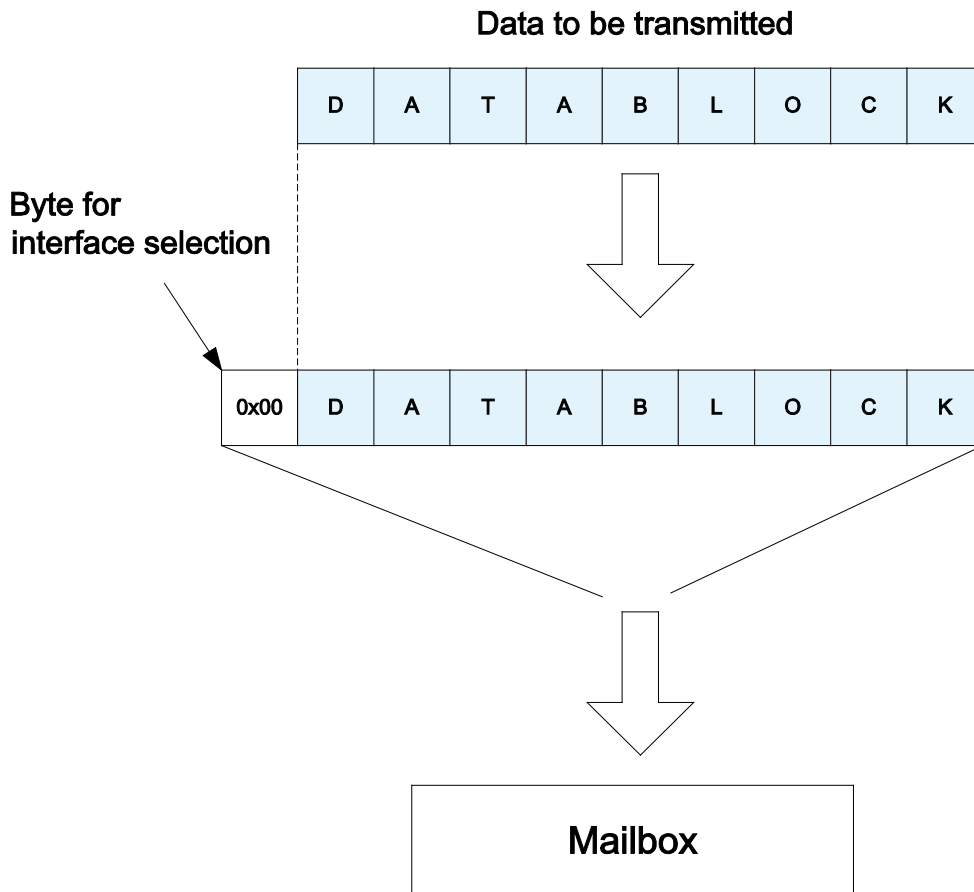

Figure 21: Example of message processing

### 9.3.2 Flow Control

For a configuration as an RS-232 interface, there is the option of hardware flow control via RTS/CTS. Alternatively, flow control via XOn/XOff can be activated. Once flow control has been selected, the module takes over generation of the required signals on the interface.

The status of the CTS line is transferred to the control unit in the status byte (see input process image) for possible evaluation. For flow control via XOn/XOff, the CTS/XOff bit is set once an XOff tag has been received.

The RTS line of the interface can be controlled via the control byte (see output process image) independent of the module software. For flow control via XOn/XOff, setting the RTS bit causes the XOff to be sent. When the RTS bit is reset by the control unit, XOn is sent. It should be noted that the module software controls the RTS function independent of the control unit as soon as the level of the internal buffer requires it.

### 9.3.3 Control of Internal Buffers

The fill level of internal buffers appears in the status byte of the respective interface (see input process image).

- Bit 1 is set once the output buffer is full and the module cannot accept any data from the control unit.
- Bit 2 is set once the reception buffer is full and the module can no longer take any data from the external device.
- Bit 4 is set if the output buffer is empty, i.e. all data has been output via the interface.

If the reception buffer is full, the module generates the required control signals for the externally connected device when flow control has been activated for the interface.

The internal buffer can be cleared as required. To do so, proceed as follows:

1. Setting of bit 1 (buffer reset) in the control byte of the respective interface by the control unit.
2. The module responds after the buffer has been successfully cleared by setting bit 3 (confirmation of buffer reset) in the status byte.
3. Cancellation of bit 1 (buffer reset) in the control byte of the respective interface.
4. The module cancels bit 3 (buffer reset confirmation).

## 10 Diagnostics

### 10.1 LED Signaling

The following table lists the operating messages that are indicated via LEDs. Information regarding remedies of certain causes is also provided.

#### Note



##### Disabling specific diagnostics

Use the diagnostic overview (section "Parameterizing" > "Diagnostic Overview") to disable specific diagnostics (see F- and I/O-LED). In this case, the corresponding LED is disabled (off).

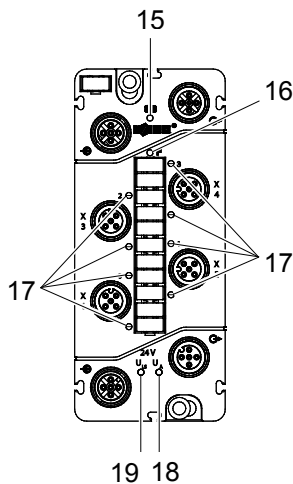

Figure 22: LEDs indicating operational messages (exemplary)

Table 43: Operating messages 1

Pos.	LED	Color/Status	Cause	Remedy/information
15	SB	Off	Low voltage; $U_{LS}$ not available.	Check the power supply.
		Red, flashing, 4 Hz	S-BUS error on module.	Check whether the S-BUS cable is connected. Check the S-BUS cable for damages. Check whether the fieldbus coupler firmware is compatible with the module.
		Red, flashing, 1 or 2 Hz	The module is being restarted via the fieldbus coupler.	If the flashing frequency is 1Hz, please contact WAGO Support.
		Green	Data exchange is in process; process data values are valid. The module is in RUN mode.	-

Table 43: Operating messages 1

Pos.	LED	Color/Status	Cause	Remedy/information
15	SB	Green and orange, flashing, 1 Hz	The set substitute value is applied to the module.	Can be set by the fieldbus coupler if fieldbus is missing. Check the fieldbus connection and the status of the higher-level controller.
		Orange, flashing, 2 Hz	The module has detected the S-BUS.	-
		Orange and green, flashing, 4 Hz	The last module is being detected in the 767 node.	Check the S-BUS terminator and/or the S-BUS cables.
		Orange, flashing, 1 Hz	The fieldbus coupler is addressing the module in the 767 node.	-
		Orange and green, flashing, 2 Hz	The S-BUS parameters are being stored by the fieldbus coupler.	-
		Orange	The firmware is being updated.	All 767 Series components are being updated by the fieldbus coupler within the node.
		Orange, flashing, 4 Hz	The module is attempting to establish communication with the fieldbus coupler.	Check the power supply to upstream 767 Series component and/or check the S-BUS cable for damages.
15	SB	Green, flashing, 1 Hz	The module is in HOLD mode.	Is initiated by the fieldbus coupler. In DI mode, the last input values transferred to the fieldbus coupler are kept in the process image. In DO mode, the last output values are retained.
		Green, flashing, 2 Hz	The module is in STOP mode.	Is initiated by the fieldbus coupler. In DI mode, the input values are set to 0 in the process image. In DO mode, the output value is output as 0.

Table 44: Operational messages 2

No.	LED	Color/status	Cause	Remedy/information
16	F	Red	There is at least one global diagnostic message on the module.	Check the supply voltages $U_{LS}$ and $U_A$ of the upstream 767 Series components. For more information, see the section "Parameterizing">"Diagnostic Overview"
17	Ch 1.1 Ch 2.1	Off	No data to send	Check the connection of the external device and that the transmission parameters match.
		Yellow flashing	Channel sends data	-
		Yellow static	Channel is waiting for readiness to receive from the end device (XOn or CTS).	Check the connection of the external device and that the transmission parameters match.
	Ch 1.2 Ch 2.2	Off	No data receipt	Check the connection of the external device and that the transmission parameters match.
		Yellow flashing	Channel receives data	-
		Yellow static	Channel reported XOff or CTS reset.	Check the connection of the external device and that the transmission parameters match.
		Red	Faulty data received or buffer overflow.	Check the connection of the external device and that the transmission parameters match.

Table 44: Operational messages 2

No.	LED	Color/status	Cause	Remedy/information
17	0 ... 3	Yellow	Input: Signal active and is recognized as '1'.	-
			Output: Output signal is active.	Check the actuator connection for short circuit/overload. A short circuit or overload can only occur when the output is switched on.
		Red*	Error on output	Check the actuator connection for short circuit/overload.
* If you set the time of the parameter "Restart delay, actuator" (section "Parameterizing"> "Output Parameters") to 0 ms, the I/O LED appears yellow rather than red in case of a short circuit or overload due to the short restart interval.				
18	U <sub>A</sub>	Green	Actuator supply U <sub>A</sub> is present.	-
		Off	Actuator supply U <sub>A</sub> is not present.	Connect the power supply and check the voltage level, if applicable.
19	U <sub>LS</sub>	Green	Logic supply and sensor supply U <sub>LS</sub> are present.	-
		Off	Logic supply and sensor supply U <sub>LS</sub> are not present.	Connect the power supply and check the voltage level, if applicable.

## 11 Service

This section contains information on maintenance and service.

### 11.1 Updating the Firmware

The firmware for the module can be updated. This takes place via the USB connection of a fieldbus coupler. Additional information can be found in the fieldbus manuals in section "Updating the Firmware".

### 11.2 Replacing the Module

To replace a module, e.g., to change variants, proceed as described follow.

#### 11.2.1 Disconnecting the Cables

Before removing the connectors, clean the module to ensure that no dirt or other material comes in contact with the connections. This can lead to damage of the contacts.

To unplug the cables, proceed as follows:

1. Disconnect the power supply from those devices on which you have mounted the module.



#### CAUTION

##### **Hot connection sockets!**

Even when taking into account derating, high surface temperatures on the metallic connection sockets and on the enclosure can arise during operation. If the 767 Series component has been in operation, allow it to cool off before moving it.

2. Unscrew all screw connections and remove the cables.

## 11.2.2 Removing the Module from Your System

To remove the module from your system's framework, proceed as follows:

1. Disconnect the power supply from those devices on which you have mounted the module.
2. Release the module from your system by unscrewing the M4 screws.

## 11.2.3 Removing the Module from the Carrier Rail

In order to keep the representation unambiguous, the carrier rail adapter in the following figure (B, C) is shown without module.

If the module is mounted on a carrier rail, proceed with the removal as follows:

1. Disconnect the power supply from those devices on which you have mounted the module.
2. To remove the module, press down the release actuator of the carrier rail adapter using a slot screwdriver (B) and remove it from the carrier rail (C).

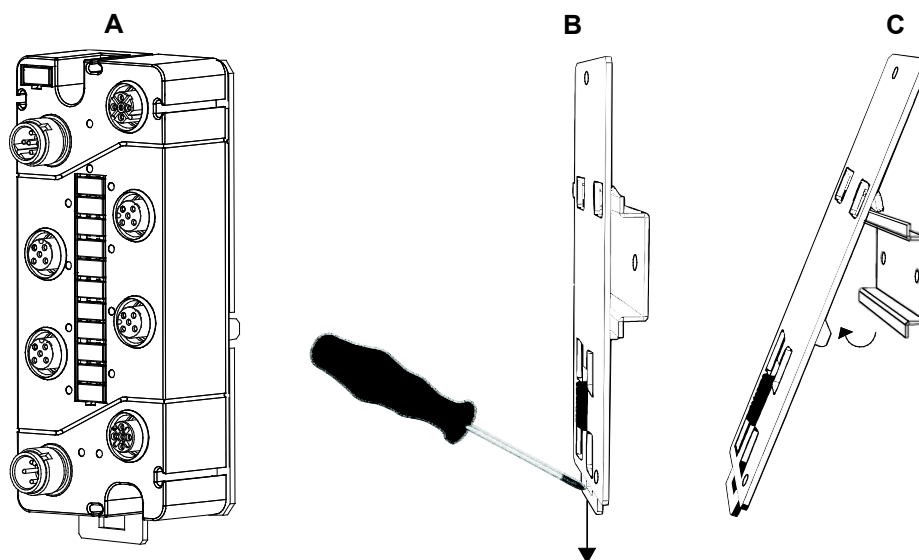

Figure 23: Removing the module (with the carrier rail adapter) from the carrier rail

### 11.2.4 Removing the Module from the Profile Adapter

If the module is mounted on a profile adapter, proceed with the removal as follows:

1. Disconnect the power supply from that part of the system on which you have mounted the module before attempting to remove it.
2. Unscrew the screws on which the nuts are fastened and remove the module from the profile rail of your system.
3. Unscrew the screws that connect the module with the profile adapter.

### 11.2.5 Connecting the Module

To connect the module, proceed as described in Sections 4 through 6. If necessary, the parameters of the previous module are transferred to the new module, depending on the type of fieldbus coupler being used. For more information, see section "Parameterizing" > "Automatic Storage of System Parameters".

## 11.3 Disposal

Do not dispose of the 767 Series components in the household waste; observe the laws which apply to them. You can also contact a certified waste management company.

## 12 Appendix

### 12.1 Diagnostic Information

Some fieldbus couplers display the error code in the form of an attribute path (CIA), through which diagnostics are clearly assigned. Other fieldbus couplers (e.g., PROFINET I/O or PROFIBUS DP) convert the attribute path into a fieldbus-specific message.

The following diagnostic codes can be generated by the module:

Table 45: Diagnostics of the module

Diagnostic Message	Attribute Path			Classification
	C	I	A	
Short circuit/overload of field supply The function is only enabled when the field supply is switched on.	16	1	128	Diagnostic alarm
Low voltage $U_{LS}$ (sensor supply)	50	1	128	Diagnostic alarm
Low voltage $U_A$ (actuator supply)	50	1	129	Diagnostic alarm

Table 46: Diagnostics of the individual channels of the module

Diagnostic Message	Attribute Path			Classification
	C	I	A	
Overtemperature This function is only enabled when the actuator output is switched on.	9	Chanel (1 - 4)	130	Diagnostic alarm

Use the diagnostics overview of the section of the same name to disable specific diagnostics.

## 12.2 Mailbox 2.0 Transmission Method

Mailbox 2.0 defines a service to transfer data full-duplex via a defined channel.

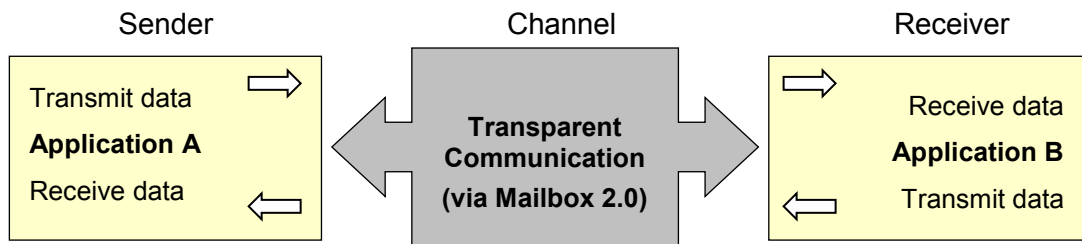

Figure 24: Communication via Mailbox 2.0

### Example:

A sender wants to transfer 10 bytes (the character string "Hello Wago") to a receiver via a 4-byte wide channel.

### 12.2.1 Message

The Mailbox 2.0 method packages the data in messages. A message contains a header and user data.

There are two message types.

Message with simple header:

xx	"H"	"a"	"I"	"I"	"o"	" "	"W"	"a"	"g"	"o"
----	-----	-----	-----	-----	-----	-----	-----	-----	-----	-----

Message with extended header:

xx	xx	xx	"H"	"a"	"I"	"I"	"o"	" "	"W"	"a"	"g"	"o"
----	----	----	-----	-----	-----	-----	-----	-----	-----	-----	-----	-----

Structure of the simple header:

Table 47: Structure of the Simple Header

Simple header							
Bit 7	Bit 6	Bit 5	Bit 4	Bit 3	Bit 2	Bit 1	Bit 0
0	Length						

Data element length max. 127 bytes  
0: Simple header

Structure of the extended header:

Table 48: Structure of the Extended Header

Extended header				
Bit 7	Bit 6	Bit 5 ... 0	Bit 7 ... 0	Bit 7 ... 0
1	0	Length High	Length Low	Protocol ID

Procoll\_ID 0..255  
Data element length max. 16383 bytes  
10: Extended header

A message that uses this header can contain 16383 bytes of user data. In addition, the message can have a protocol ID. This protocol ID allows the message to include a logical meaning.

## 12.2.2 Transmission Channel

To transfer a message over a narrow channel, synchronization between sender and receiver is required. Therefore, the transmission channel is divided into a synchronization part and a data part.

For synchronization, a so-called handshake byte (HB) is defined.

The handshake byte occupies the first byte of the transmission channel while part of the message is always delivered in the remaining bytes.

HB	Part of the message
----	---------------------

There is always one transmission channel from the sender to the receiver and one transmission channel from the receiver to the sender. Both channels do not have to be the same size. However, the minimum size is 1 byte.

### 12.2.2.1 The Handshake Byte

In general, a distinction is made between Control(C) and Toggle(T) mode (bit 7). The Control mode is used to synchronize the subscribers. The Toggle mode is used to exchange data.

Structure of the handshake byte:

Table 49: Structure of the Handshake Byte

Handshake byte							
Bit 7	Bit 6	Bit 5	Bit 4	Bit 3	Bit 2	Bit 1	Bit 0
Status				Control			
C/T	Response			C/T	Command		
	T	0x0			T	0x0	

The following figure shows the basic use of the handshake byte.

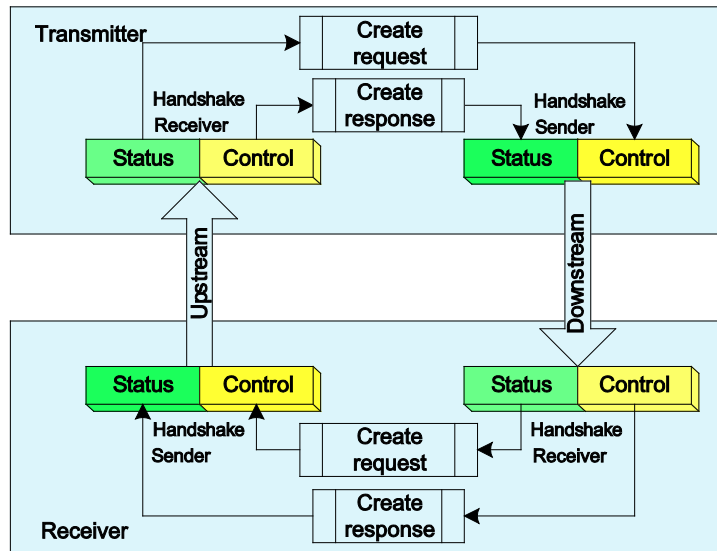

Figure 25: Use of the Handshake Byte

## 12.2.3 Communication Phases

The Mailbox 2.0 mechanism defines two communication phases:

- Synchronization
- Data exchange

Only after successful synchronization from sender to receiver the actual user data can be exchanged.

### 12.2.3.1 Synchronization

In the synchronization phase, the handshake byte is used in Control mode.

A distinction is made between interpretation as signaling mode and interpretation as command acknowledgement mode.

In command acknowledgement mode, the handshake byte appears as follows:

Status Nibble				Control Nibble			
Bit 3	Bit 2	Bit 1	Bit 0	Bit 3	Bit 2	Bit 1	Bit 0
0	Acknowledgement			0	Acknowledgement		

The Control nibble is used to transfer a request while the Status nibble contains the response to the request.

#### 12.2.3.1.1 Mailbox Commands

The following commands are defined:

Table 50: Commands

Value	Explanation	Description
0	INVALID	Signals that the sender has not started operations again after a reset.
1	HOLD REQUEST	Notice that the channel is ready, but data is not currently being transferred (e.g. because the output buffer is still empty)
2	RESET REQUEST	Prompt to reset
3 ... 7	-	(not supported, ignore)

### 12.2.3.1.2 Acknowledgement

The following acknowledgements are defined:

Table 51: Acknowledgement

Value	Explanation	Description
0	INVALID	Signals that the receiver has not started operations again after a reset.
1	HOLD ACKNOWLEDGE	Signal or confirmation that the channel is ready, but data is not currently being transferred (e.g. because there is not any data yet).
2	RESET ACKNOWLEDGE	Response to "RESET REQUEST" when Mailbox in reset.
3 ... 7	-	(not supported, ignore)

### 12.2.3.1.3 Signaling

In signal mode, the handshake byte appears as follows:

Table 52: Structure of the Handshake Byte

Handshake byte							
Bit 7	Bit 6	Bit 5	Bit 4	Bit 3	Bit 2	Bit 1	Bit 0
0	0	Signal					

Table 53: Signaling

Value	Explanation	Description
0x00	INVALID SIGNAL	State of the process image with no effect by Mailbox 2.0
0x32	RESET SIGNAL	Shows that the local Mailbox is in the process of restarting
0x33	ERROR SIGNAL	Shows that the local Mailbox is in the fault condition
(other)	-	Other values are not considered as signals and are processed separately in the Status or Control nibble.

### 12.2.3.1.4 Finite Automation

Synchronization follows the chart below.

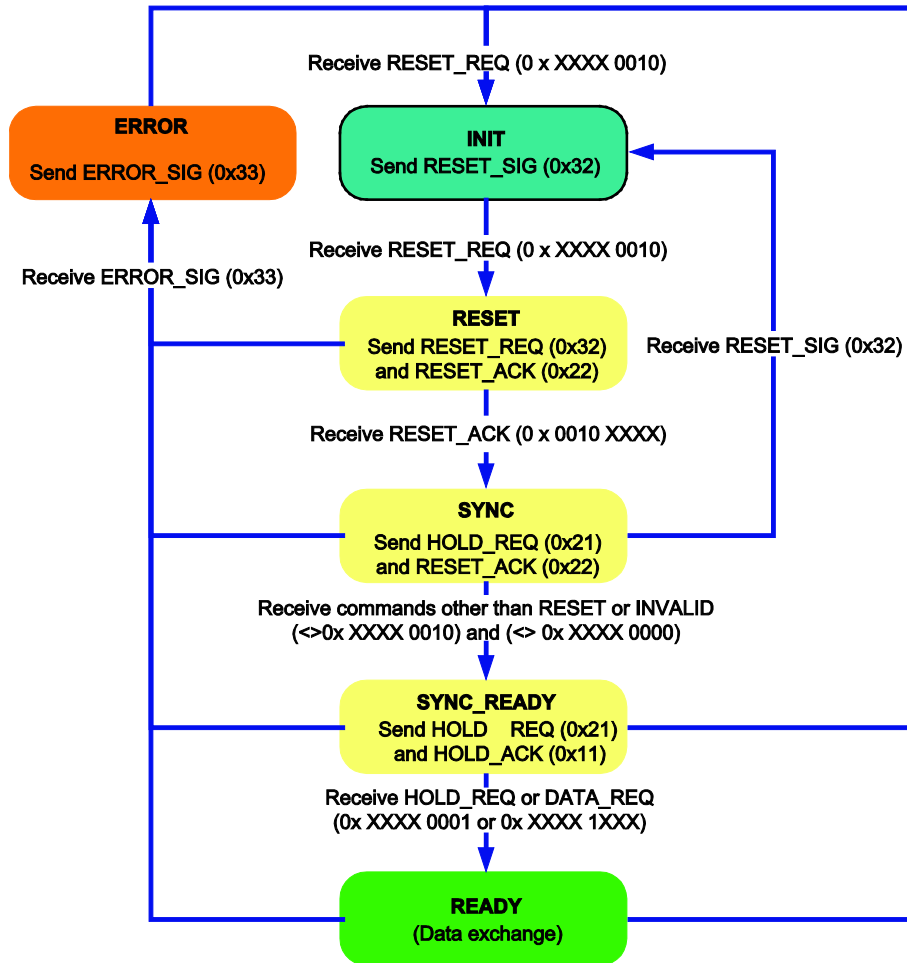

Figure 26: Finite Automation

### 12.2.3.2 Data Exchange

In the data exchange phase, the handshake byte is used in Toggle mode. Because a message is normally larger than the data part of the transmission channel, the message must be transferred in several cycles (fragmentation).

Status Nibble			
Bit 3	Bit 2	Bit 1	Bit 0
1	T	0x00	

Control Nibble			
Bit 3	Bit 2	Bit 1	Bit 0
1	T	0x00	

#### Send fragment:

The first toggle bit expected by the receiver after synchronization has the value 0. The toggle bit in the second fragment receives a 1, the toggle bit in the third fragment again a 0, etc. Only when the status of the toggle bit matches in the received status nibble is receipt of the fragment confirmed by the receiver. Only then can a new fragment be sent. As long as there is no confirmation, the fragment remains unchanged in the process image.

For the special case that the content of the send buffer is no longer sufficient to fill the transmission channel completely, the transmission channel is filled with zeros to the end.

#### Receive fragment:

The control now has to confirm receipt of this fragment. Receipt is confirmed by inverting the toggle bit of the status nibble to be sent.

Because the Mailbox 2.0 mechanism is full-duplex capable, data can be sent and received at the same time.



## List of Figures

Figure 1: Connectors (exemplary).....	17
Figure 2: Marking possibilities and fastening (exemplary).....	18
Figure 3: Display elements (exemplary) .....	19
Figure 4: Labeling .....	20
Figure 5: Label on the module .....	21
Figure 6: Schematic diagram.....	22
Figure 7: Dimensions of the module in millimeters (exemplary) .....	23
Figure 8: Mounting the module on a grounded frame or to another grounding point .....	34
Figure 9: Fastening to the carrier rail adapter .....	35
Figure 10: Mounting the carrier rail adapter (exemplary).....	36
Figure 11: Fastening to the profile adapter .....	37
Figure 12: Replacing the marking spaces.....	39
Figure 13: Attaching a spacer to a module.....	40
Figure 14: Attaching another module with a spacer.....	41
Figure 15: S-BUS connected to a fieldbus coupler and modules.....	45
Figure 16: Supply cable connected to a fieldbus coupler and modules .....	47
Figure 17: Connectors of interfaces .....	49
Figure 18: Connectors of sensors/actuators.....	51
Figure 19: Example of an open DTM, including parameters.....	54
Figure 20: Example of the diagnostic overview of a module (information may differ from the actual module).....	56
Figure 21: Example of message processing .....	73
Figure 22: LEDs indicating operational messages (exemplary) .....	76
Figure 23: Removing the module (with the carrier rail adapter) from the carrier rail .....	81
Figure 24: Communication via Mailbox 2.0 .....	84
Figure 25: Use of the Handshake Byte.....	86
Figure 26: Finite Automation .....	89
Figure 27: Example of Send Operation.....	91

## List of Tables

Table 1: Number Notation.....	9
Table 2: Font Conventions .....	9
Table 3: Legend for figure "Connectors" .....	17
Table 4: Legend for figure "Marking possibilities and fastening" .....	18
Table 5: Legend for figure "Display elements" .....	19
Table 6: Legend for figure "Labeling" .....	20
Table 7: Description of manufacturing number .....	21
Table 8: Technical data – Device.....	24
Table 9: Technical data – Supply.....	24
Table 10: Technical data – Communication .....	24
Table 11: Technical data – Serial interfaces .....	25
Table 12: Technical data – Digital inputs .....	25
Table 13: Technical data – Input characteristic .....	25
Table 14: Technical data – Digital outputs .....	26
Table 15: Technical data – Actuator selection.....	26
Table 16: Technical data – Operating states .....	27
Table 17: Technical data – Configurable functions of the serial interfaces .....	27
Table 18: Technical data – Configurable functions of the digital inputs/outputs .....	27
Table 19: Technical data – Diagnostics .....	27
Table 20: Technical data – Process image .....	28
Table 21: Technical data – Indicators .....	28
Table 22: Technical data – Isolation .....	28
Table 23: S-BUS connection assignment.....	44
Table 24: Supply connection assignment.....	46
Table 25: Serial interfaces: Pin assignment .....	48
Table 26: Digital inputs and outputs: Pin assignment.....	50
Table 27: DTM buttons .....	54
Table 28: Information on the module.....	55
Table 29: Diagnostics setup .....	56
Table 30: Information about existing module diagnostics.....	57
Table 31: Information about existing channel diagnostics.....	57
Table 32: Overview of the connection mode .....	58
Table 33: Overview of adjustable parameters for the digital outputs .....	59
Table 34: Overview of adjustable parameters for the digital inputs .....	61
Table 35: Parameters of the serial interfaces.....	62
Table 36: Input buffer, serial interface.....	64
Table 37: Output buffer, serial interface .....	65
Table 38: Overview of parameters for the entire module .....	66
Table 39: Overview of adjustable parameters for the field supply .....	66
Table 40: Input data in the process image.....	69
Table 41: Output data in the process image .....	70
Table 42: Selection byte for the interface .....	73
Table 43: Operating messages 1 .....	76
Table 44: Operational messages 2.....	78
Table 45: Diagnostics of the module.....	83
Table 46: Diagnostics of the individual channels of the module .....	83

---

Table 47: Structure of the Simple Header .....	85
Table 48: Structure of the Extended Header .....	85
Table 49: Structure of the Handshake Byte.....	86
Table 50: Commands.....	87
Table 51: Acknowledgement.....	88
Table 52: Structure of the Handshake Byte.....	88
Table 53: Signaling .....	88



# WE! INNOVATE!

WAGO Kontakttechnik GmbH & Co. KG  
Postfach 2880 • D-32385 Minden  
Hansastraße 27 • D-32423 Minden  
Phone: 05 71/8 87 – 0  
Fax: 05 71/8 87 – 1 69  
E-Mail: [info@wago.com](mailto:info@wago.com)  
Internet: <http://www.wago.com>

