

WAGO-SPEEDWAY 767

Manual



767-5803/000-800
8DIO 24V DC 0.5A IF (8xM12)
Digital Input/Output Module 24 V DC / 0.5 A

Version 1.1.0

© 2016 by WAGO Kontakttechnik GmbH & Co. KG
All rights reserved.

WAGO Kontakttechnik GmbH & Co. KG

Hansastraße 27
D-32423 Minden

Phone: +49 (0) 571/8 87 – 0
Fax: +49 (0) 571/8 87 – 1 69

E-Mail: info@wago.com

Web: <http://www.wago.com>

Technical Support

Phone: +49 (0) 571/8 87 – 5 55
Fax: +49 (0) 571/8 87 – 85 55

E-Mail: support@wago.com

Every conceivable measure has been taken to ensure the accuracy and completeness of this documentation. However, as errors can never be fully excluded, we always appreciate any information or suggestions for improving the documentation.

E-Mail: documentation@wago.com

We wish to point out that the software and hardware terms as well as the trademarks of companies used and/or mentioned in the present manual are generally protected by trademark or patent.

Table of Contents

1	Notes about this Documentation.....	6
1.1	Validity of these Operating Instructions	6
1.2	Copyright.....	6
1.3	Symbols.....	7
1.4	Number Notation.....	9
1.5	Font Conventions	9
2	Important Notes	10
2.1	Legal Bases	10
2.1.1	Subject to Changes	10
2.1.2	Personnel Qualification	10
2.1.3	Use in Compliance with Underlying Provisions	11
2.1.4	Technical Condition of Specified Devices	12
2.2	Safety Advice (Precautions).....	13
2.3	Safety Equipment	14
2.4	Notes on Operation	15
3	Device Description	16
3.1	Connectors.....	17
3.2	Marking Possibilities and Fastening	18
3.3	Display Elements	19
3.4	Labeling.....	20
3.5	Schematic Diagram	22
3.6	Dimensions.....	23
3.7	Technical Data	24
3.7.1	General Information	24
3.7.2	Supply.....	24
3.7.3	Communication	24
3.7.4	Inputs	25
3.7.5	Input Characteristic	26
3.7.6	Outputs	26
3.7.7	Information on actuator selection.....	27
3.7.8	Operating state influence on output.....	27
3.7.9	Counter 1 and 2 (configurable).....	28
3.7.10	Configurable Functions	28
3.7.11	Configurable functions for counters.....	29
3.7.12	Diagnostics	30
3.7.13	Process Image.....	30
3.7.14	Indicators	30
3.7.15	Isolation	30
3.8	Approvals	31
3.9	Standards and Guidelines	32
4	Mounting.....	33
4.1	Information on Mounting.....	33
4.2	Tools and Accessories Required for Mounting.....	35
4.3	Direct Mounting on Your System	36
4.4	Mounting on a Carrier Rail (only with WAGO Accessories).....	37

4.4.1	Fastening the Carrier Rail Adapter to the Module	37
4.4.2	Fastening the Module with Carrier Rail Adapter to a Carrier Rail	38
4.5	Mounting on a Profile Rail (only with WAGO Accessories)	39
4.5.1	Fastening the Profile Adapter to the Module	39
4.5.2	Fastening the Module with Profile Adapter to a Profile Rail	40
4.6	Marking and Replacing the Marking Spaces	41
4.7	Mounting the Spacer in the Case of Compact Arrangement.....	42
5	Connecting Data and Supply Cables.....	44
5.1	Notes	44
5.2	Required Accessories	45
5.3	Connecting the S-BUS Cables	46
5.4	Connecting the Supply Cable.....	48
5.5	Connect Sensor/Actuator Cable	50
6	Commissioning	52
7	Parameterizing	53
7.1	Electronic Type Label	55
7.2	Diagnostic Overview	56
7.2.1	Input and Output Parameters	58
7.2.2	"DO Module" Mode	59
7.2.3	"DI Module" Mode	61
7.2.4	"DIO Module" Mode	61
7.2.5	"DIO Module with Counter" Mode	62
7.3	Global Settings	64
7.4	Parameters of Field Supply	64
7.5	Automatic Storage of System Parameters.....	65
7.6	Updating the Firmware	65
8	Process Image	66
8.1	DO Mode.....	68
8.1.1	Input Data	68
8.1.2	Output Data	69
8.2	DI Mode	70
8.2.1	Input Data	70
8.2.2	Output Data	71
8.3	DIO Mode	72
8.3.1	Input Data	72
8.3.2	Output Data	73
8.4	DIO Mode + 1 Counter	74
8.4.1	Input Data	74
8.4.2	Output Data	75
8.5	DIO Mode + 2 Counters.....	77
8.5.1	Input Data	77
8.5.2	Output Data	78
9	Counter Function	80
9.1	Control of the Counter via Inputs and Outputs	81
9.2	Controlling and Monitoring of the Counter via the Process Data.....	82
9.2.1	Control Byte	82
9.2.2	Status Byte.....	83

9.2.3	Example of Controlling Two Counters via the Process Data.....	84
10	Diagnostics	85
10.1	LED Signaling.....	85
11	Service	88
11.1	Updating the Firmware	88
11.2	Replacing the Module	88
11.2.1	Disconnecting the Cables	88
11.2.2	Removing the Module from Your System	89
11.2.3	Removing the Module from the Carrier Rail	89
11.2.4	Removing the Module from the Profile Adapter.....	90
11.2.5	Connecting the Module	90
11.3	Disposal.....	90
12	Use of the Interference-Free Module in Safety Applications.....	91
12.1	Important Notes.....	91
12.2	General Measures and Conditions for the Power Supply Solution of the Module.....	92
12.3	Measures and Conditions for Shielded Power Supply of the Module	94
12.4	Measures and Conditions for Unshielded Power Supply of the Module	95
12.5	Connection of the Module to Safety Switching Devices	96
12.5.1	General Structure of a Potential Group	96
12.5.2	Examples of Connection.....	97
13	Appendix.....	98
13.1	Diagnostic Information	98
	List of Figures	99
	List of Tables.....	100

1 Notes about this Documentation

The module shall only be installed and operated in conjunction with these operating instructions and the system description.

WARNING

Observe release notes!

Please note that, within the SPEEDWAY system, a function is provided **without restriction** only if all system's components have the same system-wide firmware release. Therefore, always observe the appropriate release notes on products used.

NOTICE

Supply layout!

In addition to these operating instructions, you will need the “WAGO *SPEEDWAY 767*, System Description and Information” manual, which can be downloaded at www.wago.com. There you will find information regarding supply layout, etc.

Note



Always retain this documentation!

This documentation is part of the product. Therefore, retain the documentation during the entire service life of the product. Pass on the documentation to any subsequent user. In addition, ensure that any supplement to this documentation is included, if necessary.

1.1 Validity of these Operating Instructions

These operating instructions are only applicable to the WAGO *SPEEDWAY 767* Series module 8DIO 24V DC 0.5A IF (8xM12), 767-5803/000-800.

1.2 Copyright

This Manual, including all figures and illustrations, is copyright-protected. Any further use of this Manual by third parties that violate pertinent copyright provisions is prohibited. Reproduction, translation, electronic and phototechnical filing/archiving (e.g., photocopying) as well as any amendments require the written consent of WAGO Kontakttechnik GmbH & Co. KG, Minden, Germany. Non-observance will involve the right to assert damage claims.

1.3 Symbols

 **DANGER**

Personal Injury!

Indicates a high-risk, imminently hazardous situation which, if not avoided, will result in death or serious injury.

 **DANGER**

Personal Injury Caused by Electric Current!

Indicates a high-risk, imminently hazardous situation which, if not avoided, will result in death or serious injury.

 **WARNING**

Personal Injury!

Indicates a moderate-risk, potentially hazardous situation which, if not avoided, could result in death or serious injury.

 **CAUTION**

Personal Injury!

Indicates a low-risk, potentially hazardous situation which, if not avoided, may result in minor or moderate injury.

NOTICE

Damage to Property!

Indicates a potentially hazardous situation which, if not avoided, may result in damage to property.

NOTICE

Damage to Property Caused by Electrostatic Discharge (ESD)!

Indicates a potentially hazardous situation which, if not avoided, may result in damage to property.

Note

Important Note!

Indicates a potential malfunction which, if not avoided, however, will not result in damage to property.

Information



Additional Information:

Refers to additional information which is not an integral part of this documentation (e.g., the Internet).

1.4 Number Notation

Table 1: Number Notation

Number Code	Example	Note
Decimal	100	Normal notation
Hexadecimal	0x64	C notation
Binary	'100' '0110.0100'	In quotation marks, nibble separated with dots (.)

1.5 Font Conventions

Table 2: Font Conventions

Font Type	Indicates
<i>italic</i>	Names of paths and data files are marked in italic-type. e.g.: <i>C:\Program Files\WAGO Software</i>
Menu	Menu items are marked in bold letters. e.g.: Save
>	A greater-than sign between two names means the selection of a menu item from a menu. e.g.: File > New
Input	Designation of input or optional fields are marked in bold letters, e.g.: Start of measurement range
“Value”	Input or selective values are marked in inverted commas. e.g.: Enter the value “4 mA” under Start of measurement range .
[Button]	Pushbuttons in dialog boxes are marked with bold letters in square brackets. e.g.: [Input]
[Key]	Keys are marked with bold letters in square brackets. e.g.: [F5]

2 Important Notes

This section includes an overall summary of the most important safety requirements and notes that are mentioned in each individual section. To protect your health and prevent damage to devices as well, it is imperative to read and carefully follow the safety guidelines.

2.1 Legal Bases

2.1.1 Subject to Changes

WAGO Kontakttechnik GmbH & Co. KG reserves the right to provide for any alterations or modifications that serve to increase the efficiency of technical progress. WAGO Kontakttechnik GmbH & Co. KG owns all rights arising from the granting of patents or from the legal protection of utility patents. Third-party products are always mentioned without any reference to patent rights. Thus, the existence of such rights cannot be excluded.

2.1.2 Personnel Qualification

All sequences implemented on the module may only be carried out by electrical specialists with sufficient knowledge in automation. The specialists must be familiar with the current standards and guidelines for the module and automation environment.

2.1.3 Use in Compliance with Underlying Provisions

The 767-5803/000-800 module is used to output digital signals that are transmitted by a higher-level controller (such as a programmable fieldbus coupler) and/or for the recording of digital field signals such as those from sensors.

The module may not be used to control safety-related functions, i.e. it cannot be a functional part of a safety function.

The digital outputs of the module are interference-free to eliminate any impact by the internal potential groups.

In a safety circuit, the module shall only be used together with a safety switching device (with diagnostic function).

If additional modules are required, these modules must also be interference-free. The module itself is no safety-oriented module. Note the "Use of the Interference-Free Module in Safety Applications" chapter.

The module may only be operated in combination with components of the WAGO *SPEEDWAY* 767 Series.

The module was developed for applications requiring IP 67 (NEMA type 6, 6P) protection.

Applications other than those described in this manual are not permitted.

2.1.4 Technical Condition of Specified Devices

The devices to be supplied ex works are equipped with hardware and software configurations, which meet the individual application requirements. WAGO Kontakttechnik GmbH & Co. KG will be exempted from any liability in case of changes in hardware or software as well as to non-compliant usage of devices.

Please send your request for modified and new hardware or software configurations directly to WAGO Kontakttechnik GmbH & Co. KG.

2.2 Safety Advice (Precautions)

DANGER



Electric voltage!

Operate the 767 Series components exclusively with 24 VDC PELV (Protective Extra Low Voltage) or SELV (Safety Extra Low Voltage) voltage sources. Failure to comply may result in electric shock.

CAUTION



Hot connection sockets!

Even when taking into account derating, high surface temperatures on the metallic connection sockets and on the enclosure can arise during operation. If the 767 Series component has been in operation, allow it to cool off before moving it.

NOTICE

The highest current carrying capacity of the supply contacts is 4 A!

Always observe the maximum current carrying capacity per supply line (U_{LS} , U_A) for each 767 Series component and the overall power consumption for all 767 components. Neither of these values shall exceed 4 A since an increase in current causes the contacts to overheat and damages the 767 Series components. Information regarding the power demand of each 767 Series component can be found in the corresponding data sheet, which is available from www.wago.com.

NOTICE

Exposed connections!

If connections have not been closed with protective caps, liquid or dirt can penetrate the components of the 767 Series module and ruin it. Therefore, close all unnecessary connections with protective caps, which must be ordered separately, in order to maintain the IP67 degree of protection. (See section “Accessories” of the fieldbus coupler/controller manual.)

- Disconnect the power supply from the system on which you wish to mount the 767 Series device.
- Observe the appropriate accident prevention regulations for your system during assembly, start-up, maintenance, and repairs. For example, BGV A3, “Electrical systems and equipment”.
- The operating instructions for the 767 Series module and the system description must be laid out ready on site.
- Observe the exact positioning (coding) between plug and socket.
- The 767 Series device shall not come into contact with substances having seeping and insulating properties. Otherwise, additional measures shall be

taken for the device, such as installation of an enclosure that is resistant to the above-mentioned substance properties.

- Electronic components fulfilling the ESD requirements according to the IEC 61000-6-2 are integrated in the 767 device. As higher voltages may occur, under unfavorable circumstances, due to electrical charge in the field, discharge must be ensured before performing work on the 767 system.
- Ensure that the potential equalization is correctly laid out.
- Keep all cables a sufficient distance away from electromagnetic sources of interference in order to maintain a high level of interference resistance of the 767 system against electromagnetic emissions. Use only shielded cables at the necessary locations, and always observe the appropriate standards for EMC-suitable installations.
- For the power supply and for the S-BUS, use only pre-assembled WAGO system cables, so the specified characteristics of the technical data can be achieved.
- Replace defective or damaged modules (e.g., deformed connections), else function disruptions can occur in the respective fieldbus stations or nodes.
- When laying any cables, make sure that you do not lay them within the shear range of movable machine parts.
- For each activity, observe the corresponding personnel qualification in the corresponding section.
- Observe the marking on the front and rear side of the module.

2.3 Safety Equipment

All 767 Series products are designed to meet the requirements of IP67. This includes complete protection against accidental contact with electrical voltage and currents – even when wet.

2.4 Notes on Operation

When integrating the 767 module in your machine or system, all the currently applicable norms, regulations and guidelines shall be observed during all activities: for example, BGV A3, “Electrical systems and equipment”, DIN EN 418, EN 60204. The emergency stop equipment shall remain effective in all operating modes of the system and machine.

For protection from electromagnetic interferences

- Connect your system to protective earth (PE), and
- Ensure that the cable routing and the installation of the fieldbus cable, S-BUS cable, supply cable, and sensor or actuator cable are correct.

The following elements for 24 V supply shall be present:

- Outer lightning protection on buildings
- Inner lightning protection of supply lines and signal lines
- Safe electrical separation of low voltage 24 VDC through PELV (Protective Extra Low Voltage) or SELV (Safety Extra Low Voltage) voltage sources

3 Device Description

The module 767-5803/000-800 is a hybrid module, which can be operated in five ways:

- **DO mode**
Operating as a digital output module (all channels)
This mode is used, for example, to control solenoid valves, contactors, encoders, relays or other elect. loads.
- **DI mode**
Operation as digital input module (all channels)
This mode is used, for example, to evaluate encoders, sensors, switches and proximity switches.
- **DIO mode** (*Delivery state*)
Combined operation of digital inputs and outputs (parametrizable per channel).
This mode combines inputs and outputs on one module. By default, all channels are configured as digital inputs.
- **DIO mode + 1 counter**
Combined operation of digital inputs and outputs with a counter function. The counter can be configured as an event counter, gate time counter or pulse duration counter.
- **DIO mode + 2 counters**
Combined operation of digital inputs and outputs with two counter functions. The counter can be configured as an event counter, gate time counter or pulse duration counter.

The module has many configuration options that can be carried out via a fieldbus coupler. The module settings take on fieldbus through the device description file (eg. GSD, GSDML, etc.) of a field bus or via FDT / DTM frame application (eg. WAGOframe). Detailed information about assignment of module parameters using a fieldbus in the corresponding manual (e.g., PROFIBUS Fieldbus Coupler 767-1101).

Detailed information about the properties of the module can be found in section "Technical data".

3.1 Connectors

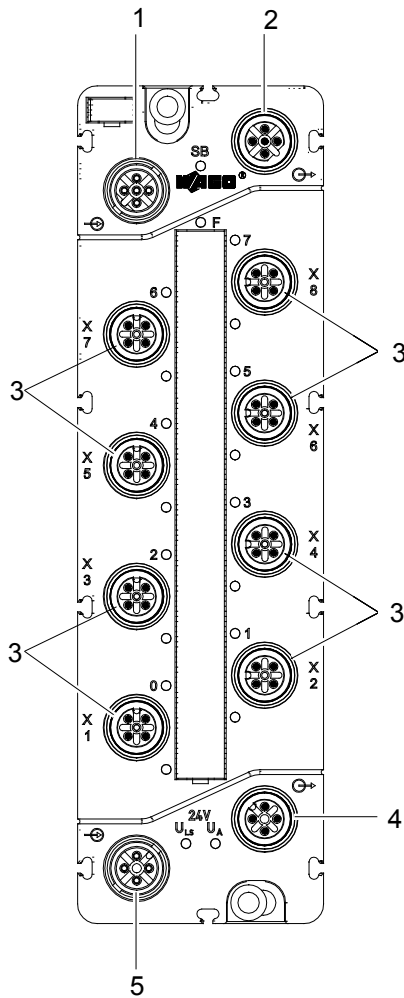

Figure 1: Connectors

Table 3: Legend for figure "Connectors"

Position	Description	Function
1	S-BUS input M12 plug, B-coded	For transmitting data from previous 767 Series components.
2	S-BUS output M12 socket, B-coded	For transmitting S-BUS data to the next 767 Series components or to the S-BUS terminator.
3	Digital inputs/outputs X1 - X8 M12 socket, A-coded	For connecting digital sensors or actuators, as well as for using counter functions.
4	Supply output M12 socket, A-coded	To use the Logic-/Sensor-supply and/or actuator supply for the following I/O modules.
5	Supply input M12 plug, A-coded	For feeding in both U_{LS} (logic and sensor supply) and U_A (actuator supply).

3.2 Marking Possibilities and Fastening

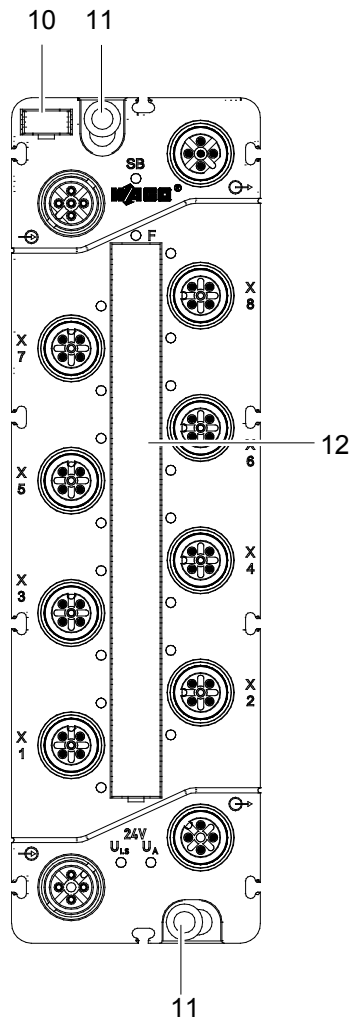

Figure 2: Marking possibilities and fastening (exemplary)

Table 4: Legend for figure "Marking possibilities and fastening"

Position	Description	Function
10	Module marker card	For identifying the module within a fieldbus node.
11	Mounting holes	With integrated function earth (FE) socket for fastening and grounding the module.
12	Marker strips	For identifying inputs.

3.3 Display Elements

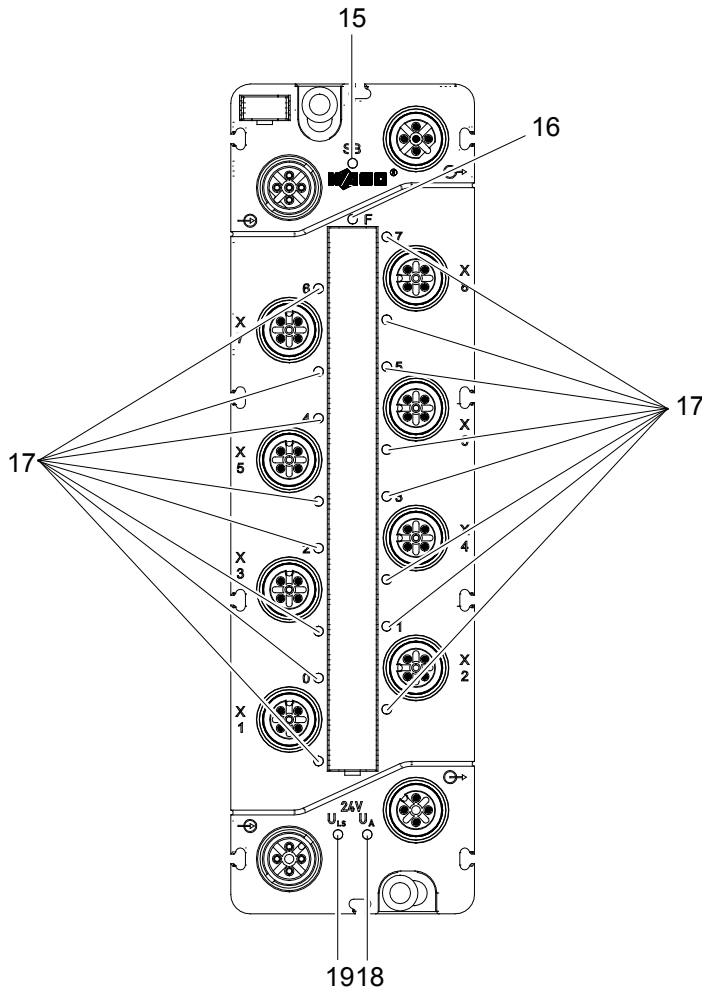

Figure 3: Display elements (exemplary)

Table 5: Legend for figure "Display elements"

Position	LED	Color	Meaning
15	SB	Green/red/orange	S-BUS status
16	F	Red	Diagnostic information
17	0 bis 7	Yellow/red	Status signal inputs/ outputs
18	U _A	Green	Actuator supply is present.
19	U _{LS}	Green	Logic supply and sensor supply are present.

Note



Detailed information

Detailed information can be found in section "Diagnostics" > "LED Signaling".

3.4 Labeling

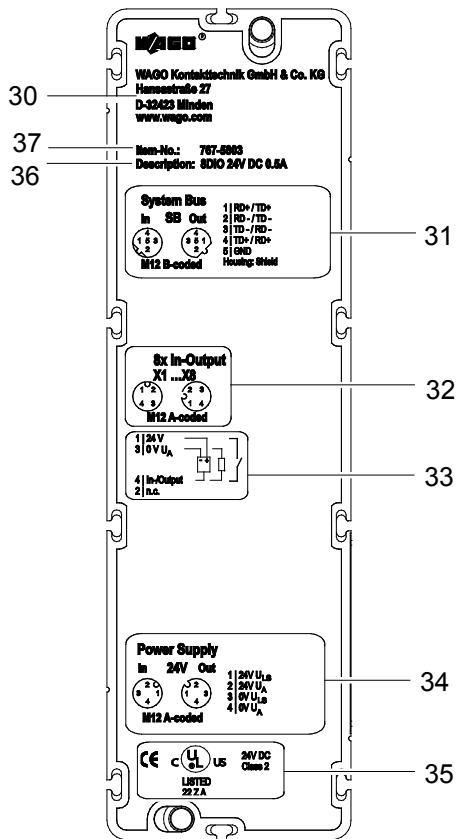

Figure 4: Labeling (example)

Table 6: Legend for figure "Labeling"

Position	Description
30	Manufacturer's mailing address
31	Connection assignment of S-BUS
32	Connection assignment of digital inputs and outputs
33	Connection diagram of digital inputs and outputs
34	Connection assignment of supply input and output
35	Information on approvals and CE marks
36	Unambiguous identification of module
37	Item number

On the side of the module is a label, with information that would prove useful in the case of a complaint:

- BA: Work order number (40)
- SN: Serial number (40)
- Manufacturing number (41)

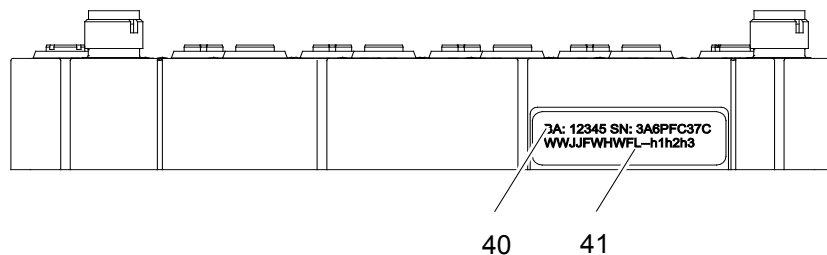

Figure 5: Label on the module

Table 7: Description of manufacturing number

Abbreviation	Description
WW	Week of production
JJ	Year of production
FW	Firmware release index When updating the firmware, please note that, the firmware release index may not be conformed to the printed firmware release index on the side of the fieldbus coupler. The “Electronic Type Label” (see section “Electronic Type Label”) shows the actual firmware release index.
HW	Hardware release index
FL	Firmware loader release index
h1h2h3	Internal manufacturer information

3.5 Schematic Diagram

The following schematic diagram provides an overview of the power supply and principle of operation of the power supply connections, as well as the digital inputs and outputs of the modules (see also chapters "Connecting the Supply Cable" and "Connecting the Sensor/Actuator Cable").

Please note, that the power supply of the sensors and actuators together from U_A is done and is distributed to all module ports (each pin 1).

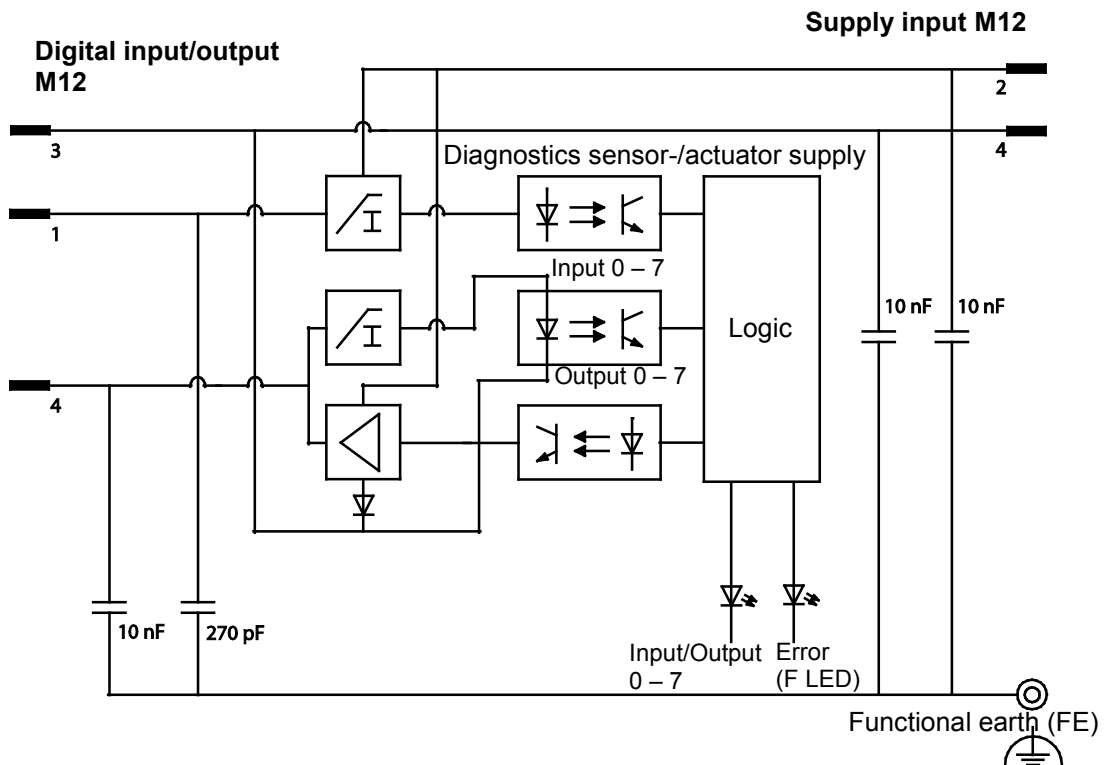

Figure 6: Schematic diagram

3.6 Dimensions

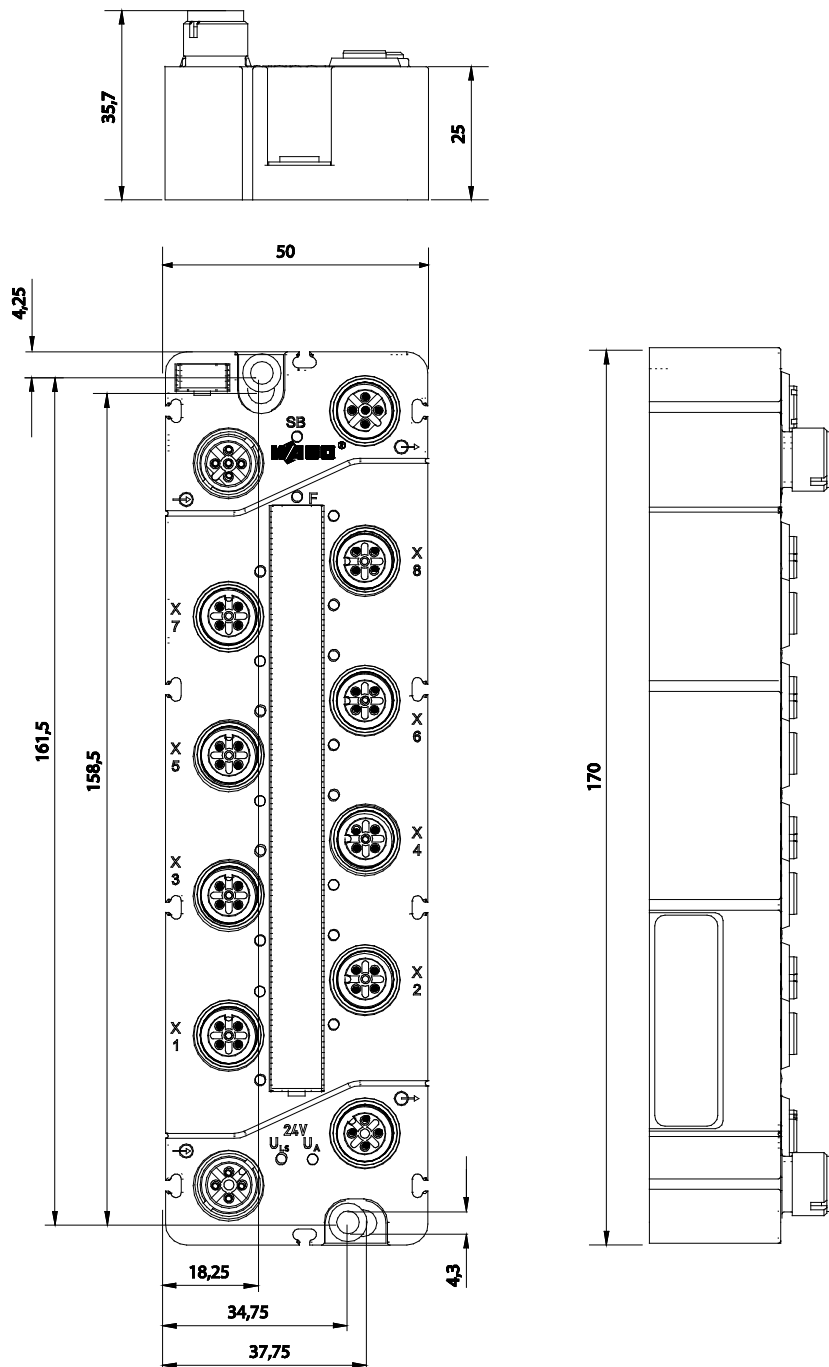

Figure 7: Dimensions of the module in millimeters (exemplary)

3.7 Technical Data



Note

Different technical data for applications in hazardous areas!

If the device is used in an application in the hazardous area, the technical data contained in the ATEX/IECEX certificate are binding in this application!

3.7.1 General Information

Table 8: Technical Data – General Information

Width	50 mm
Height	35.7 mm
Lowness	170 mm
Weight	389 g

3.7.2 Supply

Table 9: Technical data – Supply

Connection type	M12 connectors, A-coded, 4 poles*
Current carrying capacity of the supply connections	Maximum 8 A (U_{LS} : 4 A, U_A : 4 A)
Supply voltage Logic and sensor voltage U_{LS} Actuator voltage U_A	24 V DC (-25 % ... +30 %) 24 V DC (-25 % ... +30 %)
Supply current Logic and sensor current I_{LS} Actuator current I_A	Typically 45 mA (logic component only) Typically 75 mA + sensors/actuators (max. 800 mA) + load Note: heed the maximum total current of ≤ 4 A
Protection	Reverse voltage protection for $U_{LS} + U_A$ Short-circuit protection for sensor/actuator supply

* Derating must be observed

3.7.3 Communication

Table 10: Technical data – Communication

S-BUS connection	Shielded M12 connector, B-coded, 5 poles
------------------	--

3.7.4 Inputs

Table 11: Technical data – Inputs

Number of inputs	8
Connection type	M12 connectors, A-coded, 4 poles
Wire connection	2- or 3-wire
Input filter	Hardware: $\leq 60 \mu\text{s}$ Software: parametrizable
Input characteristic	Type 1, acc. to IEC 61131-2
Signal voltage (0)	-3 V DC ... +5 V
Signal voltage (1)	+15 V DC ... +30 V
Input circuit	high-side switching
Input voltage	24 V DC ($-3 \text{ V DC} < U_{\text{IN}} < +30 \text{ V DC}$) Power from sensor/actuator supply U_{A} strongly recommended, recovery for voltages $> U_{\text{A}}$
Input current	Typically 3.0 mA
Connection of 2-wire BEROs	Maximum of 1.5mA admissible closed current
Cable length, unshielded	$\leq 30 \text{ m}$

3.7.5 Input Characteristic

Table 12: Technical data – Input Characteristic

Input voltage	Typical input current
0 V DC	0
5 V	0.6 mA
11 V	2.6 mA
24 V	3.0 mA
30 V	3.2 mA

3.7.6 Outputs

Table 13: Technical data – Outputs

No. of outputs	8
Connection type	M12 connectors, A-coded, 4 poles
Wire connection	2- or 3-wire
Output voltage	$\leq U_A$
Output current (per channel)	0.5 A (max. 0.6 A), short circuit/overload proof (thermal disconnection)
Voltage drop against V_A at 500 mA	Maximum 0.2 V DC
Output current (module)	Maximum 4 A
Leakage current when switched off	Typically 5 μ A
Output circuit	high-side switching

3.7.7 Information on actuator selection

Table 14: Technical data – Information on actuator selection

Delay time hardware from 0 to 1 (0 – 90 %) from 1 to 0 (0 – 90 %)	90 μ s (resistive load) 310 μ s (resistive load)
Rise time from 0 to 1 Fall time from 1 to 0	Typically 60 μ s (resistive load) Typically 45 μ s (resistive load)
Cable length, unshielded	\leq 30 m
Resistance to recovery	\leq 0.5 A (error: 1 channel)
Type of load	Inductive, resistive loads and lamps
Switching frequency	Inductive load, approx. 20 Hz Resistive load, approx. 500 Hz Lamp load, approx. 500 Hz
Recommended minimum load	50 mA*
Parallel connection of 2 outputs	For power boost for redundant actuation of a load
Type of protective circuit	External protection (e.g., recovery diodes)
Output resistance	$<$ 0.4 Ω

* Wrong diagnostics may occur at high switching frequencies with reduced load.

3.7.8 Operating state influence on output

Table 15: Technical data – Operating state influence on output

PLC CPU stop	Acc. to substitute value strategy
Interruption of field bus	Acc. to substitute value strategy
Interruption of S-BUS	0 V status
Supply voltage under rated voltage tolerance	0 V status
Interruption of supply voltage	0 V status
Output operation	Non-latching
Overload behavior	Automatic restart

3.7.9 Counter 1 and 2 (configurable)

Table 16: Technical data – Counter 1 and 2 (configurable)

Event counter/Gate time measurement/pulse duration counter	
Connection	2 of 8 channels configurable as a counter input
Number (configurable)	2
Waveform	Rectangular pulses
Counting depth	16 bits
Counting/switching frequency	0 Hz ... 1 kHz (depending on the S-BUS cycle)

3.7.10 Configurable Functions

Table 17: Technical data – Configurable Functions

Operating mode (per module)	Output module Input module Input and output module Input and output module + 1 counter Input and output module + 2 counter
Input filter (per channel)	0.1/0.5/3/15/20 ms Filter off
Inversion (per channel)	on/off
Substitute value strategy (per channel)	Switch substitute value / hold last value
Substitute value (per channel)	0/1
Manual mode (per channel)	on/off
Manual mode value (per channel)	0/1
Online simulation per channel per channel/per module	Lock/unlock; simulation value: 0/1 Diagnostics

3.7.11 Configurable functions for counters

Table 18: Technical data – Configurable functions for counters

Counter mode	- Event counter - Gate time measurement - Pulse duration counter
Gate time basis	- 1 ms - 10 ms - 100 ms - 1 s - 10 s
Gate, Configuration via ...	- Process data - Digital input
Gate	- Enabled - Disabled
Count direction, Configuration via ...	- Process data - Digital input
Count direction	- Forward - Backward
Allow counter overflow (jump from 65535 -> 0 or from 0 -> 65535)	- Disabled - Enabled
Counter start value / limit value	Value: 0 ... 65535
Set start value/limit value Count direction forward: Set counter value to 0. Limit value is to be specified. Count direction backward: Start value is to be specified	Set value
Limit value output Count direction forward: Limit value output is set active upon reaching the counter value "Limit value" Count direction backward: Limit value output is set active upon reaching the counter value 0	- Do not use - Use
Limit value reset Count direction forward: Set counter value to 0 upon reaching limit value Count direction backward: Set counter value to start value at counter value 0	- Disabled - Enabled
Counter reset (when limits are exceeded)	- Disabled - Enabled

Table 18: Technical data – Configurable functions for counters

Toggle limit status	- Disabled - Enabled
---------------------	-------------------------

3.7.12 Diagnostics

Table 19: Technical data – Diagnostics

Per module	Short circuit/overload field supply
Per channel	Overtemperatur
Per module	Undervoltage ($U_{LS} + U_A$)

3.7.13 Process Image

Table 20: Technical Data – Process Image

Process data width	Depends on operating mode
--------------------	---------------------------

3.7.14 Indicators

Table 21: Technical Data – Indicators

SB: S-BUS status	LED (green/red/orange)
F: Error status	LED (red)
0 ... 7 : Input and output signal status	LED (yellow)
0 ... 7 : Output diagnostics	LED (red)
$U_{LS} + U_A$: Supply status	LED (green)
Indicators	Non-retentive

3.7.15 Isolation

Table 22: Technical data – Isolation

Channel - Channel	No
U_{LS} , U_A , S-bus	500 VDC each

3.8 Approvals

The following approvals have been granted to 767-5803/000-800 module:

 Conformity Marking

 cUL_{us} UL508

The following Ex approvals are pending for 767-5803/000-800 module:



BVS 15 ATEX E098X

II 3 G Ex nA IIC T5 Gc

II 3 D Ex tc IIIB T90°C Dc

IECEX BVS 15.0083X

Ex nA IIC T5 Gc

Ex tc IIIB T90°C Dc

3.9 Standards and Guidelines

The module 767-5803/000-800 meets the following standards and guidelines:

EC EMC Directive	2004/108/EC
EMC CE-Immunity to interference	acc. to EN 61000-6-2
EMC CE-Emission of interference	acc. to EN 61000-6-4
Ex Directive	94/9/EC
Explosive atmosphere Devices – General requirements	EN 60079-0
Explosive atmosphere Equipment protection by type of protection "n"	EN 60079-15
Explosive atmosphere Equipment dust ignition protection by enclosure "t"	EN 60079-31
Explosive atmospheres General requirements	IEC 60079-0
Explosive atmospheres Equipment protection by type of protection "n"	IEC 60079-15
Explosive atmospheres Equipment dust ignition protection by enclosure "t"	IEC 60079-31

4 Mounting

The module can be fastened directly to your system using screws. It can also be mounted on a carrier rail using an adapter or fastened to a profile rail using a surface mounting profile.

For mounting on a flat surface, WAGO offers spacers to assist in the mounting process that can be inserted between the 767 Series components. This helps by providing sufficient mounting distance for compact direct mounting, as well as eliminating gaps where dirt could accumulate. A cable tie can be fastened through each of two mounts in the spacer, which together serve to relieve strain from the sensor or actuator cables.

4.1 Information on Mounting

The following information shall always be observed:

- Disconnect the power supply from the system before you start with installation.
- The maximum diameter of the drill hole of the module's mounting holes is not to exceed 4 mm. Otherwise, a full contact with function earth (FE) socket of the module not be guaranteed. This may lead to restrictions in the shielding.
- To protect the module from tensile forces that may arise, do not bridge spaces with it.
- Screw the module down only on flat contact surfaces to protect it from warping.
- Ensure that the connectors are not soiled during installation. Dirt and other such substances damage the contacts, allowing corrosion to develop.
- To avoid damaging the module, do not mount it in shear areas of moving devices.
- Arrange for a sufficient potential equalization in your system.
- Use all mounting holes to mount the module to your system so all FE (function earth) connections lie on a ground potential.

Any mounting position is possible.

Note



Ensure a safe mounting position!

In explosion hazardous environments no increased mechanical loads must be present at the installation location. If shocks are possible, a shock protection must be installed between the module and the possible source of the shock.

4.2 Tools and Accessories Required for Mounting

Depending on the mounting type, the following tools are required for installation:

- A screwdriver for M4 fixing screws
- Drilling machine to pre-drill the mounting holes for the module to be mounted to the system and, if applicable, for the imperforated carrier rail.
- M4 thread cutter (bottoming tap or hand tap set)

The WAGO accessories listed below are required for mounting. The associated item numbers can also be found in the 767 Series fieldbus manuals, in the "Accessories" section. Select the manual appropriate to the fieldbus you are using.

- Carrier rail adapter, including fixing screws and perforated or imperforated carrier rails (DIN rail 35 x 7.5 or DIN rail 35 x 15) according to EN 60715, also available from WAGO.

or

- Profile adapter, including fixing screws
- Spacer (optional)

Two M4x12 screws are required for direct mounting of the module. The length of the screw shaft is to be selected according to the mounting type.

Bore measurements

When fastening the 767 Series components without a threaded hole, the clearance hole must not be wider than 4 mm so as to ensure safe contact of the FG (functional ground) connections.

4.3 Direct Mounting on Your System

Mount the module directly on a level surface of your system, without using WAGO accessories. Direct mounting of the module is to be carried out as follows:

1. Disconnect the power supply from those devices on which you wish to mount the module.
2. Mark the drill holes using the hole drilling template printed on the packaging. You can also hold the module in the desired position and mark the drill holes. Ensure that there is sufficient space around the 767 Series components to enable you to connect all cable without problems.

Note



Direct Mounting

We recommend using WAGO spacers for compact direct mounting. If these are used, the resulting additional distance from the second 767 Series component is to be noted. See section “Mounting the Module” > “Mounting the Spacer in the Case of Compact Arrangement”.

3. Fasten the module with two M4x12 screws via the two mounting holes.

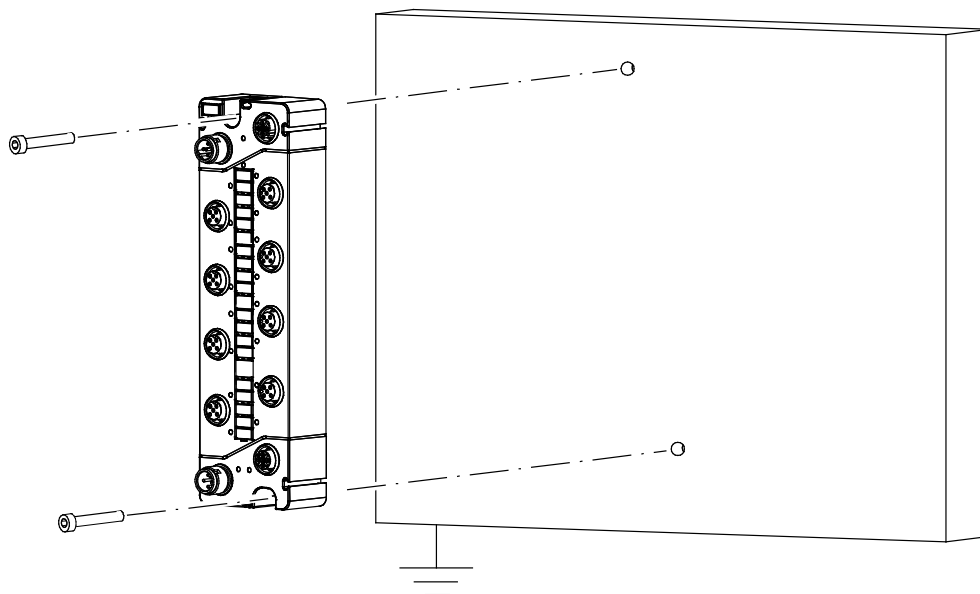

Figure 8: Mounting the module on the grounded system

4.4 Mounting on a Carrier Rail (only with WAGO Accessories)

4.4.1 Fastening the Carrier Rail Adapter to the Module

A carrier rail adapter is required to mount the module on carrier rails.

Screw together the module and carrier rail adapter using the M4 threaded screws provided, as shown in the figure below.

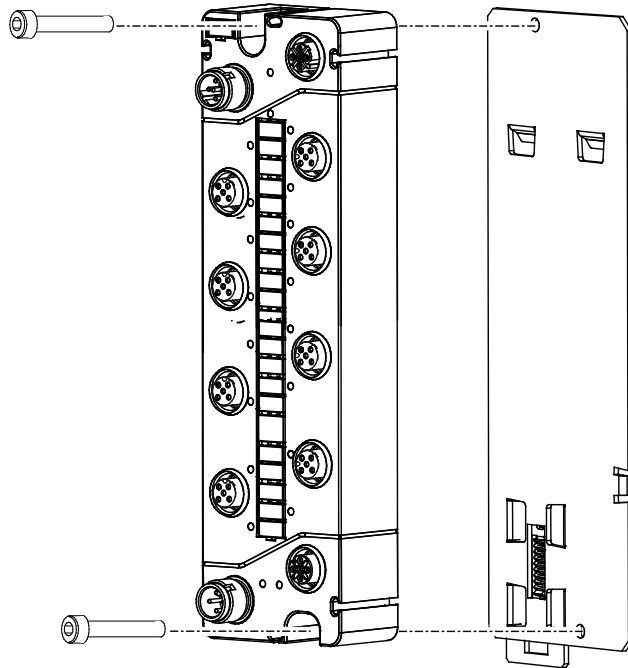

Figure 9: Fastening to the carrier rail adapter

4.4.2 Fastening the Module with Carrier Rail Adapter to a Carrier Rail

In order to provide a clear representation, the carrier rail adapter in the figure below is shown without module.

When mounting the module to a carrier rail (DIN rail 35 x 15) using a carrier rail adapter, proceed as follows:

1. Disconnect the power supply from those devices on which you wish to mount the module.
2. Set the module onto the edge of the carrier rail (51) with the two notches (50).
3. Press the undersurface against the lower carrier rail edge until the latch (52) locks in place.

Note



Rail Adapter for 767 modules with 8xM12 connections

If a 767 module with 8xM12 connections with a rail adapter (item no.: 767-0125) mounted on a DIN rail, a mounting rail 35 x 15 for use with a height of 15 mm.

Note



Use end stops

When mounting the rail vertically or if shock or vibration loading should occur, the use of end stops (item no.: 249-116 or 249-117) for stabilization is required.

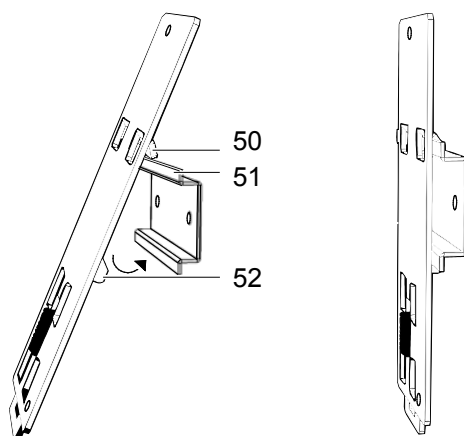

Figure 10: Mounting the carrier rail adapter (exemplary)

4.5 Mounting on a Profile Rail (only with WAGO Accessories)

4.5.1 Fastening the Profile Adapter to the Module

Aside from using carrier rail adapters to fasten the module, you also have the option to fasten it to a profile rail using the profile adapter and nuts, provided that this mounting type is supported by your system. You are to supply the necessary nuts.

Screw together the module and the profile adapter using the M4 threaded screws provided, as shown in the following figure.

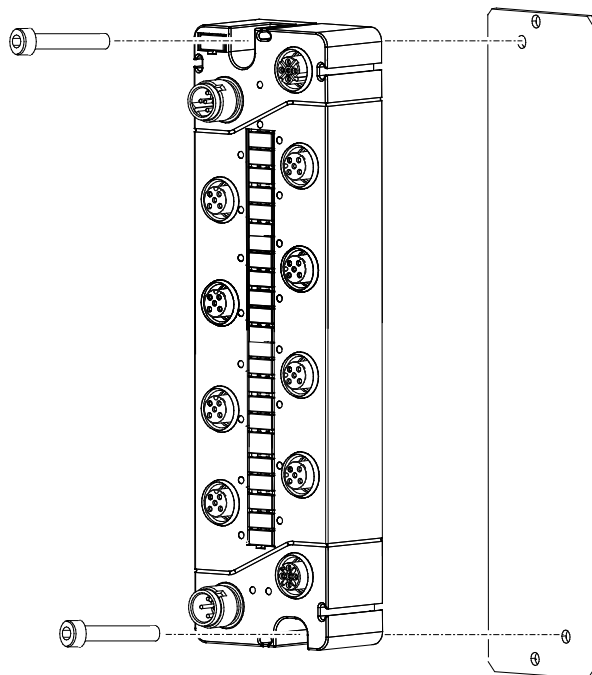

Figure 11: Fastening to the profile adapter

4.5.2 Fastening the Module with Profile Adapter to a Profile Rail

To fasten the module to a profile rail of your system, two nuts are required with one screw each (length of screw threads must be compatible with your system).

1. Disconnect the power supply from those devices on which you wish to mount the module.
2. Insert the two screws into the holes above and beneath the fastened module on the profile adapter.
3. Fasten an appropriate nut on each of these screws.
4. Insert the profile adapter with the attached module into the profile rail of your system. Position it and tighten the screws.

4.6 Marking and Replacing the Marking Spaces

The module marker card (10) and marking strip (12) are attached when delivered. The protective cover is to be removed when labeling the marking strip. To do this, proceed as follows:

1. Press the slot screwdriver (maximum slot width: 3mm) into the small opening under the marking strip cover (12) and lever it up.
2. Remove the marking strip cover.
3. Mark the marking strip with a waterproof pen.
4. Reinsert the marking strip cover and press it firmly in place.

If the module's marker card (10) must be replaced, proceed in accordance with the step sequence described previously. New module marker cards can be obtained through WAGO.

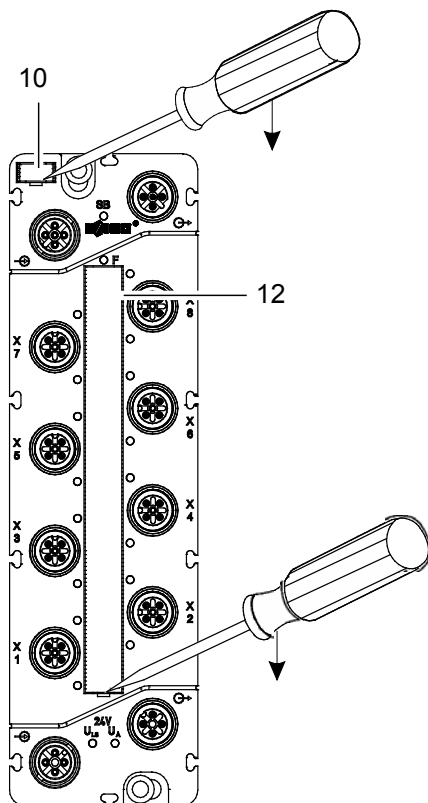

Figure 12: Replacing the marking spaces

4.7 Mounting the Spacer in the Case of Compact Arrangement

By using the spacer, a sufficient mounting distance can be achieved when directly mounting the 767 Series components, and gaps can be eliminated where otherwise dirt and other substances could accumulate. In addition, it is possible to optimize the cable routing. For this purpose, two fastening lugs each are included on the spacer for cable ties.

1. Disconnect the power supply from those devices on which you wish to mount the module.
2. The spacer can only be inserted into the appropriate openings of the module from the bottom. To bind both components, place the module on the spacer or push the spacer from the bottom into the module.
3. Fasten the attached components on a flat surface by fastening the module to the grounded frame of your system or to another grounding point with two M4 screws via the mounting holes.

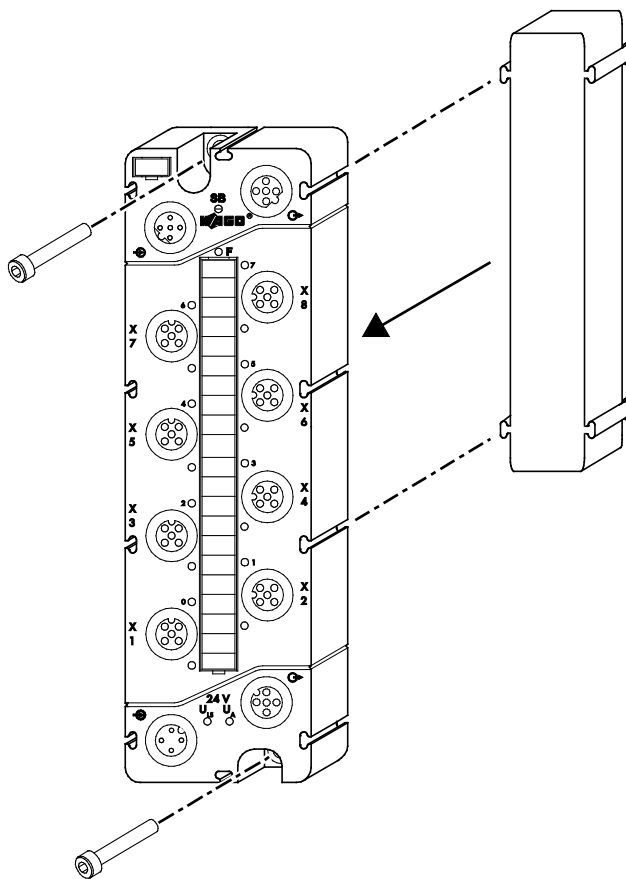

Figure 13: Attaching a spacer to a module

4. When attaching 767 Series component, only one 767 component connected with a spacer can be attached and screwed on to the preceding component due to the mounting direction. The last 767 component is fastened without a spacer.

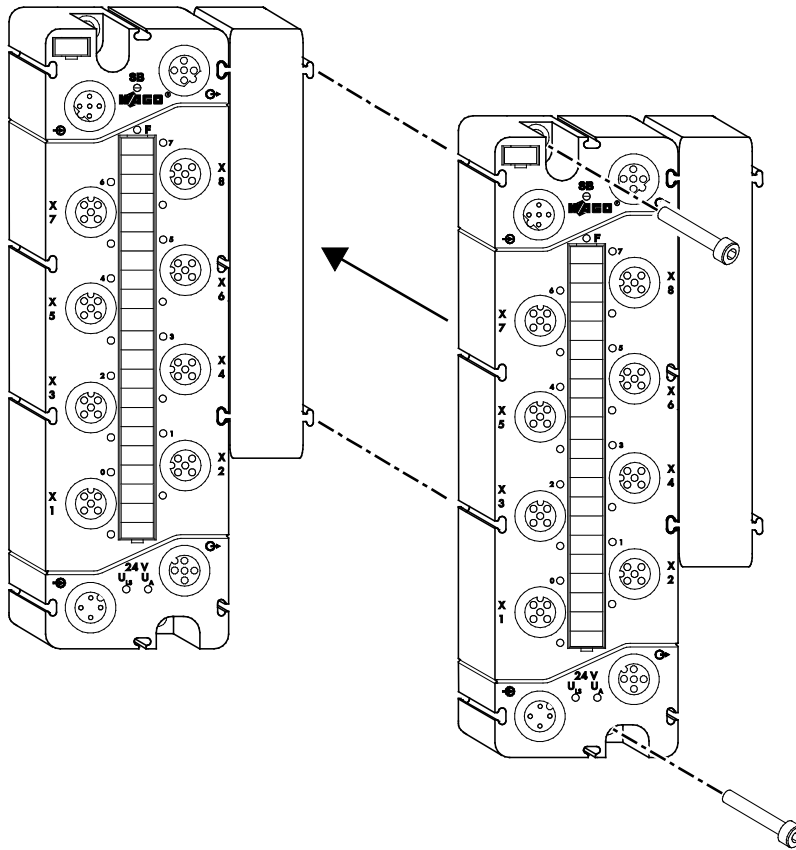

Figure 14: Attaching another module with a spacer

5 Connecting Data and Supply Cables

5.1 Notes



DANGER

Electric voltage!

Operate the 767 Series components exclusively with 24 VDC PELV (Protective Extra Low Voltage) or SELV (Safety Extra Low Voltage) voltage sources. Failure to comply may result in electric shock.

NOTICE

The highest current carrying capacity of the supply contacts is 4 A!

Always observe the maximum current carrying capacity per supply line (U_{LS} , U_A) for each 767 Series component and the overall power consumption for all 767 components. Neither of these values shall exceed 4 A since an increase in current causes the contacts to overheat and damages the 767 Series components. Information regarding the power demand of each 767 Series component can be found in the corresponding data sheet, which is available from www.wago.com.

NOTICE

Exposed connections!

If connections have not been closed with protective caps, liquid or dirt can penetrate the components of the 767 Series module and ruin it. Therefore, close all unnecessary connections with protective caps, which must be ordered separately, in order to maintain the IP67 degree of protection. (See section “Accessories” of the fieldbus coupler/controller manual.)

- The connectors must be disconnected from the power supply when screws are tightened.
- Tighten the connectors by hand. To achieve the required torque (see below) for the connector, use the torque wrench with the order number **206-701**.

Torque for M8 connectors:	0.6 Nm
Torque for M12 connectors:	1.0 Nm

NOTICE

Use torque wrench 206-701!

Only use the specified torque wrench. Using mechanical tools can cause the threads to strip.

In this case, replace the module!

- For both power supply and S-BUS, use only pre-assembled WAGO system cables so the specified characteristics of the technical data can be achieved.

- Do not use drop lines under any circumstances. This can lead to amplified line reflections and signal distortions, which greatly impair the transmission quality.
- Observe the exact positioning (coding) between plug and socket.
- Keep all cables a sufficient distance away from electromagnetic sources of interference in order to maintain a high level of interference resistance of the 767 system against electromagnetic emissions.
- Observe the minimum bending radiuses of the WAGO system cable. For more information, see the technical data at www.wago.com.
- When laying all cable, ensure that you do not lay it in shear areas of moving machine parts.
- Observe the correct layout of the potential equalization.

5.2 Required Accessories

The WAGO accessories listed below are required for connecting the data and supply cable. The associated item numbers can also be found in the fieldbus manuals for 767 Series, in the "Accessories" section. Select the manual appropriate to the 767 Series fieldbus you are using.

- S-BUS M12 terminator, IP 67
- S-BUS and supply cables, pre-assembled on both ends, IP 67
- Torque wrench
- Protective caps

5.3 Connecting the S-BUS Cables

The S-BUS is used for communication between a fieldbus coupler and the connected 767 Series components.

Requirement:



- A WAGO S-BUS cable pre-assembled on both ends is readily available to you. This is necessary for optimal signal transmission.
- The S-BUS terminator is available to you, which is necessary for communication.

The following table outlines the assignment of the S-BUS connections:

Table 23: S-BUS connection assignment

Connection		Contact	Description	
			IN	OUT
		1	RD +	TD +
		2	RD -	TD -
		3	TD -	RD -
		4	TD +	RD +
		5	GND	
		Connecting thread	Shield	

To connect the S-BUS cables to fieldbus coupler and I/O modules, proceed as follows:

1. Disconnect the power supply from those devices on which you have mounted the module.
2. Connect the S-BUS cable (S1) with the OUT connection  (3) of the fieldbus coupler and the IN connection  (1) of the module. For example, if two I/O modules have been connected to the fieldbus coupler, connect the S-BUS cables (S1, S2) to the associated IN and OUT connections, as shown in the following figure.
3. Tighten the plugs and sockets using the knurled-head screws.
4. Attach the S-BUS terminator (T) to the last I/O module as shown in the figure and tighten it.

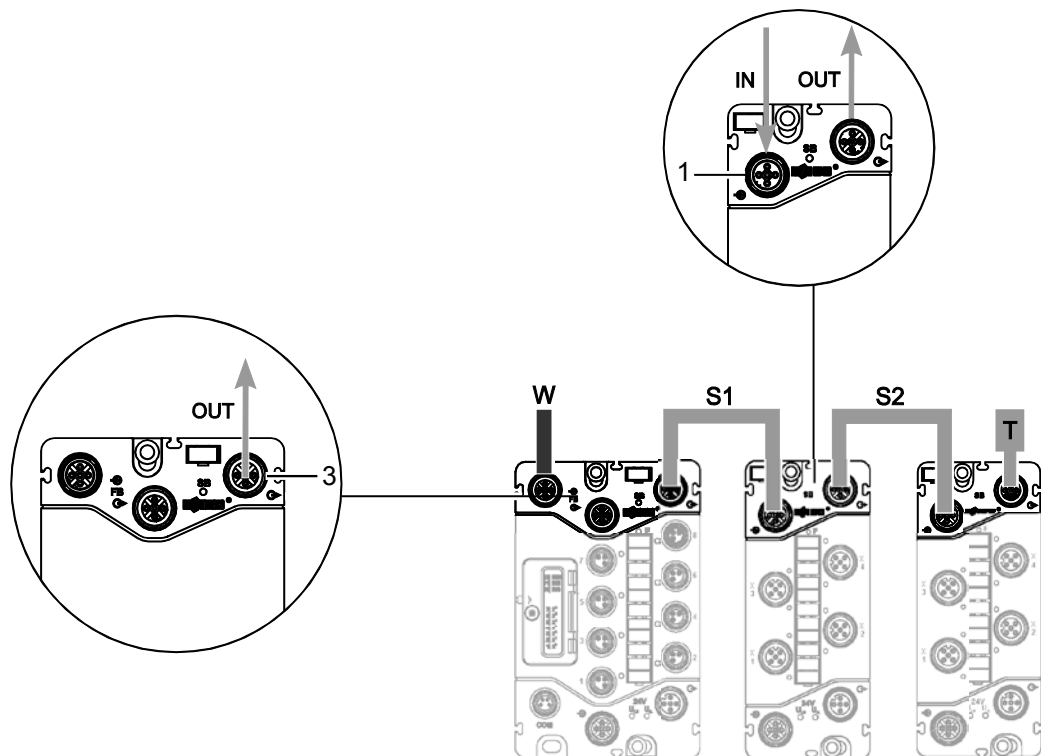

Figure 15: S-BUS connected to a fieldbus coupler and modules

5.4 Connecting the Supply Cable

The supply cable provides power to the module.

Requirement:

The WAGO supply cables K1 and K2, which are pre-assembled on both ends, must be available (see figure on next page).

The following table outlines the assignment of the supply connections:

Table 24: Supply connection assignment

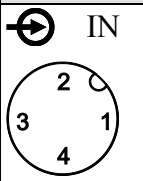
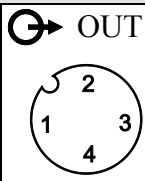
Connection		Contact	Description
		1	24 VDC U_{LS}
		2	24 VDC U_A
		3	0 V U_{LS}
		4	0 V U_A

NOTICE

The highest current carrying capacity of the supply contacts is 4 A!

Always observe the maximum current carrying capacity per supply line (U_{LS} , U_A) for each 767 Series component and the overall power consumption for all 767 components. Neither of these values shall exceed 4 A since an increase in current causes the contacts to overheat and damages the 767 Series components. Information regarding the power demand of each 767 Series component can be found in the corresponding data sheet, which is available from www.wago.com.

Hinweis



Sensor/ Actuator Supply

Please note that the sensor/actuator supply is jointly performed from the U_A voltage and that the U_{LS} voltage is only used for the logic supply.

To connect the supply cable to the fieldbus coupler and modules, proceed as follows:

1. Disconnect the power supply from those devices on which you have mounted the module.
2. Connect the power supply cable (K1) to the **OUT** connection (9) of the fieldbus coupler and the **IN** connection (5) of the module.
For example, if two modules have been connected to the fieldbus coupler, connect the power supply transmission cable (K1, K2) with the associated IN and OUT connections, as shown in the following figure.
3. Tighten the plugs and sockets using the knurled-head screws.
4. Screw a protective cap on all unused ports to ensure that IP 67 degree of protection is provided.

Information on connecting the power supply cable (K0) to the "IN" port **IN** (6) of a fieldbus coupler can be found in the appropriate manuals.

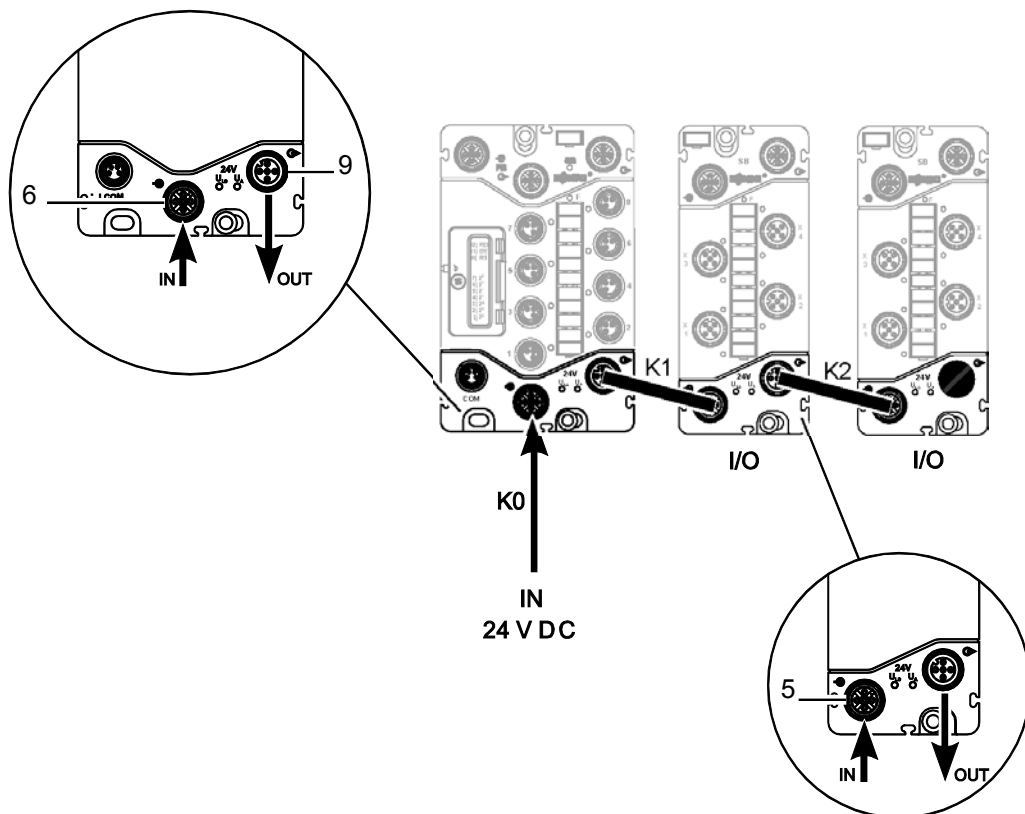

Figure 16: Supply cable connected to a fieldbus coupler and modules

5.5 Connect Sensor/Actuator Cable

The sensor/actuator cable provides power to the connected sensors and actuators.

When using cables that have not been pre-assembled, make sure that these cables are equipped with M12 plugs rated to IP67. The following table outlines the assignment of the sensor/actuator connections:

Table 25: Digital inputs/outputs: connection assignment

Connection		Connection diagramm
IN/OUT  X1, X3, X5, X7	IN/OUT  X2, X4, X6, X8	1: 24 V 3: 0 V U _A  4: In-/Output 2: n.c.

Table 26: Counter: Assignment of channels for connection assignment

Channel	Connection	Counter
1	X1	1
2	X2	
3	X3	
4	X4	
5	X5	2
6	X6	
7	X7	
8	X8	

NOTICE

The highest current carrying capacity of the supply contacts is 4 A!

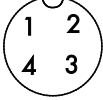
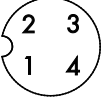
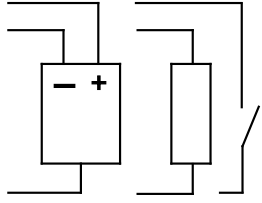
Consider that the sensors and actuators are supplied with power from the U_A supply line. Take into account when determining the current energy needs of the U_A supply line, the sensor and actuator power consumption.

NOTICE

The total maximum power consumption of the sensors/actors must not exceed 800 mA!

Please note that the combined power consumption of all connected sensors/actors is not to exceed 800 mA. The distribution of power among the existing connections is depending on the individual power requirements of the sensors/actors.

To connect the sensors/actuators to the digital inputs/outputs (X1 – X4) proceed as follows:

1. Disconnect the power supply from those devices on which you have mounted the module.
2. Insert the plug of the sensor or actuator cable into the socket of a digital input/output (3) of the module and tighten it using the knurled-head screw.
3. Screw a protective cap on all unused connections to ensure that the IP 67 degree of protection is adhered to.

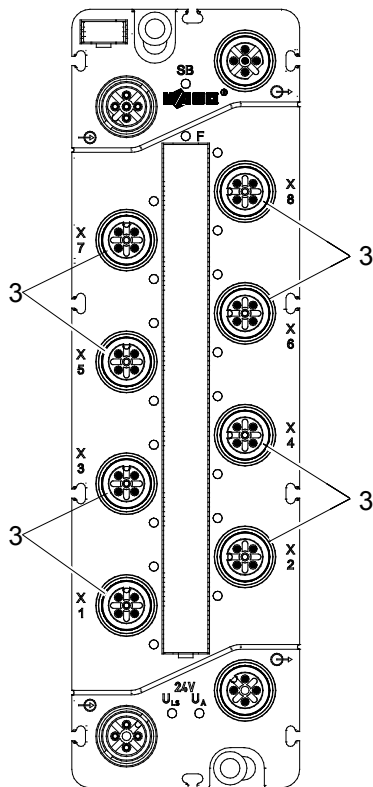

Figure 17: Connectors (exemplary)

6 Commissioning

NOTICE

Exposed connections!

If connections have not been closed with protective caps, liquid or dirt can penetrate the components of the 767 Series module and ruin it. Therefore, close all unnecessary connections with protective caps, which must be ordered separately, in order to maintain the IP67 degree of protection. (See section "Accessories" of the fieldbus coupler/controller manual.)

Before starting up the 767 node, ensure that the following requirements are met:

- Both 767 Series Fieldbus Coupler and Module 767-5803/000-800 have been properly mounted (See also fieldbus coupler manuals Series 767).
- The fieldbus, all necessary supply and sensor lines, and the S-BUS bus terminator are all securely fastened onto the appropriate connections (see section "Connecting Data and Supply Cables").
- An appropriate potential equalization is implemented in your system.
- Shielding is carried out properly.

7 Parameterizing

All parameters listed here can be set using WAGOframe (or another FDT/DTM frame application) for the module.

If you use a fieldbus for the parameterization, only certain parameters are configurable, depending on the type of fieldbus.

DANGER

Changing parameters!

When parameters are incorrectly modified via FDT/DTM frame application (e.g., WAGOframe), machine components could be placed in a dangerous state and personnel and machines could be at risk.

Before changing the parameters, ensure that the machine components are in a safe and defined state and switch off the higher-level controller.

Also ensure before start-up that no personnel remain in the danger area of the machine components.

For the parameterization of the module, an appropriate DTM is available. Via this DTM, you can parameterize the module either online or offline. The offline mode enables the parameterization of a module that is not yet present. In the offline mode, first store the parameters in a project and later transfer them to the module.

In the online mode there is a direct link between the display and the connected module. If the module is in the online mode, its name is displayed in **bold** and *italic* font in the network window.

Note



Detailed informations.



Detailed information on handling WAGOframe can be found in the fieldbus coupler manuals.

The following sections provide information on the parameters and their descriptions.

To open the parameterization user interface (DTM) of the module, double-click on the module in the "Network View" of WAGOframe. The parameterization user interface can also be opened by right-clicking on **Offline Parameter** or **Online Parameter** in the context menu.

If several DTMs are open, select one via the corresponding tabs. Depending on the DTM you have selected, different buttons are provided:

Table 27: DTM buttons

Buttons	Description
[Read] (Online mode only)	Reads and displays the parameters found in the module.
[Write] (Online mode only)	Writes the modified values to the module.
[Close] (Online and offline mode)	Closes the parameterization user interface (DTM).
[Apply] (Offline mode only)	Applies the entries in the project. Please note that the project should also be subsequently saved (File > Save).
[Help] (Online and offline mode)	Opens the online help for an entry that has been previously selected in the DTM (e.g., digital inputs, global setting).
	Shows/hides parameter overview.
	Displays the product data sheet. A PDF reader must be installed on your PC.
	Opens the DTM online help.

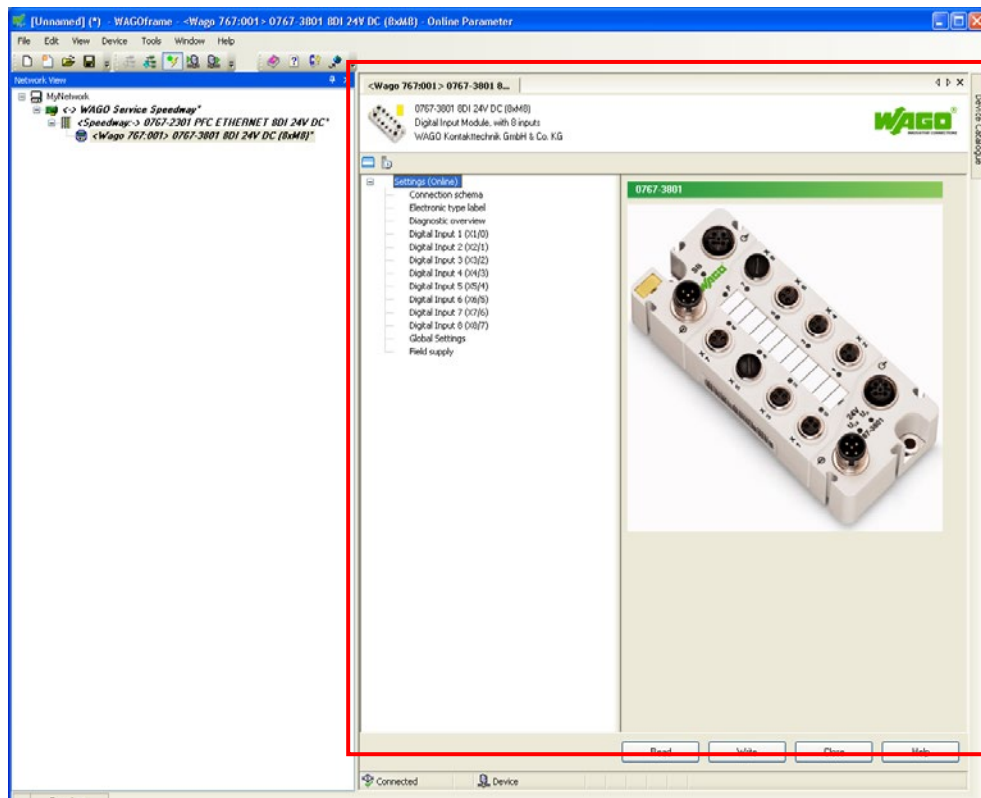

Figure 18: Example of an open DTM, including parameters

7.1 Electronic Type Label

Table 28: Information on the module

Parameter	Description
Vendor	Manufacturer
Release index	FW.HW.FL FW: Actual firmware release index. When updating the firmware, please note that the firmware release index may not be conformed to the printed firmware release index on the side of the fieldbus coupler. HW: Hardware release index FL: Firmware loader release index
Firmware revision	General information on the module
Order number	
Description	
Serial number	
Date of production	
Designation	Electronic marking field

7.2 Diagnostic Overview

The currently pending diagnostics existing on the module are displayed here. In this view of the DTM, you can enable simulation of the diagnostics, as well as disable transmission of the diagnostics. When disabling transmission, make sure that the display behavior of each LED changes that indicates the specific diagnostics (section "Diagnostics" > "LED Signaling"). The diagnostic overview is only available in online mode.

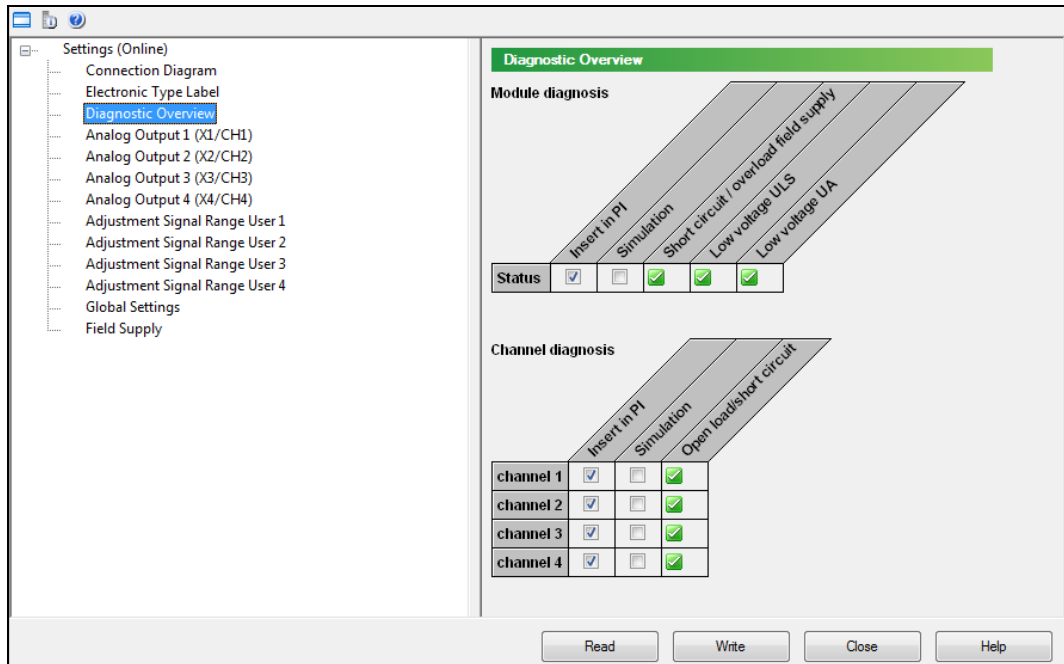

Figure 19: Example of the diagnostic overview of a module (information may differ from the actual module)

Table 29: Diagnostics setup

Parameter	Description
Insert in PI	By unselecting the checkbox, you specifically suppress evaluation and transmission of individual diagnostics. Doing so has no effect on the size of the process image. Even if a diagnostics has occurred, the diagnostic value "0" (no error) is transmitted to the higher-level controller.
Simulation	If you have selected the "Insert in PI" checkbox, the "Simulation" parameter is released. You can select the diagnostics you want to simulate. Click the [Write] button to transfer the simulated values to the module.
Status	Displays whether there is a diagnostics: X mark: There is a diagnostic message. Check mark: There is no diagnostic message.

Table 30: Information about existing module diagnostics

Global Diagnostics	
Diagnostics	Description
Low voltage of U_{LS}	<p>⚠ WARNING</p> <p>Disabling the outputs. If there is an undervoltage of U_A and/or U_{LS}, the module outputs are disabled. Machine components can be placed in a dangerous condition, as well as personnel and machine put in danger.</p> <hr/> <p>If an undervoltage of the logic and sensor supply U_{LS} of $< 18\text{ V}$ occurs on the module, the outputs are disabled and a corresponding diagnostic is transmitted to the fieldbus coupler. The F-LED of the module illuminates.</p>
Low voltage of U_{LS}	<p>⚠ WARNING</p> <p>Disabling the outputs. If there is an undervoltage of U_A and/or U_{LS}, the module outputs are disabled. Machine components can be placed in a dangerous condition, as well as personnel and machine put in danger.</p> <hr/> <p>If an undervoltage of the actuator supply U_A of $< 18\text{ V}$ occurs on the module, the outputs are disabled and a corresponding diagnostic transmitted to the fieldbus coupler. The module F-LED illuminates.</p>
Short circuit/ overload encoder supply	The module has detected a short circuit or overload of the encoder supply (only possible when field supply is switched on).

Table 31: Information about existing channel diagnostics

Channel Diagnostics	
Diagnostics	Description
Overtemperature	The module has identified overheating on the corresponding channel (1 – 8) (only enabled when the actuator output is switched on).

Note



Interruption of the S-BUS

If there is an interruption of the S-BUS, the module is automatically put in STOP mode. The module outputs are disabled.

7.2.1 Input and Output Parameters

Selecting the operating mode

Specify in which operating mode the module should be operated. When using e. g. DIO mode, each connection in the DTM can be configured as a digital input or output.

Table 32: Overview of operating modes

Parameter	Description
Operating type	DO module Operation as digital output module.
	DI module Operation as digital input module.
	DIO module (Default status) Operation as digital input and output module.
	DIO module + 1 counter Operation as digital input and output module with one counter.
	DIO module + 2 counters Operation as digital input and output module with two counters.

Note



Changing the operation mode



After changing the operation mode, reset the WAGO Speedway system.

7.2.2 "DO Module" Mode

Table 33: Overview of adjustable parameters for the digital outputs

Parameter	Description
Function mode	Mode display
Designation	Electronic marking field (max. 40 characters).
Output value	The output state is indicated in this field.
Process image value	This field indicates the value of the output process image for this output. When manual operation is activated, the field becomes a checkbox. Activate this checkbox in order to output the state "1" on the output independently from the control unit.
Signal inverting	Here you can release the current process value as an inverted output value. Checkbox unselected*: Output signal is released as indicated in process image Checkbox selected: Output signal is released in an inverted manner as indicated in process image
Substitute strategy	This releases the substitute value or the last output value in cases such as a disruption of the fieldbus. You have the following options: - Switch to substitute value* - Retain last value**
Substitute value	Enter the process value that is output in case of error. In case of error (e.g., fieldbus interruption), the value is used with the "Switch to substitute value" substitute value strategy. Checkbox unselected: 0* Checkbox selected: 1
Manual operation	Activate this checkbox to define the output value independently from the control unit. When manual operation is activated, the field for the process image value becomes a checkbox for the manual operation value.
Simulation diagnostics	Activate this check box to switch on the diagnosis simulation. When the simulation is switched on, the fields for the diagnoses become checkboxes.

Table 33: Overview of adjustable parameters for the digital outputs

Parameter	Description
Actuator restart mode	<p>Set the restart behavior of an enabled output if the output has been disabled due to the "Overtemperature" diagnosis. You have the following options:</p> <p>Delayed* After the time set has elapsed ("Restart delay, actuator"), the output is switched on again automatically.</p> <p>Diagnostic acknowledgement The output is only switched on after acknowledging the diagnostic message. Acknowledge the diagnostic message from the higher-level controller or PLC. The respective coupler manual specifies which fieldbus couplers this functionality supports.</p>
	<p style="text-align: center;">Note</p> <p> Information about diagnostic acknowledgement: When using fieldbus couplers that do not support the diagnostic acknowledgement, disabled outputs may remain OFF.</p>
Restart delay actuator	<p>Time in 100 ms intervals after which an off output is automatically restarted in case of error.</p> <p>You must unselect the checkbox under "Restart mode actuator" (0).</p> <p><i>Default setting: 10</i></p>
	<p style="text-align: center;">Note</p> <p> Note If you set the time of the "Restart delay actuator" parameter to 0 ms, the I/O LED appears yellow rather than red in case of a short circuit or overload due to the short restart interval (see section "Diagnostics").</p>
Overtemperature	The module has identified a overtemperature on the corresponding channel (1 – 8) (only enabled when the actuator output is switched on).

* Default status

** The last value is the value output to the contact before occurrence of the respective interruption. This can be, for example, a process value or manual operation value.

7.2.3 "DI Module" Mode

Table 34: Overview of adjustable parameters for the digital inputs

Parameter	Description
Function mode	Mode display
Designation	Electronic marking field (max. 40 characters)
Input value	The input state is indicated in this box. When simulation is switched on, the field becomes a checkbox. Activate this checkbox to simulate input state "1" independently from the input in the process image.
Signal inverting	You can invert the currently pending input signal here. Checkbox unselected*: Input signal is reproduced in the process image in the same manner as the input Checkbox selected: Input signal is reproduced in the process image in an inverted manner
Filter time	Set the input filter for the measured signals here. You have the following options: none 0.1 ms 0.5 ms 3 ms* 15 ms 20 ms
Simulation input value	Activate this checkbox to switch input simulation on. The field for the input value then becomes a checkbox for the simulation value.

* Default status

7.2.4 "DIO Module" Mode

Combined operation of digital inputs and outputs. For an explanation of the adjustable parameters for the digital outputs, see section "DO Module" and for the digital inputs section "DI Module".

7.2.5 "DIO Module with Counter" Mode

Table 35: Overview of adjustable counter parameters for the DIO Module

Parameter	Description
Counter value	This field indicates the counter status
Counter mode	The counter can be used in 3 modes: Event counter: The counter counts the detected pulse on the counter input. Gate time counter: The counter counts the pulse detected within the adjustable gate time on the counter input Pulse duration counter: The counter determines the pulse duration of the pending pulses in ms.
Peak time basis	In "Gate time counter" mode, you define the gate time: 1 ms 10 ms 100 ms 1 s 10 s
Gate input	Select here whether the counter should be controlled by the module inputs or by the process data: Digital input If you select this option, the counter is controlled by the module inputs (see section "Control of the Counter via Inputs and Outputs"). No* If you select this option, the counter is controlled by the process data (control byte). See section "Control Byte".
State Gate	The checkbox displays the current status of the gate function. If the checkbox is activated, the counter is released.
Up/down select input	Select here whether the count direction should be controlled by the module inputs or by the process data: Digital input If you select this option, the count direction is controlled by the inputs (see section "Control of the Counter via Inputs and Outputs"). No* If you select this option, the count direction is controlled by the process data (control byte). See section, "Control Byte".
Counter direction	Display of the current count direction of the counter or selecting the count direction with process data control: - Forward (0) - Backward (1)
Allow counter overflow	By default, the counter stops if the maximum value 65535 (count direction forward) or 0 (count direction backward) is reached. If this function is disabled, the counter restarts at 0 or 65535.

Table 35: Overview of adjustable counter parameters for the DIO Module

Parameter	Description
Start/limit value	Enter a value (0 - 65535), which is used as the start value or as a reference to control the switching output. <i>Default setting: 32768</i>
Switching output	Digital output If you select this option, the " Status limit value" is output as a digital signal (see section "Control of the Counter via Inputs and Outputs"). No*
Status limit value	Display if the limit value is reached (count direction forward/backward). Display whether the limit value set (up and down counter) is reached. The limit status is set if the counter value is exceeded or the value 0 is reached. The limit status is maintained until it is again cleared by the process data (control byte) or the DTM.
Reset limit status	The limit value status is reset by enabling this field. If the "Switching Output" parameter is selected, it is also reset.
Auto reset upon limit	If you enable this field, the counter is reset when the limit value is exceeded (forward counter = 1) or set to the initial value (backward counter = limit value set).
Toggle limit status	If this field is enabled, the limit value status is toggled between enabled and disabled status upon reaching the counter value.
Simulation	If simulation is switched on, you can simulate all values that appear in the process image. The display fields become input fields/checkboxes: <ul style="list-style-type: none"> - Counter status - Status Gate - Count Direction - Status of Limit Value Output

* Default status

The parameterization of the inputs (input, gate, counter direction) and outputs (limit output) of the respective counter is "DO mode module" or "Mode DI module" described in the section.

7.3 Global Settings

Table 36: Overview of parameters for the entire module

Parameter	Description
Simulation diagnostic	If the checkbox is selected, you can simulate a low voltage diagnostic. To generate a low voltage diagnostic, one or both of the two checkboxes "Low voltage U_{LS} " and "Low voltage U_A " must be selected. <i>Default setting: unselected</i>
Low voltage U_{LS}	In the case of an undervoltage of the logic and sensor supply (U_{LS}) or the actuator supply (U_A), the corresponding diagnostic is displayed here.
Low voltage U_A	

7.4 Parameters of Field Supply

Table 37: Overview of adjustable parameters for the field supply

Parameter	Description
Enable field supply	Switch on the field supply (24VDC) here. <i>Default setting: selected</i>
Autorestart delay	In the event of a short circuit, the sensor supply is switched off for a certain time. Here, enter this delay time (in 100 ms increments) after which the sensor supply is restarted. If the short circuit still exists, the process is repeated.
Simulation diagnostic	The simulation can be used to simulate a short circuit. <i>Default setting: unselected</i>
Short circuit/overload	If simulation is deactivated, the respective error is displayed upon emergence. If simulation is activated, you can simulate one of the errors by selecting the appropriate parameter.

7.5 Automatic Storage of System Parameters

Some fieldbus couplers provide the "System Parameter Handling" feature. This serves to identify changes to the configuration of a 767 Series node and to the automatic configuration of the I/O modules. When an I/O module must be replaced due to a defect, you do not need to reconfigure the new I/O module. The stored parameters are automatically transferred to the new I/O module. Detailed information on this procedure can be found in the fieldbus coupler manuals in the "Parameter Setting via FDT/DTM" section.

7.6 Updating the Firmware

When updating the module firmware, the saved module parameters can be overwritten. Therefore, check your existing configuration after updating the firmware.

8 Process Image

The size of the process image depends on the configured operating mode:

- **DO mode**
Process image when operated as a digital output module (see section "DO Mode")
- **DI mode**
Process image when operated as a digital input module (see section "DI Mode")
- **DIO mode (default)**
Process image for combined operation of digital inputs and outputs (see section "DIO Mode")
- **DIO mode + 1 counter**
Process image for combined operation of digital inputs and outputs with one counter (see section "DIO Mode + 1 Counter")
- **DIO mode + 2 counters**
Process image for combined operation of digital inputs and outputs with two counters (see section "DIO Mode + 2 Counters")

The process images for the module listed in the following sections describe the data length on the S-BUS (system bus). The implementation of the S-BUS process images onto the respective fieldbus process images can be found in the fieldbus coupler manuals.

The process image is divided into two areas: an output data area and an input data area. The process image can contain process data with and without diagnostic information, independently of whether the transmission of synchronous diagnostic information has been selected.



Note

Synchronous diagnostic information

Synchronous diagnostic information designates the cyclical transmission of diagnostic information in the process image. This is not selected in the original factory settings for the module.

This is only possible when using a fieldbus coupler that supports the synchronous diagnostic function (e.g. 767-1101 or 767-2301). Detailed information about enabling the transmission of diagnostic information can be found in the manual for the fieldbus coupler being used: see the section about the device description file.

In addition, you can also switch on synchronous diagnostic information in fieldbus couplers that support this function by using an FDT/DTM frame application (e.g. WAGOframe) in the corresponding DTM. For more information, see the Section "Parameterization via FDT/DTM" > "Diagnostics setting" in the fieldbus coupler manuals.

Note



Activate module diagnostics

You can enable or suppress the individual module diagnostics. For more information, see the Section "Diagnostics Overview".

Note



Diagnostic Actuator short circuit/overload

The "Actuator short circuit/overload" diagnostic is dependent on the switching status of the outputs (see section "Diagnostics" > "Diagnostic overview").

8.1 DO Mode

8.1.1 Input Data

The image for the process data, which are transmitted from the I/O module to the fieldbus coupler, has a size of 0 byte. If you configure synchronous diagnostic data for the I/O module, the process image has a size of 2 bytes.

The byte configuration is as follow:

Table 38: DO input data in the process image

Byte 0	7	0	Diagnostic message
			1 _B : Overtemperature on channel 1
			1 _B : Overtemperature on channel 2
			1 _B : Overtemperature on channel 3
			1 _B : Overtemperature on channel 4
			1 _B : Overtemperature on channel 5
			1 _B : Overtemperature on channel 6
			1 _B : Overtemperature on channel 7
			1 _B : Overtemperature on channel 8
Byte 1	7	0	Diagnostic message
			1 _B : Short circuit/overload field supply
			always 0
			1 _B : Undervoltage U _{LS}
			1 _B : Undervoltage U _A
			Not assigned: always 0

8.1.2 Output Data

The image for the process data, which are transmitted by the fieldbus coupler to the I/O module, has a size of 1 byte. If you configure a synchronous diagnostic confirmation of the I/O module, the process image has a size of 3 bytes.

The process data and the diagnostic confirmation are structured as follows:

Table 39: DO output data in the process image

Byte 0	7 0	Digital outputs (process data)
 1 _B : Input value = True		
Byte 1	7 0	Diagnostic confirmation
 1 _B : Overtemperature on channel 1 conf. 1 _B : Overtemperature on channel 2 conf. 1 _B : Overtemperature on channel 3 confirmed 1 _B : Overtemperature on channel 4 confirmed 1 _B : Overtemperature on channel 5 confirmed 1 _B : Overtemperature on channel 6 confirmed 1 _B : Overtemperature on channel 7 confirmed 1 _B : Overtemperature on channel 8 confirmed		
Byte 2	7 0	Diagnostic confirmation
 1 _B : Short circuit/overload field supply confirmed Not assigned 1 _B : Undervoltage U _{LS} confirmed 1 _B : Undervoltage U _A confirmed Not assigned: always 0		

8.2 DI Mode

8.2.1 Input Data

The image for the process data, which are transmitted from the I/O module to the fieldbus coupler, has a size of 1 byte. If you configure synchronous diagnostic data for the I/O module, the process image has a size of 3 bytes.

The byte configuration is as follows:

Table 40: DI input data in the process image

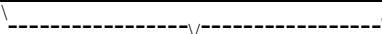
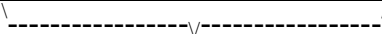
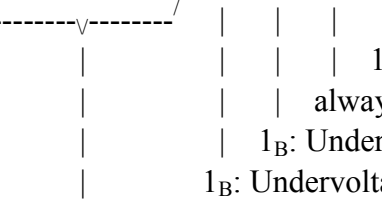
Byte 0	7 0	Digital inputs (process data)
 1_B : Input value = True		
Byte 1	7 0	Diagnostic message
 Not assigned: always 0		
Byte 2	7 0	Diagnostic message
 1_B : Short circuit/overload field supply always 0 1_B : Undervoltage U_{LS} 1_B : Undervoltage U_A Not assigned: always 0		

8.2.2 Output Data

The image for the process data, which are transmitted by the fieldbus coupler to the I/O module, has a size of 0 byte. If you configure a synchronous diagnostic confirmation of the I/O module, the process image has a size of 2 bytes.

The diagnostic confirmation is structured as follows:

Table 41: DI output data in the process image

Byte 0	7	0	Diagnostic confirmation
Not assigned: always 0			
Byte 1	7	0	Diagnostic confirmation
Not assigned: always 0			
1 _B : Short circuit/overload field supply confirmed			
Not assigned			
1 _B : Undervoltage U _{LS} confirmed			
1 _B : Undervoltage U _A confirmed			
Not assigned: always 0			

8.3 DIO Mode

8.3.1 Input Data

The image for the process data, which are transmitted from the I/O module to the fieldbus coupler, has a size of 1 byte. If you configure synchronous diagnostic data for the I/O module, the process image has a size of 3 bytes.

The byte configuration is as follows:

Table 42: DIO input data in the process image

Byte 0	7 0	Digital inputs (process data)
----- 1 _B : Input value = True State of the outputs is also displayed!		
Byte 1	7 0	Diagnostic message
 1 _B : Overtemperature on channel 1 1 _B : Overtemperature on channel 2 1 _B : Overtemperature on channel 3 1 _B : Overtemperature on channel 4 1 _B : Overtemperature on channel 5 1 _B : Overtemperature on channel 6 1 _B : Overtemperature on channel 7 1 _B : Overtemperature on channel 8		
Byte 2	7 0	Diagnostic message
----- 1 _B : Short circuit/overload field supply always 0 1 _B : Undervoltage U _{LS} 1 _B : Undervoltage U _A Not assigned: always 0		

8.3.2 Output Data

The image for the process data, which are transmitted by the fieldbus coupler to the I/O module, has a size of 1 byte. If you configure a synchronous diagnostic confirmation of the I/O module, the process image has a size of 3 bytes.

The process data and the diagnostic confirmation are structured as follows:

Table 43: DIO output data in the process image

Byte 0	7 0	Digital outputs (process data)																																																																																										
 1 _B : Input value = True																																																																																												
Byte 1	7 0	Diagnostic confirmation																																																																																										
<table style="width: 100%; border-collapse: collapse;"> <tr> <td style="width: 10%; text-align: center;"> </td> <td style="width: 10%; text-align: center;"> </td> <td style="width: 10%; text-align: center;"> </td> <td style="width: 10%; text-align: center;"> </td> <td style="width: 10%; text-align: center;"> </td> <td style="width: 10%; text-align: center;"> </td> <td style="width: 10%; text-align: center;"> </td> <td style="width: 10%; text-align: center;"> </td> <td style="width: 10%; text-align: center;"> </td> <td style="width: 10%; text-align: center;"> </td> </tr> <tr> <td></td> <td></td> <td></td> <td></td> <td></td> <td></td> <td></td> <td></td> <td></td> <td style="text-align: right;">1_B: Overtemperature on channel 1 conf.</td> </tr> <tr> <td></td> <td></td> <td></td> <td></td> <td></td> <td></td> <td></td> <td></td> <td></td> <td style="text-align: right;">1_B: Overtemperature on channel 2 confirmed</td> </tr> <tr> <td></td> <td></td> <td></td> <td></td> <td></td> <td></td> <td></td> <td></td> <td></td> <td style="text-align: right;">1_B: Overtemperature on channel 3 confirmed</td> </tr> <tr> <td></td> <td></td> <td></td> <td></td> <td></td> <td></td> <td></td> <td></td> <td></td> <td style="text-align: right;">1_B: Overtemperature on channel 4 confirmed</td> </tr> <tr> <td></td> <td></td> <td></td> <td></td> <td></td> <td></td> <td></td> <td></td> <td></td> <td style="text-align: right;">1_B: Overtemperature on channel 5 confirmed</td> </tr> <tr> <td></td> <td></td> <td></td> <td></td> <td></td> <td></td> <td></td> <td></td> <td></td> <td style="text-align: right;">1_B: Overtemperature on channel 6 confirmed</td> </tr> <tr> <td></td> <td></td> <td></td> <td></td> <td></td> <td></td> <td></td> <td></td> <td></td> <td style="text-align: right;">1_B: Overtemperature on channel 7 confirmed</td> </tr> <tr> <td></td> <td></td> <td></td> <td></td> <td></td> <td></td> <td></td> <td></td> <td></td> <td style="text-align: right;">1_B: Overtemperature on channel 8 confirmed</td> </tr> </table>																						1 _B : Overtemperature on channel 1 conf.										1 _B : Overtemperature on channel 2 confirmed										1 _B : Overtemperature on channel 3 confirmed										1 _B : Overtemperature on channel 4 confirmed										1 _B : Overtemperature on channel 5 confirmed										1 _B : Overtemperature on channel 6 confirmed										1 _B : Overtemperature on channel 7 confirmed										1 _B : Overtemperature on channel 8 confirmed
									1 _B : Overtemperature on channel 1 conf.																																																																																			
									1 _B : Overtemperature on channel 2 confirmed																																																																																			
									1 _B : Overtemperature on channel 3 confirmed																																																																																			
									1 _B : Overtemperature on channel 4 confirmed																																																																																			
									1 _B : Overtemperature on channel 5 confirmed																																																																																			
									1 _B : Overtemperature on channel 6 confirmed																																																																																			
									1 _B : Overtemperature on channel 7 confirmed																																																																																			
									1 _B : Overtemperature on channel 8 confirmed																																																																																			
Byte 2	7 0	Diagnostic confirmation																																																																																										
<table style="width: 100%; border-collapse: collapse;"> <tr> <td style="width: 10%; text-align: center;"> </td> <td style="width: 10%; text-align: center;"> </td> <td style="width: 10%; text-align: center;"> </td> <td style="width: 10%; text-align: center;"> </td> <td style="width: 10%; text-align: center;"> </td> <td style="width: 10%; text-align: center;"> </td> <td style="width: 10%; text-align: center;"> </td> <td style="width: 10%; text-align: center;"> </td> <td style="width: 10%; text-align: center;"> </td> <td style="width: 10%; text-align: center;"> </td> </tr> <tr> <td></td> <td></td> <td></td> <td></td> <td></td> <td></td> <td></td> <td></td> <td></td> <td style="text-align: right;">1_B: Short circuit/overload field supply confirmed</td> </tr> <tr> <td></td> <td></td> <td></td> <td></td> <td></td> <td></td> <td></td> <td></td> <td></td> <td style="text-align: right;">Not assigned</td> </tr> <tr> <td></td> <td></td> <td></td> <td></td> <td></td> <td></td> <td></td> <td></td> <td></td> <td style="text-align: right;">1_B: Undervoltage U_{LS} confirmed</td> </tr> <tr> <td></td> <td></td> <td></td> <td></td> <td></td> <td></td> <td></td> <td></td> <td></td> <td style="text-align: right;">1_B: Undervoltage U_A confirmed</td> </tr> <tr> <td></td> <td></td> <td></td> <td></td> <td></td> <td></td> <td></td> <td></td> <td></td> <td style="text-align: right;">Not assigned: always 0</td> </tr> </table>																						1 _B : Short circuit/overload field supply confirmed										Not assigned										1 _B : Undervoltage U _{LS} confirmed										1 _B : Undervoltage U _A confirmed										Not assigned: always 0																														
									1 _B : Short circuit/overload field supply confirmed																																																																																			
									Not assigned																																																																																			
									1 _B : Undervoltage U _{LS} confirmed																																																																																			
									1 _B : Undervoltage U _A confirmed																																																																																			
									Not assigned: always 0																																																																																			

8.4 DIO Mode + 1 Counter

8.4.1 Input Data

The image for the process data, which are transmitted from the I/O module to the fieldbus coupler, has a size of 4 bytes. If you configure synchronous diagnostic data for the I/O module, the process image has a size of 6 bytes.

The byte configuration is as follows:

Table 44: DIO + 1 counter, input data in the process image

Byte 0	7 0	Digital inputs (process data)
1 _B : Input value = True State of the outputs is also displayed!		
Byte 1	7 0	Counter status
1 _B : See section "Counter Function".		
Byte 2	15 8	Counter value
8 bits data. See section "Counter Function".		
Byte 3	7 0	Counter value
8 bits data. See section "Counter Function".		
Byte 4	7 0	Diagnostic message
 1 _B : Overtemperature on channel 1 1 _B : Overtemperature on channel 2 1 _B : Overtemperature on channel 3 1 _B : Overtemperature on channel 4 1 _B : Overtemperature on channel 5 1 _B : Overtemperature on channel 6 1 _B : Overtemperature on channel 7 1 _B : Overtemperature on channel 8		

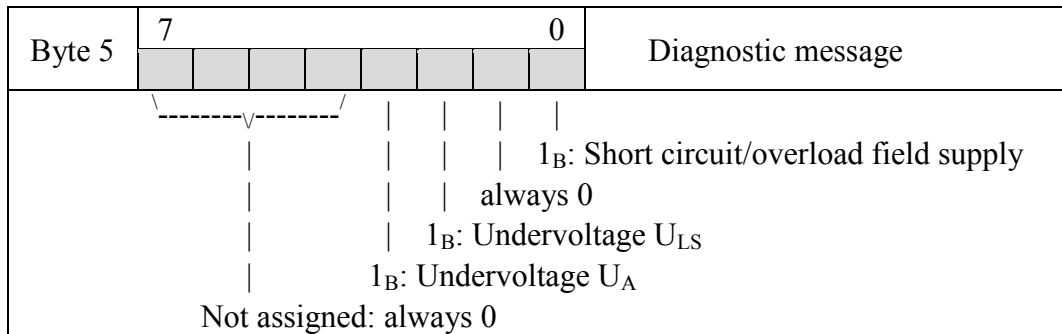

8.4.2 Output Data

The image for the process data, which are transmitted by the fieldbus coupler to the I/O module, has a size of 4 bytes. If you configure a synchronous diagnostic confirmation of the I/O module, the process image has a size of 6 bytes.

The process data and the diagnostic confirmation are structured as follows:

Table 45: DIO + 1 counter, output data in the process image

Byte 0	7 0	Digital outputs (process data)																																																																																	
1 _B : Output value = True																																																																																			
Byte 1	7 0	Counter controller																																																																																	
1 _B : See section "Counter Function".																																																																																			
Byte 2	15 8	Start value																																																																																	
8 bits data. See section "Counter Function".																																																																																			
Byte 3	7 0	Limit value																																																																																	
8 bits data. See section "Counter Function".																																																																																			
Byte 4	7 0	Diagnostic confirmation																																																																																	
<table style="width: 100%; border-collapse: collapse;"> <tr> <td style="width: 10%; border-right: 1px dashed black;"></td> <td style="width: 10%; border-right: 1px dashed black;"></td> <td style="width: 10%; border-right: 1px dashed black;"></td> <td style="width: 10%; border-right: 1px dashed black;"></td> <td style="width: 10%; border-right: 1px dashed black;"></td> <td style="width: 10%; border-right: 1px dashed black;"></td> <td style="width: 10%; border-right: 1px dashed black;"></td> <td style="width: 10%; border-right: 1px dashed black;"></td> <td style="width: 10%;"></td> </tr> <tr> <td></td> <td></td> <td></td> <td></td> <td></td> <td></td> <td></td> <td></td> <td style="text-align: right;">1_B: Overtemperature on channel 1 conf.</td> </tr> <tr> <td></td> <td></td> <td></td> <td></td> <td></td> <td></td> <td></td> <td></td> <td style="text-align: right;">1_B: Overtemperature on channel 2 conf.</td> </tr> <tr> <td></td> <td></td> <td></td> <td></td> <td></td> <td></td> <td></td> <td></td> <td style="text-align: right;">1_B: Overtemperature on channel 3 confirmed</td> </tr> <tr> <td></td> <td></td> <td></td> <td></td> <td></td> <td></td> <td></td> <td></td> <td style="text-align: right;">1_B: Overtemperature on channel 4 confirmed</td> </tr> <tr> <td></td> <td></td> <td></td> <td></td> <td></td> <td></td> <td></td> <td></td> <td style="text-align: right;">1_B: Overtemperature on channel 5 confirmed</td> </tr> <tr> <td></td> <td></td> <td></td> <td></td> <td></td> <td></td> <td></td> <td></td> <td style="text-align: right;">1_B: Overtemperature on channel 6 confirmed</td> </tr> <tr> <td></td> <td></td> <td></td> <td></td> <td></td> <td></td> <td></td> <td></td> <td style="text-align: right;">1_B: Overtemperature on channel 7 confirmed</td> </tr> <tr> <td></td> <td></td> <td></td> <td></td> <td></td> <td></td> <td></td> <td></td> <td style="text-align: right;">1_B: Overtemperature on channel 8 confirmed</td> </tr> </table>																				1 _B : Overtemperature on channel 1 conf.									1 _B : Overtemperature on channel 2 conf.									1 _B : Overtemperature on channel 3 confirmed									1 _B : Overtemperature on channel 4 confirmed									1 _B : Overtemperature on channel 5 confirmed									1 _B : Overtemperature on channel 6 confirmed									1 _B : Overtemperature on channel 7 confirmed									1 _B : Overtemperature on channel 8 confirmed
								1 _B : Overtemperature on channel 1 conf.																																																																											
								1 _B : Overtemperature on channel 2 conf.																																																																											
								1 _B : Overtemperature on channel 3 confirmed																																																																											
								1 _B : Overtemperature on channel 4 confirmed																																																																											
								1 _B : Overtemperature on channel 5 confirmed																																																																											
								1 _B : Overtemperature on channel 6 confirmed																																																																											
								1 _B : Overtemperature on channel 7 confirmed																																																																											
								1 _B : Overtemperature on channel 8 confirmed																																																																											
Byte 5	7 0	Diagnostic confirmation																																																																																	
<table style="width: 100%; border-collapse: collapse;"> <tr> <td style="width: 10%; border-right: 1px dashed black;"></td> <td style="width: 10%; border-right: 1px dashed black;"></td> <td style="width: 10%; border-right: 1px dashed black;"></td> <td style="width: 10%; border-right: 1px dashed black;"></td> <td style="width: 10%; border-right: 1px dashed black;"></td> <td style="width: 10%; border-right: 1px dashed black;"></td> <td style="width: 10%; border-right: 1px dashed black;"></td> <td style="width: 10%; border-right: 1px dashed black;"></td> <td style="width: 10%;"></td> </tr> <tr> <td></td> <td></td> <td></td> <td></td> <td></td> <td></td> <td></td> <td></td> <td style="text-align: right;">1_B: Short circuit/overload field supply confirmed</td> </tr> <tr> <td></td> <td></td> <td></td> <td></td> <td></td> <td></td> <td></td> <td></td> <td style="text-align: right;">Not assigned</td> </tr> <tr> <td></td> <td></td> <td></td> <td></td> <td></td> <td></td> <td></td> <td></td> <td style="text-align: right;">1_B: Undervoltage U_{LS} confirmed</td> </tr> <tr> <td></td> <td></td> <td></td> <td></td> <td></td> <td></td> <td></td> <td></td> <td style="text-align: right;">1_B: Undervoltage U_A confirmed</td> </tr> <tr> <td></td> <td></td> <td></td> <td></td> <td></td> <td></td> <td></td> <td></td> <td style="text-align: right;">Not assigned: always 0</td> </tr> </table>																				1 _B : Short circuit/overload field supply confirmed									Not assigned									1 _B : Undervoltage U _{LS} confirmed									1 _B : Undervoltage U _A confirmed									Not assigned: always 0																											
								1 _B : Short circuit/overload field supply confirmed																																																																											
								Not assigned																																																																											
								1 _B : Undervoltage U _{LS} confirmed																																																																											
								1 _B : Undervoltage U _A confirmed																																																																											
								Not assigned: always 0																																																																											

8.5 DIO Mode + 2 Counters

8.5.1 Input Data

The image for the process data, which is transmitted from the I/O module to the fieldbus coupler, has a size of 6 bytes. If you configure synchronous diagnostic data for the I/O module, the process image has a size of 8 bytes.

The byte configuration is as follows:

Table 46: DIO + 2 counters, input data in the process image

Byte 0	7 [][][][][][][][] 0	Digital inputs (process data)
1 _B : Input value = True State of the outputs is also displayed.		
Byte 1	7 [][][][][][][][] 0	Counter status
1 _B : See section "Counter Function".		
Byte 2	15 [][][][][][][][][][][][][][][] 8	Counter value 1
8 bits data. See section "Counter Function".		
Byte 3	7 [][][][][][][][] 0	Counter value 1
8 bits data. See section "Counter Function".		
Byte 4	15 [][][][][][][][][][][][][][][] 8	Counter value 2
8 bits data. See section "Counter Function".		
Byte 5	7 [][][][][][][][] 0	Counter value 2
8 bits data. See section "Counter Function".		

Byte 6	7								Diagnostic message
 1 _B : Overtemperature on channel 1 1 _B : Overtemperature on channel 2 1 _B : Overtemperature on channel 3 1 _B : Overtemperature on channel 4 1 _B : Overtemperature on channel 5 1 _B : Overtemperature on channel 6 1 _B : Overtemperature on channel 7 1 _B : Overtemperature on channel 8									
Byte 7	7								Diagnostic message
 1 _B : Short circuit/overload field supply always 0 1 _B : Undervoltage U _{LS} 1 _B : Undervoltage U _A Not assigned: always 0									

8.5.2 Output Data

The image for the process data, which are transmitted by the fieldbus coupler to the I/O module, has a size of 4 bytes. If you configure a synchronous diagnostic confirmation of the I/O module, the process image has a size of 6 bytes.

The process data and the diagnostic confirmation are structured as follows:

Table 47: DIO + 2 counters, output data in the process image

Byte 0	7 0	Digital outputs (process data)																																																																																										
1 _B : Output value = True																																																																																												
Byte 1	7 0	Counter controller																																																																																										
1 _B : See section "Counter Function".																																																																																												
Byte 2	15 8	Start value																																																																																										
8 bits data. See section "Counter Function".																																																																																												
Byte 3	7 0	Limit value																																																																																										
8 bits data. See section "Counter Function".																																																																																												
Byte 4	7 0	Diagnostic confirmation																																																																																										
<table style="width: 100%; border-collapse: collapse;"> <tr> <td style="width: 10%;"></td> <td style="width: 10%;"></td> <td style="width: 10%;"></td> <td style="width: 10%;"></td> <td style="width: 10%;"></td> <td style="width: 10%;"></td> <td style="width: 10%;"></td> <td style="width: 10%;"></td> <td style="width: 10%;"></td> <td style="width: 10%;"></td> </tr> <tr> <td></td> <td></td> <td></td> <td></td> <td></td> <td></td> <td></td> <td></td> <td></td> <td>1_B: Overtemperature on channel 1 conf.</td> </tr> <tr> <td></td> <td></td> <td></td> <td></td> <td></td> <td></td> <td></td> <td></td> <td></td> <td>1_B: Overtemperature on channel 2 conf.</td> </tr> <tr> <td></td> <td></td> <td></td> <td></td> <td></td> <td></td> <td></td> <td></td> <td></td> <td>1_B: Overtemperature on channel 3 confirmed</td> </tr> <tr> <td></td> <td></td> <td></td> <td></td> <td></td> <td></td> <td></td> <td></td> <td></td> <td>1_B: Overtemperature on channel 4 confirmed</td> </tr> <tr> <td></td> <td></td> <td></td> <td></td> <td></td> <td></td> <td></td> <td></td> <td></td> <td>1_B: Overtemperature on channel 5 confirmed</td> </tr> <tr> <td></td> <td></td> <td></td> <td></td> <td></td> <td></td> <td></td> <td></td> <td></td> <td>1_B: Overtemperature on channel 6 confirmed</td> </tr> <tr> <td></td> <td></td> <td></td> <td></td> <td></td> <td></td> <td></td> <td></td> <td></td> <td>1_B: Overtemperature on channel 7 confirmed</td> </tr> <tr> <td></td> <td></td> <td></td> <td></td> <td></td> <td></td> <td></td> <td></td> <td></td> <td>1_B: Overtemperature on channel 8 confirmed</td> </tr> </table>																						1 _B : Overtemperature on channel 1 conf.										1 _B : Overtemperature on channel 2 conf.										1 _B : Overtemperature on channel 3 confirmed										1 _B : Overtemperature on channel 4 confirmed										1 _B : Overtemperature on channel 5 confirmed										1 _B : Overtemperature on channel 6 confirmed										1 _B : Overtemperature on channel 7 confirmed										1 _B : Overtemperature on channel 8 confirmed
									1 _B : Overtemperature on channel 1 conf.																																																																																			
									1 _B : Overtemperature on channel 2 conf.																																																																																			
									1 _B : Overtemperature on channel 3 confirmed																																																																																			
									1 _B : Overtemperature on channel 4 confirmed																																																																																			
									1 _B : Overtemperature on channel 5 confirmed																																																																																			
									1 _B : Overtemperature on channel 6 confirmed																																																																																			
									1 _B : Overtemperature on channel 7 confirmed																																																																																			
									1 _B : Overtemperature on channel 8 confirmed																																																																																			
Byte 5	7 0	Diagnostic confirmation																																																																																										
<table style="width: 100%; border-collapse: collapse;"> <tr> <td style="width: 10%;"></td> <td style="width: 10%;"></td> <td style="width: 10%;"></td> <td style="width: 10%;"></td> <td style="width: 10%;"></td> <td style="width: 10%;"></td> <td style="width: 10%;"></td> <td style="width: 10%;"></td> <td style="width: 10%;"></td> <td style="width: 10%;"></td> </tr> <tr> <td></td> <td></td> <td></td> <td></td> <td></td> <td></td> <td></td> <td></td> <td></td> <td>1_B: Short circuit/overload field supply confirmed</td> </tr> <tr> <td></td> <td></td> <td></td> <td></td> <td></td> <td></td> <td></td> <td></td> <td></td> <td>Not assigned</td> </tr> <tr> <td></td> <td></td> <td></td> <td></td> <td></td> <td></td> <td></td> <td></td> <td></td> <td>1_B: Undervoltage U_{LS} confirmed</td> </tr> <tr> <td></td> <td></td> <td></td> <td></td> <td></td> <td></td> <td></td> <td></td> <td></td> <td>1_B: Undervoltage U_A confirmed</td> </tr> <tr> <td></td> <td></td> <td></td> <td></td> <td></td> <td></td> <td></td> <td></td> <td></td> <td>Not assigned: always 0</td> </tr> </table>																						1 _B : Short circuit/overload field supply confirmed										Not assigned										1 _B : Undervoltage U _{LS} confirmed										1 _B : Undervoltage U _A confirmed										Not assigned: always 0																														
									1 _B : Short circuit/overload field supply confirmed																																																																																			
									Not assigned																																																																																			
									1 _B : Undervoltage U _{LS} confirmed																																																																																			
									1 _B : Undervoltage U _A confirmed																																																																																			
									Not assigned: always 0																																																																																			

9 Counter Function

The module also makes available two counters independent of one another, which can be controlled both via the physical connections X1 ... X4 (channels 1 ...4) of the module as well as via the process data (control and status byte).

Each counter has a counter input (impulse input), two configurable control inputs (gate input, count direction), as well as a configurable switching output, which is set automatically by the module upon reaching a limit value. This way, quick reaction times can be achieved, which are not dependent on the fieldbus and the controller.

Note



Default

The gate function is activated in the control byte by default. This bit must be enabled to use the counter functions (see section “Control Byte”).

The counting takes place edge-controlled; that is, the counter status is incremented or decremented when there is a change of the signal on the impulse input from 0 V to 24 V, depending on the configuration of the counter as an up or down counter.

There are three operating modes available for the counter:

- **Event counter**
This counts the impulses detected on the impulse input.
- **Gate time counter**
It counts the impulses within a definable gate time (time window in which the measurement takes place). For the gate time of 1 s, you get the frequency of the input signal in Hz. The gate time counter can be configured via the process data.
- **Pulse duration counter**
This counts the pulse duration in ms.

If the channels are assigned to a counter, you can still configure all available adjustable channel properties (e.g. inversion or filtering).

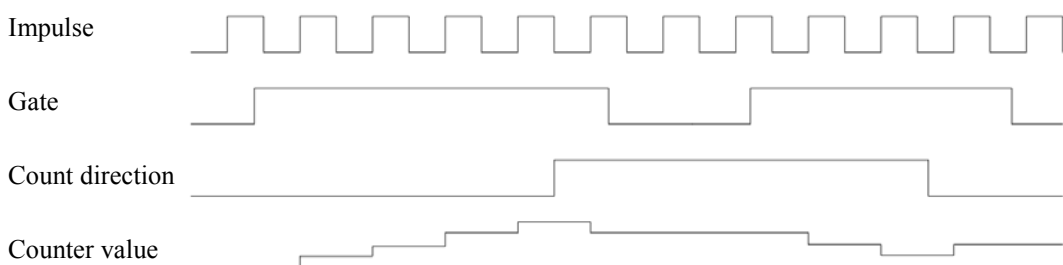

Figure 20: Counter status depending on the control inputs (gate and count direction input)

9.1 Control of the Counter via Inputs and Outputs

The counter functions (counter) are assigned the sensor and actuator connections (X1 ... X4) as follows:

- Counter 1
connections X1, X2 (channels 1 ... 4)
- Counter 2
connections X3, X4 (channels 5 ... 8)

The assignment of the counter functions to the individual channels is defined in the following table. By default, the functions "gate input," "count direction input," and "switching output" are deactivated via the inputs and outputs. They then control the counter via the process data (see section "Control and Monitoring of the Counter via the Process Data").

In order to control the counter functions via the inputs and outputs of the module, switch these on via DTMs using WAGOframe or another FDT/DTM framework application. You can find the necessary DTMs at wago.com. This configuration is also possible with some fieldbus systems (e.g. PROFIBUS→GSD).

Table 48: Connection assignment for the counter function

Inputs and outputs	Connector	Description
Counter 1: impulse input	X1	Counter input
Counter 1: gate input	X2	Release input: 0: Counter is blocked. Impulses will not be counted. 1: Counter is released. Impulses will be counted.
Counter 1: count direction input	X3	0: Counter counts up. 1: Counter counts downwards.
Counter 1: switching output	X4	Counts up: On reaching the set limit value, the output is set. Counts down: On exceeding the limit value 0, the output is set.
Counter 2: impulse input	X5	See counter 1
Counter 2: gate input	X6	
Counter 2: count direction	X7	
Counter 2: switching output	X8	

For detailed information about connection assignment, see section "Connect Sensor/Actuator Cable".

9.2.2 Status Byte

The counter status is output via the status byte in the process image, which is defined as follows:

Table 50: Status byte

7							0	Status byte counter 1, 2
							Gate status: counter 1 0 _B : inactive 1 _B : active	
							Count direction: counter 1 0 _B : up counter 1 _B : down counter	
							Limit value status: counter 1 0 _B : limit value not set 1 _B : limit value set	
							Counter 2 (see bits 0 ... 2)	
							Reserved	
							Control mode counter 1 and 2 0 _B : control mode deactivated 1 _B : control mode activated	

9.2.3 Example of Controlling Two Counters via the Process Data

Prerequisite:

For the module in DTM, you have set the operating mode "DIO module + 2 counters." For control of the counter via the output data, the parameter "Simulation" must also be deactivated for the counter.

For the following example, heed the descriptions of the control byte (section "Control Byte").

To control the counter via the process data (output data), the control mode (set bit 7) must be activated. In this mode, the counter is stopped. Only with a set control mode can you set the other bits individually or simultaneously. To check the configuration, the control mode bit of the status byte is then read via the process data (input data). When setting the start or limit value, the value must remain in the output process image after resetting the control mode (at least one cycle).

The control mode bit must be reset and then set again before configuring the second counter.

Table 51: Example of controlling two counters via control byte

Binary	Hexadecimal	Description
10010010	92	Counter 1: Set limit value and gate function for counter release.
0xxxxxxx	0	Both counters are released
10000110	86	Counter 1: Set count direction "down" and gate function for counter release. Both counters are released
0xxxxxxx	0	Both counters are released
11000011	C3	Counter 2: Set both start value and gate function for counter release.
0xxxxxxx	0	Both counters are released

10 Diagnostics

10.1 LED Signaling

The following table lists the operating messages that are indicated via LEDs. Information regarding remedies of certain causes is also provided.

Note



Disabling specific diagnostics

Use the diagnostic overview (section "Parameterizing" > "Diagnostic Overview") to disable specific diagnostics (see F- and I/O-LED). In this case, the corresponding LED is disabled (off).

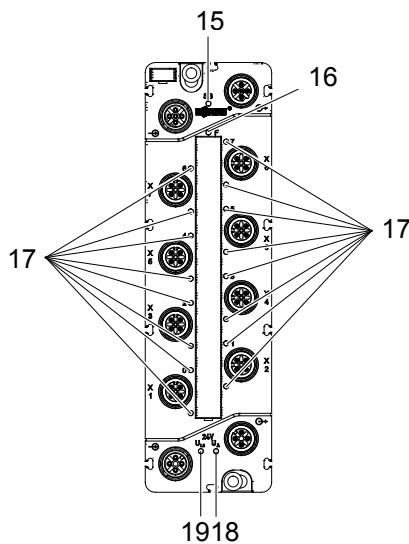

Figure 21: LEDs indicating operational messages (exemplary)

Table 52: Operating messages 1

Pos.	LED	Color/Status	Cause	Remedy/information
15	SB	Off	Low voltage; U_{LS} not available.	Check the power supply.
		Red, flashing, 4 Hz	S-BUS error on module.	Check whether the S-BUS cable is connected. Check the S-BUS cable for damages. Check whether the fieldbus coupler firmware is compatible with the module.
		Red, flashing, 1 or 2 Hz	The module is being restarted via the fieldbus coupler.	If the flashing frequency is 1Hz, please contact WAGO Support.
		Green	Data exchange is in process; process data values are valid. The module is in RUN mode.	-

Table 52: Operating messages 1

Pos.	LED	Color/Status	Cause	Remedy/information
15	SB	Green and orange, flashing, 1 Hz	The set substitute value is applied to the module.	Can be set by the fieldbus coupler if fieldbus is missing. Check the fieldbus connection and the status of the higher-level controller.
		Orange, flashing, 2 Hz	The module has detected the S-BUS.	-
		Orange and green, flashing, 4 Hz	The last module is being detected in the 767 node.	Check the S-BUS terminator and/or the S-BUS cables.
		Orange, flashing, 1 Hz	The fieldbus coupler is addressing the module in the 767 node.	-
		Orange and green, flashing, 2 Hz	The S-BUS parameters are being stored by the fieldbus coupler.	-
		Orange	The firmware is being updated.	All 767 Series components are being updated by the fieldbus coupler within the node.
		Orange, flashing, 4 Hz	The module is attempting to establish communication with the fieldbus coupler.	Check the power supply to upstream 767 Series component and/or check the S-BUS cable for damages.
15	SB	Green, flashing, 1 Hz	The module is in HOLD mode.	Is initiated by the fieldbus coupler. In DI mode, the last input values transferred to the fieldbus coupler are kept in the process image. In DO mode, the last output values are retained.
		Green, flashing, 2 Hz	The module is in STOP mode.	Is initiated by the fieldbus coupler. In DI mode, the input values are set to 0 in the process image. In DO mode, the output value is output as 0.

Table 53: Operating messages 2

Pos.	LED	Color/Status	Cause	Remedy/information
16	F	Red	There is at least one global diagnostic message on the module.	Check the supply voltages U_{LS} and U_A of the upstream 767 components. For more information, see the section "Parameterizing"> "Diagnostic Overview".
17	I/O	Yellow	Input or output signal pending.	-
		Red*	Error on output.	Check the actuator connection for short circuit/overload. A short circuit or overload can only be diagnosed if the output is switched on.
		* If you set the time of the parameter "Restart delay, actuator" (section "Parameterizing"> "Parameters of outputs") to 0 ms, the I/O LED appears yellow rather than red in case of a short circuit or overload due to the short restart interval.		
18	U_A	Green	Actuator supply U_A is present.	-
		Off	Actuator supply U_A is not present.	Connect the power supply and check the voltage level, if applicable.
19	U_{LS}	Green	Logic supply and sensor supply U_{LS} are present.	-
		Off	Logic supply and sensor supply U_{LS} are not present.	Connect the power supply and check the voltage level, if applicable.

11 Service

This section contains information on maintenance and service.

11.1 Updating the Firmware

The firmware for the module can be updated. This takes place via the USB connection of a fieldbus coupler. Additional information can be found in the fieldbus manuals in section "Updating the Firmware".

11.2 Replacing the Module

To replace a module, e.g., to change variants, proceed as described follow.

11.2.1 Disconnecting the Cables

Before removing the connectors, clean the module to ensure that no dirt or other material comes in contact with the connections. This can lead to damage of the contacts.

To unplug the cables, proceed as follows:

1. Disconnect the power supply from those devices on which you have mounted the module.



CAUTION

Hot connection sockets!

Even when taking into account derating, high surface temperatures on the metallic connection sockets and on the enclosure can arise during operation. If the 767 Series component has been in operation, allow it to cool off before moving it.

2. Unscrew all screw connections and remove the cables.

11.2.2 Removing the Module from Your System

To remove the module from your system's framework, proceed as follows:

1. Disconnect the power supply from those devices on which you have mounted the module.
2. Release the module from your system by unscrewing the M4 screws.

11.2.3 Removing the Module from the Carrier Rail

In order to keep the representation unambiguous, the carrier rail adapter in the following figure (B, C) is shown without module.

If the module is mounted on a carrier rail, proceed with the removal as follows:

1. Disconnect the power supply from those devices on which you have mounted the module.
2. To remove the module, press down the release actuator of the carrier rail adapter using a slot screwdriver (B) and remove it from the carrier rail (C).

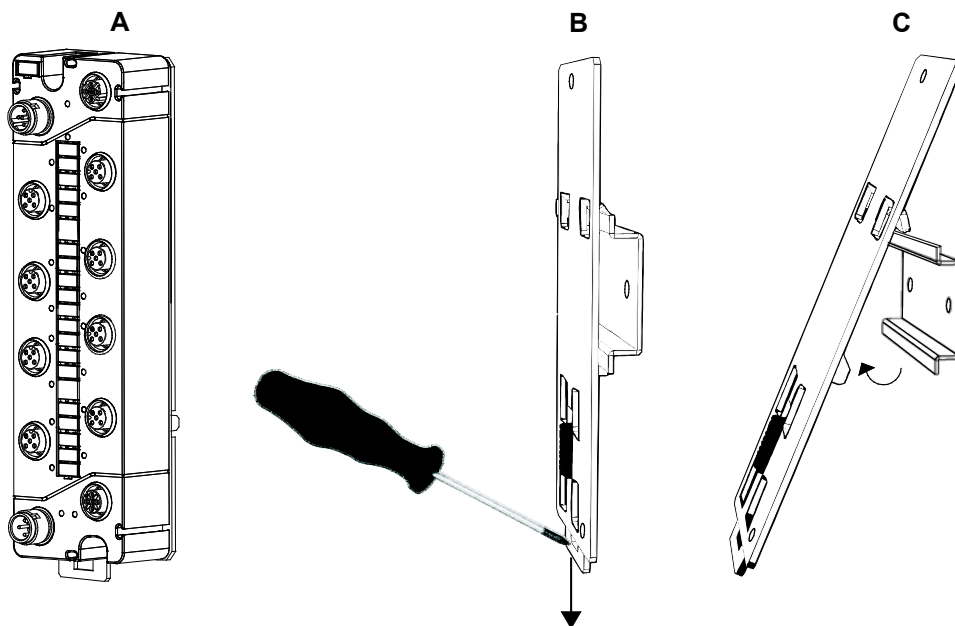

Figure 22: Removing the module (with the carrier rail adapter) from the carrier rail

11.2.4 Removing the Module from the Profile Adapter

If the module is mounted on a profile adapter, proceed with the removal as follows:

1. Disconnect the power supply from that part of the system on which you have mounted the module before attempting to remove it.
2. Unscrew the screws on which the nuts are fastened and remove the module from the profile rail of your system.
3. Unscrew the screws that connect the module with the profile adapter.

11.2.5 Connecting the Module

To connect the module, proceed as described in Sections 4 through 6. If necessary, the parameters of the previous module are transferred to the new module, depending on the type of fieldbus coupler being used. For more information, see section "Parameterizing" > "Automatic Storage of System Parameters".

11.3 Disposal

Do not dispose of the 767 Series components in the household waste; observe the laws which apply to them. You can also contact a certified waste management company.

12 Use of the Interference-Free Module in Safety Applications

Due to its interference-free feature, this module is suitable for passive use in safety circuits.

If the field side supply is shut down via a safety switching device, the safety function of the module is not active. When the interference-free module is used correctly in a safety-related application, neither the SIL or Performance Level achieved by the circuit nor the Category will be influenced. This requires that you adhere to the following notes and connection diagrams:

12.1 Important Notes

NOTICE

Only use SELV/PELV power supplies!

Only a power supply unit with protective extra-low voltage (SELV/PELV) shall be used for the 24V power supply.

NOTICE

Prevent short circuits to external voltages on the digital outputs!

A short circuit of a digital output to external voltages (e.g. 24V field voltage supplies) leads to backward infeed of the field voltage and loss of the safety function. To eliminate the possibility of an error, connecting cables between the outputs of the interference-free modules and the actuators must be laid protected in accordance with EN 60204-1 or EN ISO 13849-2.

NOTICE

Short circuits between two digital outputs!

The safety switching device does not recognize a short circuit between two digital outputs of interference-free modules. The two-channel shutdown based on interference-free module is no safety function, but is only used to functionally shut down actuators.

12.2 General Measures and Conditions for the Power Supply Solution of the Module

WARNING

Prevent conductive pollution!

Conductive pollution in the connection sockets of the power supply connections for voltages UA and ULS can be prevented through suitable measures. Before establishing the connection, inspect the contact areas for dirt and debris. Only use clean tools and materials when handling the modules.

WARNING

Tighten connectors with torque!

To achieve protection class IP67, the connectors must be tightened at a torque of 0.6 Nm. Otherwise, the safe shutdown of the I/O module by a safety switching device in the case of penetrating pollution cannot be ensured.

WARNING

Observe connecting cable specification!

The values indicated in the specification for the connecting cables regarding the environmental characteristics and mechanical load capacity must never be exceeded.

WARNING

Use safety switching device with diagnostic functions!

The safety switching device must have diagnostic functions, which ensure detection of the external power supply, so that an accumulation of errors does not lead to loss of the safety function.

WARNING

When connecting the wire ends to the connectors, prevent the strands from fraying!

If a prefabricated cable from WAGO is not used, then prevent the strands of the wire ends from fraying when connecting the cable to the connectors. A short circuit in the connector can otherwise lead to loss of the safety function. If necessary, check the insulation of the wires to each other using a high-voltage test, for example.

 **WARNING**

Protect supply voltages using an external fuse!

Both supply voltages U_A and U_{LS} must be protected using a suitable external fuse to ensure that the current flow remains uninterrupted in case of error. U_A and U_{LS} can each be protected using a safety fuse according to EN 60127-2 or electronic fuse, e.g. WAGO 787-861. Safety fuses according to EN 60127-2 must meet the following technical requirements:

- G fuse link (e.g. WAGO Order No. 282-122)
 - Rated current 4 A
 - Time lag
 - Surge resistant
 - Large or increased breaking capacity
 - Rated voltage ≥ 60 V DC
 - Time-current characteristic: 275 % from rated current corresponding to 11 A maximum 80 s
-

12.3 Measures and Conditions for Shielded Power Supply of the Module

⚠ WARNING

Shielded version of U_A and $0 V_{U_A}$ in connecting lead for unprotected installation required!

To prevent a short circuit of power supply U_A with an external voltage, wires U_A and $0 V_{U_A}$ must be shielded in the connecting lead according to EN 60204-1 or EN ISO 13849-2. The shield must have an overlap of at least 85 % and be reliably connected to the connector.

⚠ WARNING

Attach ground shield or use insulation monitoring!

The connecting lead ground shield and functional grounding connection of the interference-free modules must be connected to lines $0 V_{U_{LS}}$ and $0 V_{U_A}$. In addition, insulation monitoring according to EN 61557 can also be used. See the following illustrations:

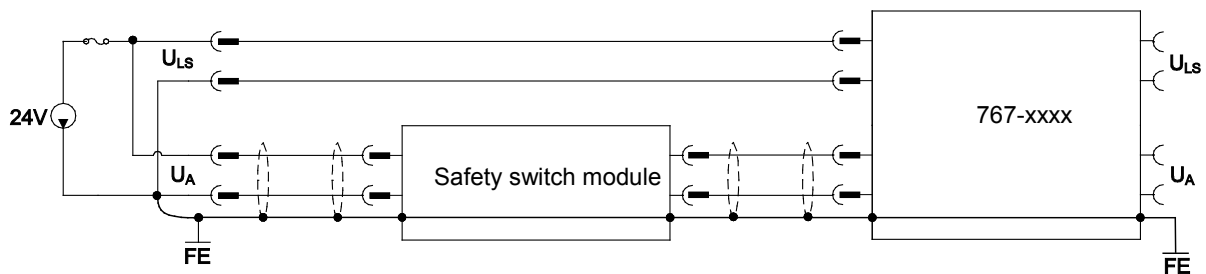

Figure 23: Connection diagram for the common power supply

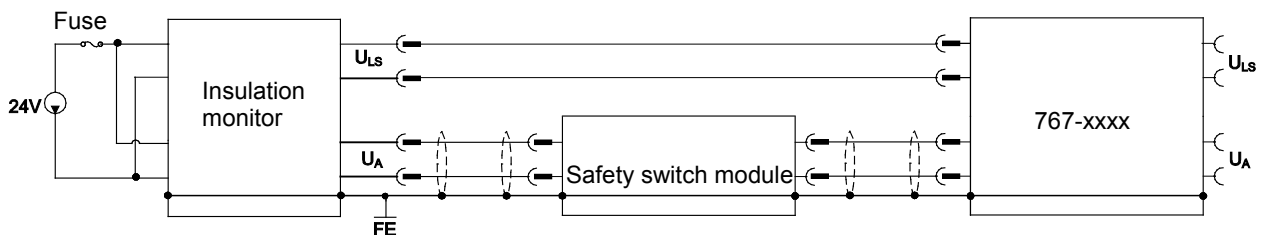

Figure 24: Connection diagram for the common power supply with insulation monitoring

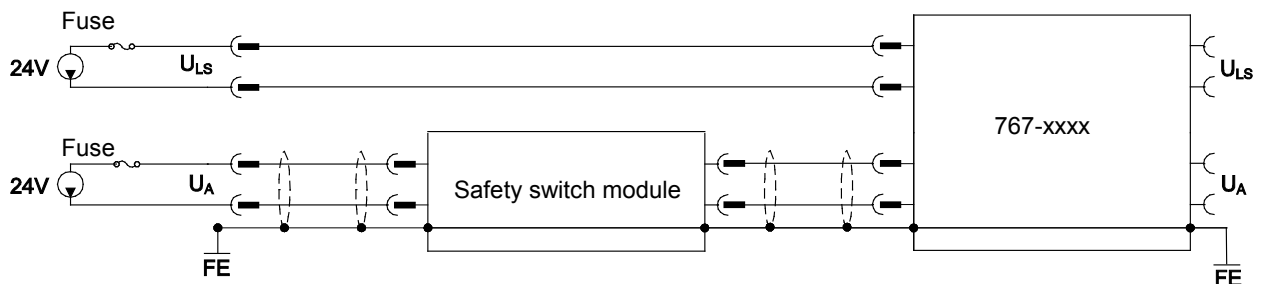

Figure 25: Connection diagram for the isolated power supply

12.4 Measures and Conditions for Unshielded Power Supply of the Module

WARNING

Measures when using connecting cables with no shielding!

If you use unshielded connecting cables to supply interference-free modules, you are required to install the connecting cables according to EN 60204-1 or EN ISO 13849-2 in a cable duct, armored conduit or shielded installation space. The measures must be suitable to ensure fault exclusion (short circuit between any two conductors) according to EN 60204-1 or EN ISO 13849-2. The fault exclusion must apply to supply voltages U_A and external voltages (e.g. U_{LS}). Please also note the cable routing in the outlet area of the protective measure (e.g. outlet area from the armored conduit/cable duct).

12.5 Connection of the Module to Safety Switching Devices

12.5.1 General Structure of a Potential Group

When using the interference-free module in safety-related applications, you must combine the interference-free modules belonging to one safety switching device in a potential group. The power supply U_A of the interference-free module may only be connected to the digital output of a suitable safety switching device (24 V).

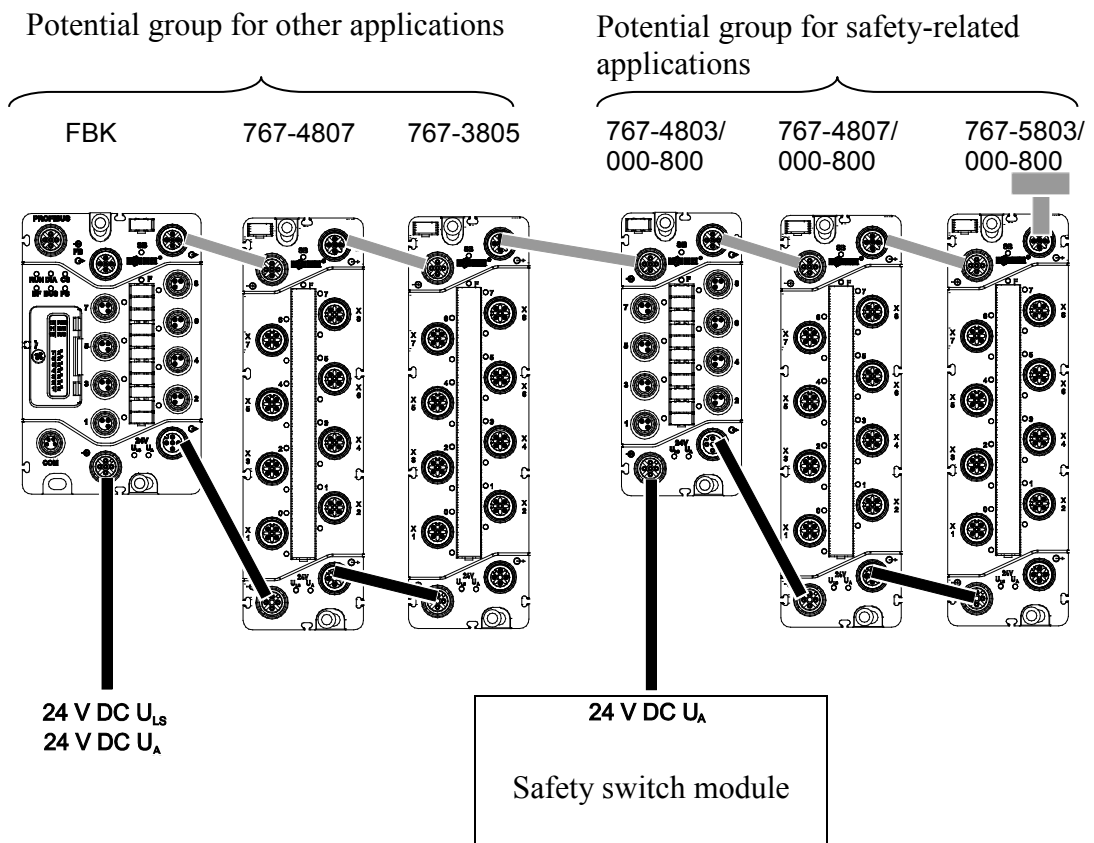

Figure 26: Example structure of potential groups

12.5.2 Examples of Connection

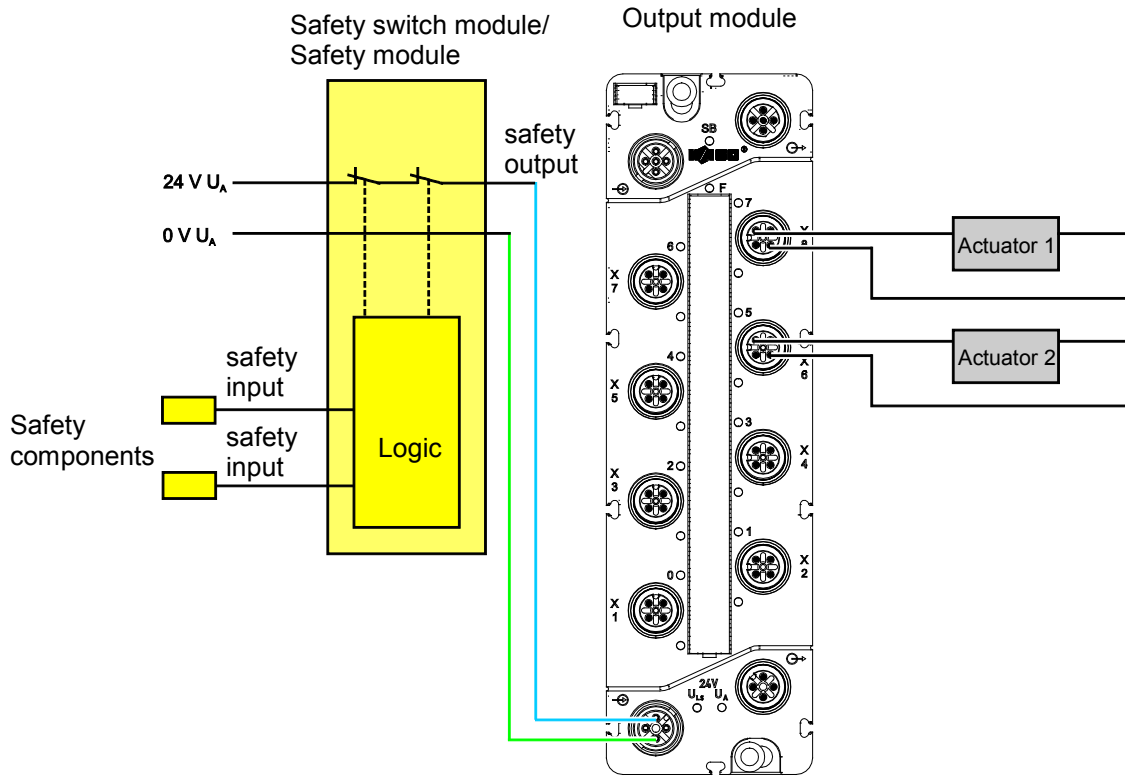

Figure 27: Single pin shutdown of the power supply of all digital outputs

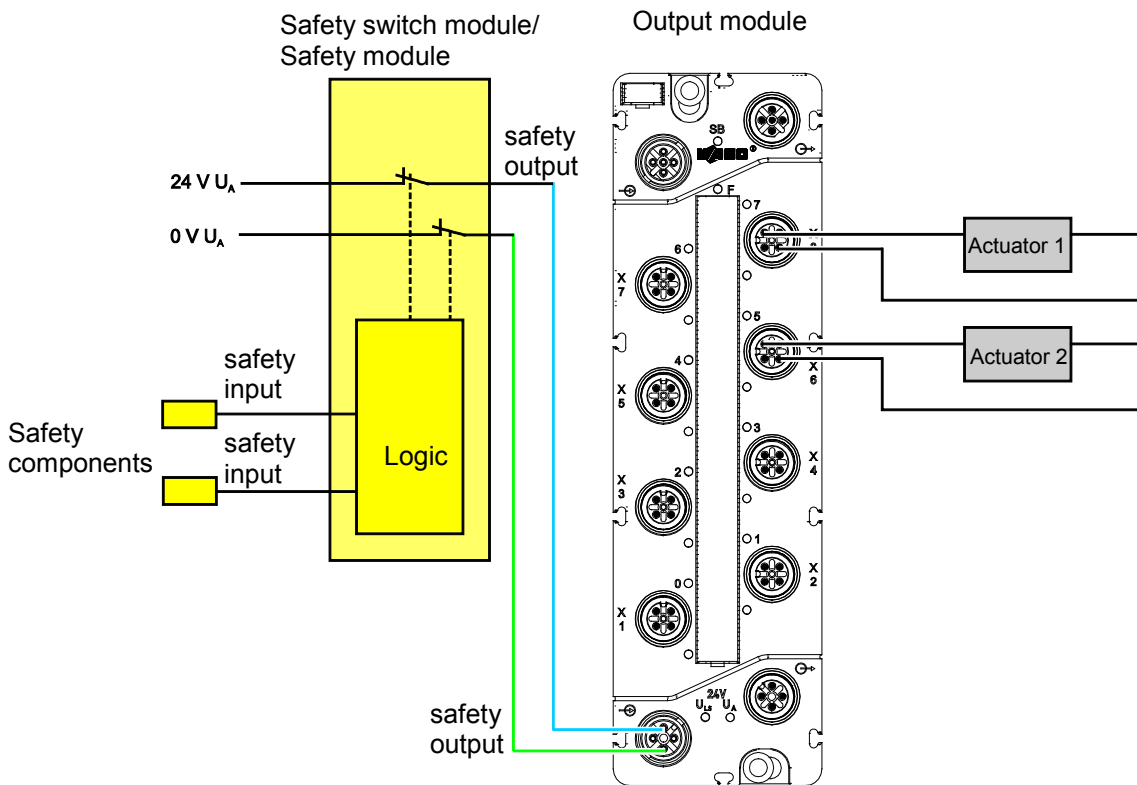

Figure 28: Two-pin shutdown of the power supply of all digital outputs

13 Appendix

13.1 Diagnostic Information

Some fieldbus couplers display the error code in the form of an attribute path (CIA), through which diagnostics are clearly assigned. Other fieldbus couplers (e.g., PROFINET I/O or PROFIBUS DP) convert the attribute path into a fieldbus-specific message.

The following diagnostic codes can be generated by the module:

Table 54: Diagnostics of the module

Diagnostic Message	Attribute Path			Classification
	C	I	A	
Short circuit/overload field supply (This function is only active when the field supply is switched on.)	16	1	128	Diagnostic alarm
Low voltage of U_{LS} (sensor supply)	50	1	128	Diagnostic alarm
Low voltage of U_A (actuator supply)	50	1	129	Diagnostic alarm

Table 55: Diagnostics of the individual channels of the module

Diagnostic Message	Attribute Path			Classification
	C	I	A	
Overtemperature (This function is only enabled when the actuator output is switched on.)	9	Channel No.	128	Diagnostic alarm

Use the "Diagnostic Overview" to disable specific diagnostics.

List of Figures

Figure 1: Connectors	17
Figure 2: Marking possibilities and fastening (exemplary).....	18
Figure 3: Display elements (exemplary)	19
Figure 4: Labeling (example).....	20
Figure 5: Label on the module	21
Figure 6: Schematic diagram.....	22
Figure 7: Dimensions of the module in millimeters (exemplary)	23
Figure 8: Mounting the module on the grounded system.....	36
Figure 9: Fastening to the carrier rail adapter	37
Figure 10: Mounting the carrier rail adapter (exemplary).....	38
Figure 11: Fastening to the profile adapter	39
Figure 12: Replacing the marking spaces.....	41
Figure 13: Attaching a spacer to a module.....	42
Figure 14: Attaching another module with a spacer.....	43
Figure 15: S-BUS connected to a fieldbus coupler and modules.....	47
Figure 16: Supply cable connected to a fieldbus coupler and modules	49
Figure 17: Connectors (exemplary).....	51
Figure 18: Example of an open DTM, including parameters.....	54
Figure 19: Example of the diagnostic overview of a module (information may differ from the actual module).....	56
Figure 20: Counter status depending on the control inputs (gate and count direction input).....	80
Figure 21: LEDs indicating operational messages (exemplary)	85
Figure 22: Removing the module (with the carrier rail adapter) from the carrier rail	89
Figure 23: Connection diagram for the common power supply.....	94
Figure 24: Connection diagram for the common power supply with insulation monitoring.....	94
Figure 25: Connection diagram for the isolated power supply	94
Figure 26: Example structure of potential groups	96
Figure 27: Single pin shutdown of the power supply of all digital outputs	97
Figure 28: Two-pin shutdown of the power supply of all digital outputs.....	97

List of Tables

Table 1: Number Notation.....	9
Table 2: Font Conventions	9
Table 3: Legend for figure "Connectors"	17
Table 4: Legend for figure "Marking possibilities and fastening"	18
Table 5: Legend for figure "Display elements"	19
Table 6: Legend for figure "Labeling"	20
Table 7: Description of manufacturing number	21
Table 8: Technical Data – General Information.....	24
Table 9: Technical data – Supply	24
Table 10: Technical data – Communication.....	24
Table 11: Technical data – Inputs	25
Table 12: Technical data – Input Characteristic.....	26
Table 13: Technical data – Outputs.....	26
Table 14: Technical data – Information on actuator selection	27
Table 15: Technical data – Operating state influence on output.....	27
Table 16: Technical data – Counter 1 and 2 (configurable).....	28
Table 17: Technical data – Configurable Functions	28
Table 18: Technical data – Configurable functions for counters	29
Table 19: Technical data – Diagnostics	30
Table 20: Technical Data – Process Image	30
Table 21: Technical Data – Indicators	30
Table 22: Technical data – Isolation	30
Table 23: S-BUS connection assignment.....	46
Table 24: Supply connection assignment.....	48
Table 25: Digital inputs/outputs: connection assignment	50
Table 26: Counter: Assignment of channels for connection assignment	50
Table 27: DTM buttons	54
Table 28: Information on the module.....	55
Table 29: Diagnostics setup	56
Table 30: Information about existing module diagnostics	57
Table 31: Information about existing channel diagnostics.....	57
Table 32: Overview of operating modes	58
Table 33: Overview of adjustable parameters for the digital outputs	59
Table 34: Overview of adjustable parameters for the digital inputs	61
Table 35: Overview of adjustable counter parameters for the DIO Module.....	62
Table 36: Overview of parameters for the entire module	64
Table 37: Overview of adjustable parameters for the field supply	64
Table 38: DO input data in the process image	68
Table 39: DO output data in the process image	69
Table 40: DI input data in the process image.....	70
Table 41: DI output data in the process image.....	71
Table 42: DIO input data in the process image.....	72
Table 43: DIO output data in the process image.....	73
Table 44: DIO + 1 counter, input data in the process image.....	74
Table 45: DIO + 1 counter, output data in the process image.....	76
Table 46: DIO + 2 counters, input data in the process image	77
Table 47: DIO + 2 counters, output data in the process image	79
Table 48: Connection assignment for the counter function	81

Table 49: Control byte.....	82
Table 50: Status byte	83
Table 51: Example of controlling two counters via control byte	84
Table 52: Operating messages 1	85
Table 53: Operating messages 2.....	87
Table 54: Diagnostics of the module.....	98
Table 55: Diagnostics of the individual channels of the module	98

WE! INNOVATE!

WAGO Kontakttechnik GmbH & Co. KG
Postfach 2880 • D-32385 Minden
Hansastraße 27 • D-32423 Minden
Phone: 05 71/8 87 – 0
Fax: 05 71/8 87 – 1 69
E-Mail: info@wago.com
Internet: <http://www.wago.com>

