

WAGO-SPEEDWAY 767

Manual



767-6403

4 AI TC

Analog Input Module for Thermocouples (TCs)

Version 3.1.0

© 2016 by WAGO Kontakttechnik GmbH & Co. KG
All rights reserved.

WAGO Kontakttechnik GmbH & Co. KG

Hansastraße 27
D-32423 Minden

Phone: +49 (0) 571/8 87 – 0
Fax: +49 (0) 571/8 87 – 1 69

E-Mail: info@wago.com

Web: <http://www.wago.com>

Technical Support

Phone: +49 (0) 571/8 87 – 5 55
Fax: +49 (0) 571/8 87 – 85 55

E-Mail: support@wago.com

Every conceivable measure has been taken to ensure the accuracy and completeness of this documentation. However, as errors can never be fully excluded, we always appreciate any information or suggestions for improving the documentation.

E-Mail: documentation@wago.com

We wish to point out that the software and hardware terms as well as the trademarks of companies used and/or mentioned in the present manual are generally protected by trademark or patent.

Table of Contents

1	Notes about this Documentation.....	6
1.1	Validity of these Operating Instructions	6
1.2	Copyright.....	6
1.3	Symbols.....	7
1.4	Number Notation.....	9
1.5	Font Conventions	9
2	Important Notes	10
2.1	Legal Bases	10
2.1.1	Subject to Changes	10
2.1.2	Personnel Qualification	10
2.1.3	Use in Compliance with Underlying Provisions	11
2.1.4	Technical Condition of Specified Devices	11
2.2	Safety Advice (Precautions).....	12
2.3	Safety Equipment	13
2.4	Notes on Operation	14
3	Device Description	15
3.1	Connectors.....	16
3.2	Marking Possibilities and Fastening	17
3.3	Display Elements	18
3.4	Labeling.....	19
3.5	Schematic Diagram	21
3.6	Dimensions.....	22
3.7	Technical Data	23
3.7.1	General Information	23
3.7.2	Supply.....	23
3.7.3	Communication	23
3.7.4	Inputs	24
3.7.5	Analog Value Creation	24
3.7.6	Failures and Errors	25
3.7.7	Configurable Functions	25
3.7.8	Diagnostics	25
3.7.9	Process Image.....	25
3.7.10	Display Elements.....	26
3.7.11	Isolation	26
3.8	Approvals	27
3.9	Standards and Guidelines	28
4	Mounting.....	29
4.1	Information on Mounting.....	29
4.2	Tools and Accessories Required for Mounting.....	31
4.3	Direct Mounting on Your System	32
4.4	Mounting on a Carrier Rail (only with WAGO Accessories).....	33
4.4.1	Fastening the Carrier Rail Adapter to the Module	33
4.4.2	Fastening the Module with Carrier Rail Adapter to a Carrier Rail	34
4.5	Mounting on a Profile Rail (only with WAGO Accessories)	35
4.5.1	Fastening the Profile Adapter to the Module	35

4.5.2	Fastening the Module with Profile Adapter to a Profile Rail	36
4.6	Marking and Replacing the Marking Spaces	37
4.7	Mounting the Spacer in the Case of Compact Arrangement.....	38
5	Connecting Data and Supply Cables.....	40
5.1	Notes	40
5.2	Required Accessories	41
5.3	Connecting the S-BUS Cables	42
5.4	Connecting the Supply Cable.....	44
5.5	Connect the Sensor Cable	46
6	Commissioning	48
7	Parameterizing	49
7.1	Electronic Type Label	51
7.2	Diagnostic Overview.....	52
7.3	Input Parameters.....	54
7.4	User-defined Measuring Range 1 – 4.....	56
7.5	Global Settings	58
7.6	Automatic Storage of System Parameters.....	59
7.7	Updating the Firmware	59
8	Process Image	60
8.1	Input Data.....	61
8.2	Output Data	63
9	Diagnostics	64
9.1	LED Signaling.....	64
10	Service	67
10.1	Updating the Firmware	67
10.2	Replacing the Module	67
10.2.1	Disconnecting the Cables	67
10.2.2	Removing the Module from Your System	68
10.2.3	Removing the Module from the Carrier Rail	68
10.2.4	Removing the Module from the Profile Adapter.....	69
10.2.5	Connecting the Module	69
10.3	Disposal.....	69
11	Use in Hazardous Environments	70
11.1	Marking Configuration Examples.....	71
11.1.1	Marking for Europe According to ATEX and IEC-Ex	71
11.2	Installation Regulations.....	72
11.2.1	Special Conditions for Safe Use (ATEX Certificate BVS 15 ATEX E098X).....	73
11.2.2	Special Conditions for Safe Use (IEC Ex Certificate IECEx BVS 15.0083X).....	74
12	Appendix.....	75
12.1	Measuring Ranges/Process Value Ranges	75
12.2	Diagnostic Information	78
	List of Figures	79

List of Tables..... 80

1 Notes about this Documentation

The module shall only be installed and operated in conjunction with these operating instructions and the system description.

WARNING

Observe release notes!

Please note that, within the SPEEDWAY system, a function is provided **without restriction** only if all system's components have the same system-wide firmware release. Therefore, always observe the appropriate release notes on products used.

NOTICE

Supply layout!

In addition to these operating instructions, you will need the “WAGO *SPEEDWAY 767*, System Description and Information” manual, which can be downloaded at www.wago.com. There you will find information regarding supply layout, etc.

Note



Always retain this documentation!

This documentation is part of the product. Therefore, retain the documentation during the entire service life of the product. Pass on the documentation to any subsequent user. In addition, ensure that any supplement to this documentation is included, if necessary.

1.1 Validity of these Operating Instructions

These operating instructions are only applicable to the WAGO *SPEEDWAY 767* Series module 4 AI TC, 767-6403.

1.2 Copyright

This Manual, including all figures and illustrations, is copyright-protected. Any further use of this Manual by third parties that violate pertinent copyright provisions is prohibited. Reproduction, translation, electronic and phototechnical filing/archiving (e.g., photocopying) as well as any amendments require the written consent of WAGO Kontakttechnik GmbH & Co. KG, Minden, Germany. Non-observance will involve the right to assert damage claims.

1.3 Symbols

 **DANGER**

Personal Injury!

Indicates a high-risk, imminently hazardous situation which, if not avoided, will result in death or serious injury.

 **DANGER**

Personal Injury Caused by Electric Current!

Indicates a high-risk, imminently hazardous situation which, if not avoided, will result in death or serious injury.

 **WARNING**

Personal Injury!

Indicates a moderate-risk, potentially hazardous situation which, if not avoided, could result in death or serious injury.

 **CAUTION**

Personal Injury!

Indicates a low-risk, potentially hazardous situation which, if not avoided, may result in minor or moderate injury.

NOTICE

Damage to Property!

Indicates a potentially hazardous situation which, if not avoided, may result in damage to property.

NOTICE

Damage to Property Caused by Electrostatic Discharge (ESD)!

Indicates a potentially hazardous situation which, if not avoided, may result in damage to property.

Note

Important Note!

Indicates a potential malfunction which, if not avoided, however, will not result in damage to property.

Information



Additional Information:

Refers to additional information which is not an integral part of this documentation (e.g., the Internet).

1.4 Number Notation

Table 1: Number Notation

Number Code	Example	Note
Decimal	100	Normal notation
Hexadecimal	0x64	C notation
Binary	'100' '0110.0100'	In quotation marks, nibble separated with dots (.)

1.5 Font Conventions

Table 2: Font Conventions

Font Type	Indicates
<i>italic</i>	Names of paths and data files are marked in italic-type. e.g.: <i>C:\Program Files\WAGO Software</i>
Menu	Menu items are marked in bold letters. e.g.: Save
>	A greater-than sign between two names means the selection of a menu item from a menu. e.g.: File > New
Input	Designation of input or optional fields are marked in bold letters, e.g.: Start of measurement range
“Value”	Input or selective values are marked in inverted commas. e.g.: Enter the value “4 mA” under Start of measurement range .
[Button]	Pushbuttons in dialog boxes are marked with bold letters in square brackets. e.g.: [Input]
[Key]	Keys are marked with bold letters in square brackets. e.g.: [F5]

2 Important Notes

This section includes an overall summary of the most important safety requirements and notes that are mentioned in each individual section. To protect your health and prevent damage to devices as well, it is imperative to read and carefully follow the safety guidelines.

2.1 Legal Bases

2.1.1 Subject to Changes

WAGO Kontakttechnik GmbH & Co. KG reserves the right to provide for any alterations or modifications that serve to increase the efficiency of technical progress. WAGO Kontakttechnik GmbH & Co. KG owns all rights arising from the granting of patents or from the legal protection of utility patents. Third-party products are always mentioned without any reference to patent rights. Thus, the existence of such rights cannot be excluded.

2.1.2 Personnel Qualification

All sequences implemented on the module may only be carried out by electrical specialists with sufficient knowledge in automation. The specialists must be familiar with the current standards and guidelines for the module and automation environment.

2.1.3 Use in Compliance with Underlying Provisions

The module 767-6403 is used to connect and analyze the measured values from thermocouples and voltage sensors. The module computes the voltage corresponding to the measured resistor and transmits the data to a higher-level controller (e.g., a programmable fieldbus coupler).

The module may not be used to control safety-related functions, i.e. it cannot be a functional part of a safety function.

The module may only be operated in combination with components of the WAGO *SPEEDWAY 767* Series.

The module was developed for applications requiring IP 67 (NEMA type 6, 6P) protection.

Applications other than those described in this manual are not permitted.

2.1.4 Technical Condition of Specified Devices

The devices to be supplied ex works are equipped with hardware and software configurations, which meet the individual application requirements. WAGO Kontakttechnik GmbH & Co. KG will be exempted from any liability in case of changes in hardware or software as well as to non-compliant usage of devices.

Please send your request for modified and new hardware or software configurations directly to WAGO Kontakttechnik GmbH & Co. KG.

2.2 Safety Advice (Precautions)

DANGER



Electric voltage!

Operate the 767 Series components exclusively with 24 VDC PELV (Protective Extra Low Voltage) or SELV (Safety Extra Low Voltage) voltage sources. Failure to comply may result in electric shock.

CAUTION



Hot connection sockets!

Even when taking into account derating, high surface temperatures on the metallic connection sockets and on the enclosure can arise during operation. If the 767 Series component has been in operation, allow it to cool off before moving it.

NOTICE

The highest current carrying capacity of the supply contacts is 4 A!

Always observe the maximum current carrying capacity per supply line (U_{LS} , U_A) for each 767 Series component and the overall power consumption for all 767 components. Neither of these values shall exceed 4 A since an increase in current causes the contacts to overheat and damages the 767 Series components. Information regarding the power demand of each 767 Series component can be found in the corresponding data sheet, which is available from www.wago.com.

NOTICE

Exposed connections!

If connections have not been closed with protective caps, liquid or dirt can penetrate the components of the 767 Series module and ruin it. Therefore, close all unnecessary connections with protective caps, which must be ordered separately, in order to maintain the IP67 degree of protection. (See section “Accessories” of the fieldbus coupler/controller manual.)

- Disconnect the power supply from the system on which you wish to mount the 767 Series device.
- Observe the appropriate accident prevention regulations for your system during assembly, start-up, maintenance, and repairs. For example, BGV A3, “Electrical systems and equipment”.
- The operating instructions for the 767 Series module and the system description must be laid out ready on site.
- Observe the exact positioning (coding) between plug and socket.
- The 767 Series device shall not come into contact with substances having seeping and insulating properties. Otherwise, additional measures shall be

taken for the device, such as installation of an enclosure that is resistant to the above-mentioned substance properties.

- Electronic components fulfilling the ESD requirements according to the IEC 61000-6-2 are integrated in the 767 device. As higher voltages may occur, under unfavorable circumstances, due to electrical charge in the field, discharge must be ensured before performing work on the 767 system.
- Ensure that the potential equalization is correctly laid out.
- Keep all cables a sufficient distance away from electromagnetic sources of interference in order to maintain a high level of interference resistance of the 767 system against electromagnetic emissions. Use only shielded cables at the necessary locations, and always observe the appropriate standards for EMC-suitable installations.
- For the power supply and for the S-BUS, use only pre-assembled WAGO system cables, so the specified characteristics of the technical data can be achieved.
- Replace defective or damaged modules (e.g., deformed connections), else function disruptions can occur in the respective fieldbus stations or nodes.
- When laying any cables, make sure that you do not lay them within the shear range of movable machine parts.
- For each activity, observe the corresponding personnel qualification in the corresponding section.
- Observe the marking on the front and rear side of the module.

2.3 Safety Equipment

All 767 Series products are designed to meet the requirements of IP67. This includes complete protection against accidental contact with electrical voltage and currents – even when wet.

2.4 Notes on Operation

When integrating the 767 module in your machine or system, all the currently applicable norms, regulations and guidelines shall be observed during all activities: for example, BGV A3, “Electrical systems and equipment”, DIN EN 418, EN 60204. The emergency stop equipment shall remain effective in all operating modes of the system and machine.

For protection from electromagnetic interferences

- Connect your system to protective earth (PE), and
- Ensure that the cable routing and the installation of the fieldbus cable, S-BUS cable, supply cable, and sensor or actuator cable are correct.

The following elements for 24 V supply shall be present:

- Outer lightning protection on buildings
- Inner lightning protection of supply lines and signal lines
- Safe electrical separation of low voltage 24 VDC through PELV (Protective Extra Low Voltage) or SELV (Safety Extra Low Voltage) voltage sources

3 Device Description

The module 767-6403 is used to connect thermocouples. The module has many parameterization options that can be carried out via a fieldbus coupler. In addition, the module is used for measuring small voltages (up to 290 mV).

Measuring ranges of the module:

- **Supported thermo couples**
Type B, Type C, Type E, Type J, Type K, Type N, Type R, Type S, Type T
- **Voltage measuring range** $\pm 36 \dots \pm 290$ mV

Use a fieldbus or FDT-DTM as, for example, with the WAGOframe to make module settings. Detailed information about assignment of module parameters using a fieldbus can be found in the corresponding manual.

Detailed information regarding the properties of the module is available in Section "Technical Data".

3.1 Connectors

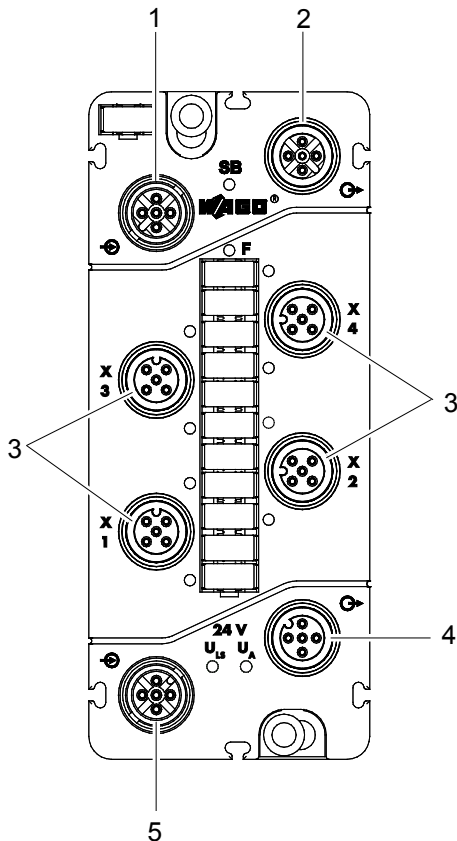

Figure 1: Connectors

Table 3: Legend for figure "Connectors"

Position	Description	Function
1	S-BUS input M12 plug, B-coded	For transmitting data from previous 767 Series components.
2	S-BUS output M12 socket, B-coded	For transmitting S-BUS data to the next 767 Series components or to the S-BUS terminator.
3	Analog inputs X1 – X4 M12 socket, A-coded	For connecting analog sensors.
4	Supply output M12 socket, A-coded	To use the Logic-/Sensor-supply and/or actuator supply for the following I/O modules.
5	Supply input M12 plug, A-coded	For feeding in both U_{LS} (logic and sensor supply) and U_A (actuator supply).

3.2 Marking Possibilities and Fastening

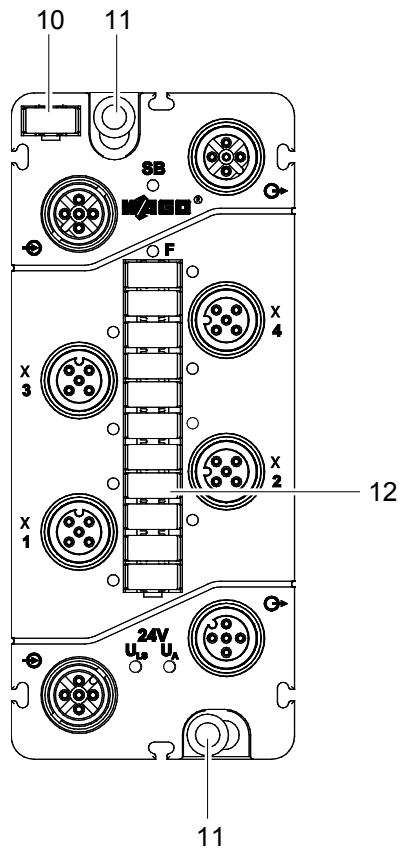

Figure 2: Marking possibilities and fastening (exemplary)

Table 4: Legend for figure "Marking possibilities and fastening"

Position	Description	Function
10	Module marker card	For identifying the module within a fieldbus node.
11	Mounting holes	With integrated function earth (FE) socket for fastening and grounding the module.
12	Marker strips	For identifying inputs.

3.3 Display Elements

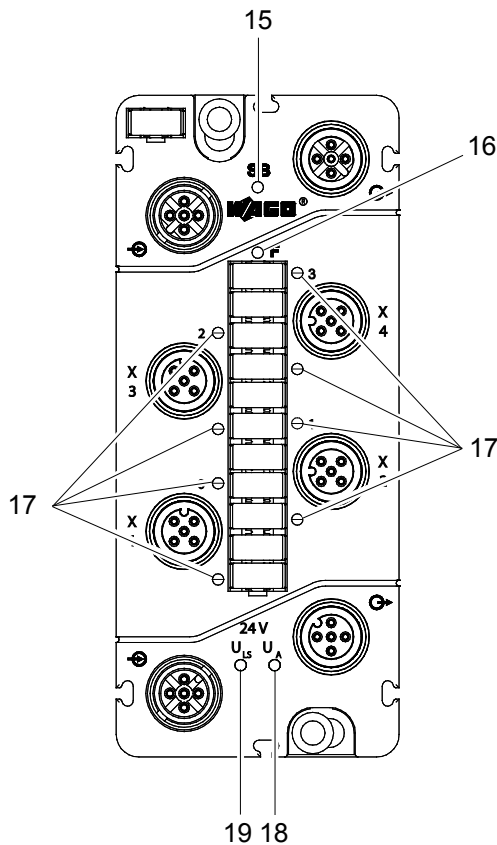

Figure 3: Display elements (exemplary)

Table 5: Legend for figure "Display elements"

Position	LED	Color	Meaning
15	SB	Green/red/orange	S-BUS status
16	F	Red	Diagnostic information
17	Ch1 – Ch4	Yellow	Indication of input status
	Er1 – Er4	Red	Indication of input error
18	U _A	Green	Actuator supply is present.
19	U _{LS}	Green	Logic supply and sensor supply are present.

Note



Detailed information

Detailed information can be found in section "Diagnostics" > "LED Signaling".

3.4 Labeling

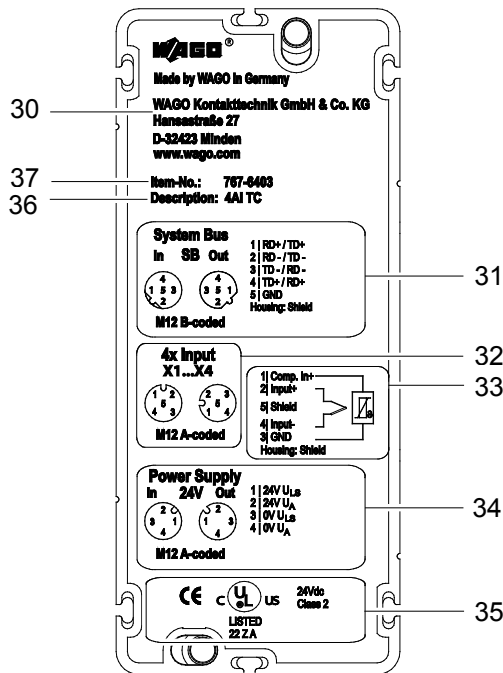

Figure 4: Labeling

Table 6: Legend for figure "Labeling"

Position	Description
30	Manufacturer's mailing address
31	Connection assignment of S-BUS
32	Connection assignment of inputs
33	Connection example
34	Connection assignment of supply input and output
35	Information on approvals and CE marks
36	Unambiguous identification of module
37	Item number

On the side of the module is a label, with information that would prove useful in the case of a complaint:

- BA: Work order number (40)
- SN: Serial number (40)
- Manufacturing number (41)

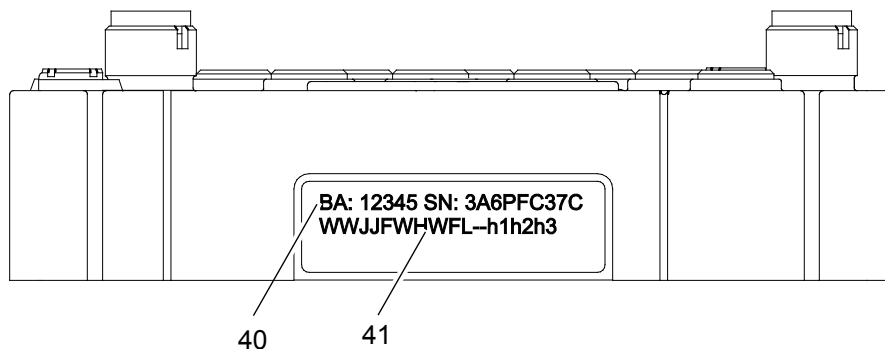

Figure 5: Label on the module

Table 7: Description of manufacturing number

Abbreviation	Description
WW	Week of production
JJ	Year of production
FW	Firmware release index When updating the firmware, please note that, the firmware release index may not be conformed to the printed firmware release index on the side of the fieldbus coupler. The “Electronic Type Label” (see section “Electronic Type Label”) shows the actual firmware release index.
HW	Hardware release index
FL	Firmware loader release index
h1h2h3	Internal manufacturer information

3.5 Schematic Diagram

The following schematic diagram provides an overview of the power supply and principle of operation of the power supply connections, as well as the analog inputs of the modules (see also sections "Connecting Data and Supply Cables" > "Connecting the Supply Cable" and "Connecting the Sensor Cable").

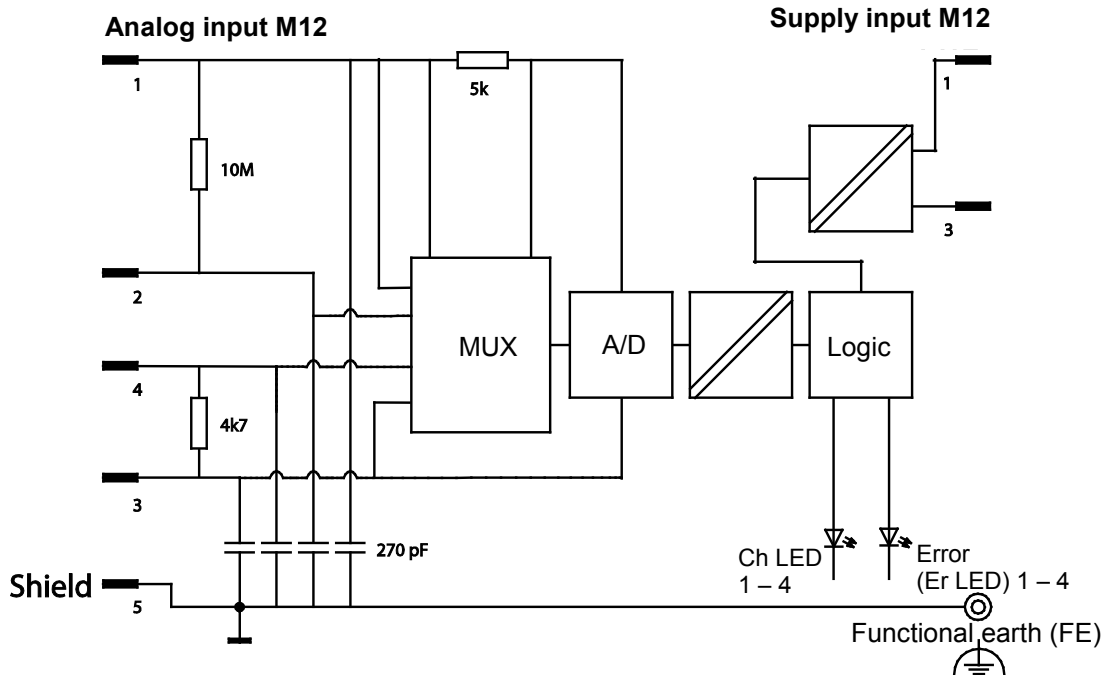

Figure 6: Schematic diagram

3.6 Dimensions

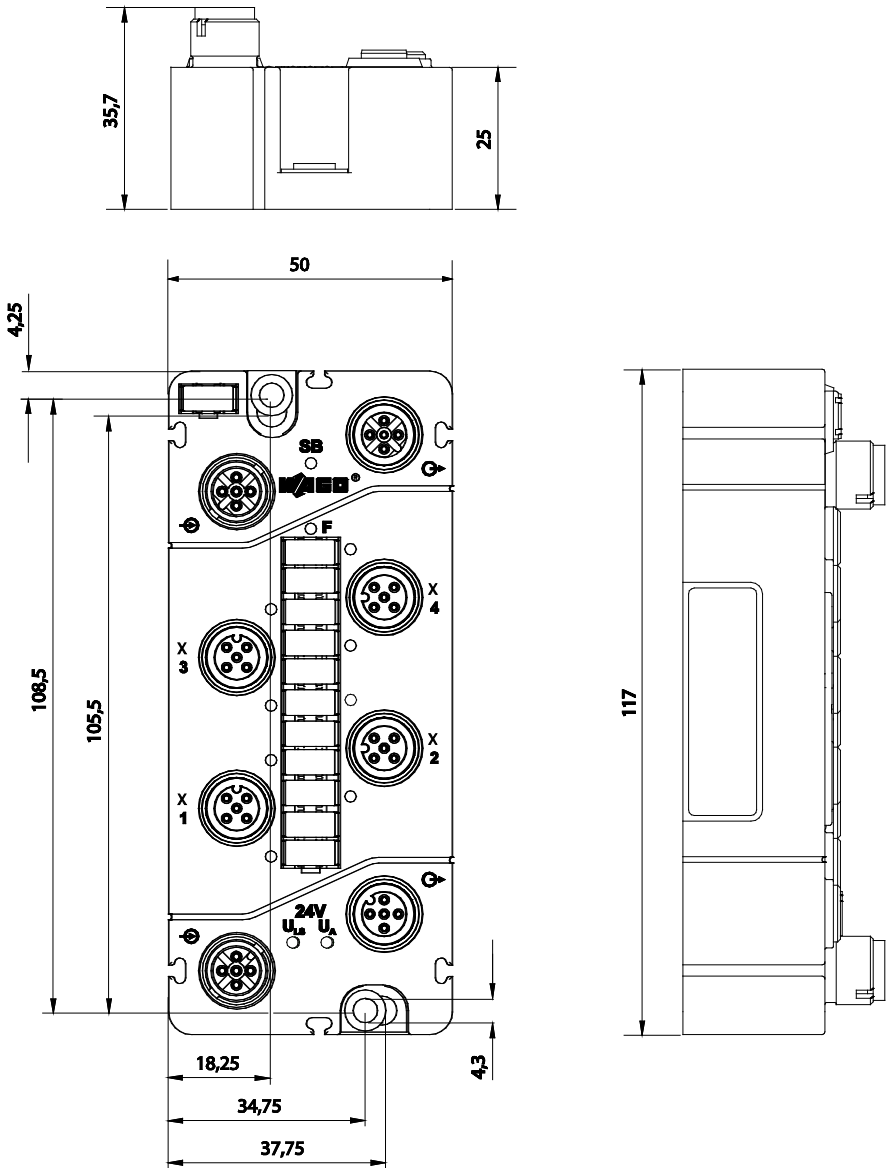

Figure 7: Dimensions of the module in millimeters (exemplary)

3.7 Technical Data



Note

Different technical data for applications in hazardous areas!

If the device is used in an application in the hazardous area, the technical data contained in the ATEX/IECEx certificate are binding in this application!

3.7.1 General Information

Table 8: Technical data – General information

Width	50 mm
Height	35.7 mm
Lowness	117 mm
Weight	Approx. 262 g

3.7.2 Supply

Table 9: Technical data – Supply

Connection type	M12 connectors, A coded, 4 poles*
Current carrying capacity of the supply connections	Maximum 8 A (U_{LS} : 4 A, U_A : 4 A)
Supply voltage	
Logic and sensor voltage U_{LS}	DC 24 V (-25 % ... +30 %)
Actuator voltage U_A **	DC 24 V (-25 % ... +30 %)
Supply current	
Logic and sensor current I_{LS}	Typically 40 mA
Actuator current I_A	≤ 5 mA
Protection	Reverse voltage protection for $U_{LS} + U_A$

* Derating must be observed

** Also required for supply transmission

3.7.3 Communication

Table 10: Technical data – Communication

S-BUS connection	Shielded M12 connector, B-coded, 5 poles
------------------	--

3.7.4 Inputs

Table 11: Technical data – Inputs

Number of inputs	4
Connection type	M12 connectors, A coded, 5 poles
Type of signal	Thermocouples voltage and extra low voltage, Option: Pt1000 resistance measurement
Wire connection	2-wire (shielded)
Signal measuring range Thermocouples Voltage	Depending on sensor type $\pm 36 \dots \pm 290 \text{ mV}$
Measuring range	Type B: $+200 \text{ }^\circ\text{C} \dots +1.820 \text{ }^\circ\text{C}$ Type C: $0 \text{ }^\circ\text{C} \dots +2.320 \text{ }^\circ\text{C}$ Type E: $-250 \text{ }^\circ\text{C} \dots +1.000 \text{ }^\circ\text{C}$ Type J: $-210 \text{ }^\circ\text{C} \dots +1.200 \text{ }^\circ\text{C}$ Type K: $-210 \text{ }^\circ\text{C} \dots +1.370 \text{ }^\circ\text{C}$ Type N: $-210 \text{ }^\circ\text{C} \dots +1.300 \text{ }^\circ\text{C}$ Type R: $-50 \text{ }^\circ\text{C} \dots +1.768 \text{ }^\circ\text{C}$ Type S: $-50 \text{ }^\circ\text{C} \dots +1.768 \text{ }^\circ\text{C}$ Type T: $-210 \text{ }^\circ\text{C} \dots +400 \text{ }^\circ\text{C}$
Resolution	0.1 $^\circ\text{C}$ 0.01 mV or higher
Measuring current	$< 0.35 \text{ mA}$ (for cold junction compensation)
Type of cable, cable length	Shielded, $\leq 30 \text{ m}$
Wrong connection of inputs	No effect

3.7.5 Analog Value Creation

Table 12: Technical data – Analog value creation

Resolution	16 bits
Integration Time	2 ... 120 ms
Method of conversion	Sigma delta
Monotonicity without error code	Yes
Conversion time	Integration Time x 3
Sampling repeat time	Number of active channels x conversion time

3.7.6 Failures and Errors

Table 13: Technical data – Failures and errors

Max. measuring error (without cold junction compensation)	$\leq \pm 1$ K over entire measuring range (for Type K)
Max. measuring error of cold junction compensation	$\leq \pm 1$ K
Temperature error	± 0.05 K/K (for Type K)
Maximum error over the full temperature range	± 3 K

3.7.7 Configurable Functions

Table 14: Technical data – Configurable functions

Measuring range (per channel)	B, C, E, J, K, N, R, S, T ± 36 , ± 72 , ± 145 , ± 290 mV user-defined
Cold junction compensation (per channel)	Type: Fixed temperature; Compensation connector on actual input; Compensation connector on previous input; Temperature: Value Offset: Value
Limiting values (per channel)	Min/Max
Integration time (per channel)	2/4/8/16.7/20/30/60/120 ms
Linearization (per channel)	Linear, Type B, Type C, Type E, Type J, Type K, Type N, Type R, Type S, Type T
Substitute value (per channel)	Value
Online simulation per channel per channel/module	Lock/unlock; simulation value: (according to measuring range) diagnostics

3.7.8 Diagnostics

Table 15: Technical data – Diagnostics

Per channel	Overrange/underflow measuring range
Per channel	Limit value violation (min/max)
Per module	Wire break
Per module	Undervoltage ($U_{LS} + U_A$)

3.7.9 Process Image

Table 16: Technical data – Process image

Process data width	8 data bytes + status
--------------------	-----------------------

3.7.10 Display Elements

Table 17: Technical data – Display elements

SB: S-BUS status	LED (green/red/orange)
F: Input error status	LED (red)
Ch1 ... Ch4 : Input signal status	LED (yellow)
Er1 ... Er4 : Input signal error	LED (red)
$U_{LS} + U_A$: Supply status	LED (green)
Indicators	Non-retentive

3.7.11 Isolation

Table 18: Technical data – Isolation

Channel - Channel	No
U_{LS} , U_A , S-bus	500 VDC each

3.8 Approvals

The following approvals have been granted to 767-6403 module:

 Conformity Marking

 cUL_{us} UL508

The following Ex approvals are pending for 767-6403 module:



BVS 15 ATEX E098X

II 3 G Ex nA IIC T5 Gc

II 3 D Ex tc IIIB T90°C Dc

IECEX BVS 15.0083X

Ex nA IIC T5 Gc

Ex tc IIIB T90°C Dc

3.9 Standards and Guidelines

The module 767-6403 meets the following standards and guidelines:

EC EMC Directive	2004/108/EC
EMC CE-Immunity to interference	acc. to EN 61000-6-2
EMC CE-Emission of interference	acc. to EN 61000-6-4
Ex Directive	94/9/EC
Explosive atmosphere Devices – General requirements	EN 60079-0
Explosive atmosphere Equipment protection by type of protection "n"	EN 60079-15
Explosive atmosphere Equipment dust ignition protection by enclosure "t"	EN 60079-31
Explosive atmospheres General requirements	IEC 60079-0
Explosive atmospheres Equipment protection by type of protection "n"	IEC 60079-15
Explosive atmospheres Equipment dust ignition protection by enclosure "t"	IEC 60079-31

4 Mounting

The module can be fastened directly to your system using screws. It can also be mounted on a carrier rail using an adapter or fastened to a profile rail using a surface mounting profile.

For mounting on a flat surface, WAGO offers spacers to assist in the mounting process that can be inserted between the 767 Series components. This helps by providing sufficient mounting distance for compact direct mounting, as well as eliminating gaps where dirt could accumulate. A cable tie can be fastened through each of two mounts in the spacer, which together serve to relieve strain from the sensor or actuator cables.

4.1 Information on Mounting

The following information shall always be observed:

- Disconnect the power supply from the system before you start with installation.
- The maximum diameter of the drill hole of the module's mounting holes is not to exceed 4 mm. Otherwise, a full contact with function earth (FE) socket of the module not be guaranteed. This may lead to restrictions in the shielding.
- To protect the module from tensile forces that may arise, do not bridge spaces with it.
- Screw the module down only on flat contact surfaces to protect it from warping.
- Ensure that the connectors are not soiled during installation. Dirt and other such substances damage the contacts, allowing corrosion to develop.
- To avoid damaging the module, do not mount it in shear areas of moving devices.
- Arrange for a sufficient potential equalization in your system.
- Use all mounting holes to mount the module to your system so all FE (function earth) connections lie on a ground potential.

Any mounting position is possible.

Note



Ensure a safe mounting position!

In explosion hazardous environments no increased mechanical loads must be present at the installation location. If shocks are possible, a shock protection must be installed between the module and the possible source of the shock.

4.2 Tools and Accessories Required for Mounting

Depending on the mounting type, the following tools are required for installation:

- A screwdriver for M4 fixing screws
- Drilling machine to pre-drill the mounting holes for the module to be mounted to the system and, if applicable, for the imperforated carrier rail.
- M4 thread cutter (bottoming tap or hand tap set)

The WAGO accessories listed below are required for mounting. The associated item numbers can also be found in the 767 Series fieldbus manuals, in the "Accessories" section. Select the manual appropriate to the fieldbus you are using.

- Carrier rail adapter, including fixing screws and perforated or imperforated carrier rails (DIN rail 35 x 7.5 or DIN rail 35 x 15) according to EN 60715, also available from WAGO.

or

- Profile adapter, including fixing screws
- Spacer (optional)

Two M4x12 screws are required for direct mounting of the module. The length of the screw shaft is to be selected according to the mounting type.

Bore measurements

When fastening the 767 Series components without a threaded hole, the clearance hole must not be wider than 4 mm so as to ensure safe contact of the FG (functional ground) connections.

4.3 Direct Mounting on Your System

Mount the module directly on a level surface of your system, without using WAGO accessories. Direct mounting of the module is to be carried out as follows:

1. Disconnect the power supply from those devices on which you wish to mount the module.
2. Mark the drill holes using the hole drilling template printed on the packaging. You can also hold the module in the desired position and mark the drill holes. Ensure that there is sufficient space around the 767 Series components to enable you to connect all cable without problems.

Note



Direct Mounting

We recommend using WAGO spacers for compact direct mounting. If these are used, the resulting additional distance from the second 767 Series component is to be noted. See section “Mounting the Module” > “Mounting the Spacer in the Case of Compact Arrangement”.

3. Fasten the module with two M4x12 screws via the two mounting holes.

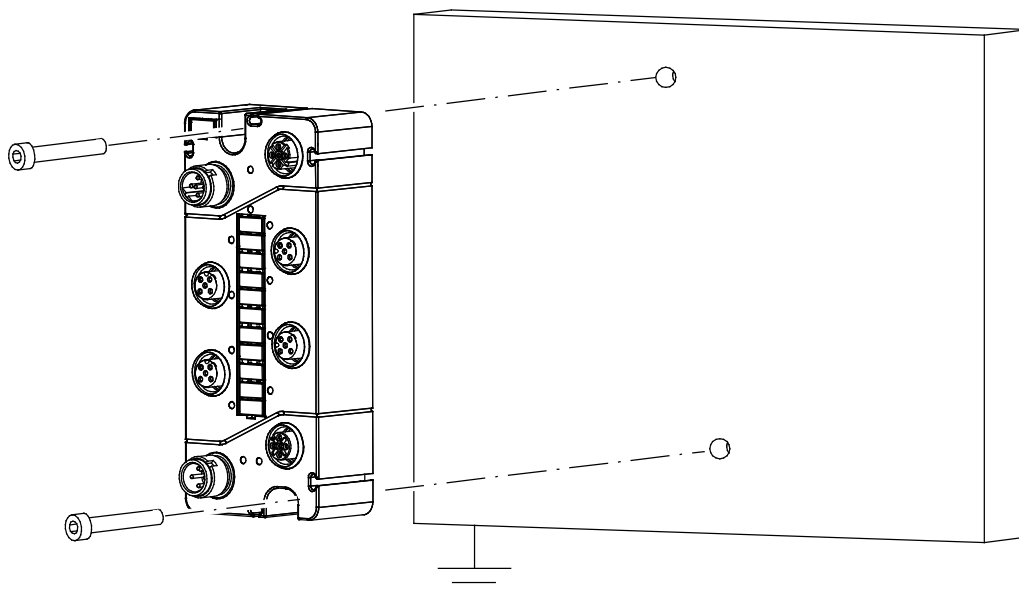

Figure 8: Mounting the module on a grounded frame or to another grounding point

4.4 Mounting on a Carrier Rail (only with WAGO Accessories)

4.4.1 Fastening the Carrier Rail Adapter to the Module

A carrier rail adapter is required to mount the module on carrier rails.

Screw together the module and carrier rail adapter using the M4 threaded screws provided, as shown in the figure below.

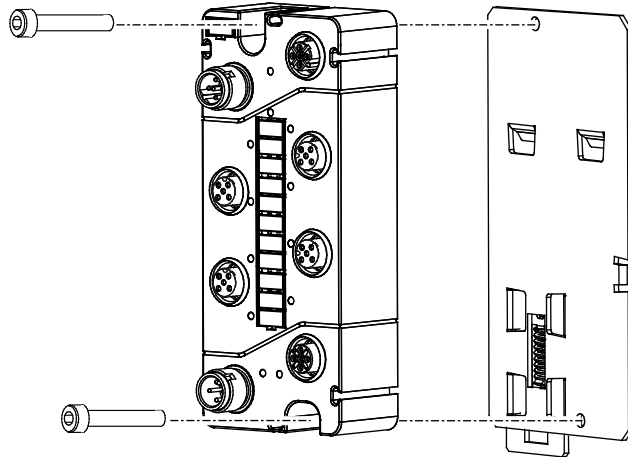

Figure 9: Fastening to the carrier rail adapter

4.4.2 Fastening the Module with Carrier Rail Adapter to a Carrier Rail

In order to provide a clear representation, the carrier rail adapter in the figure below is shown without module.

When mounting the module to a carrier rail (DIN rail 35 x 7.5) using a carrier rail adapter, proceed as follows:

1. Disconnect the power supply from those devices on which you wish to mount the module.
2. Set the module onto the edge of the carrier rail (51) with the two notches (50).
3. Press the undersurface against the lower carrier rail edge until the latch (52) locks in place.

Note



Use end stops

When mounting the rail vertically or if shock or vibration loading should occur, the use of end stops (item no.: 249-116 or 249-117) for stabilization is required.

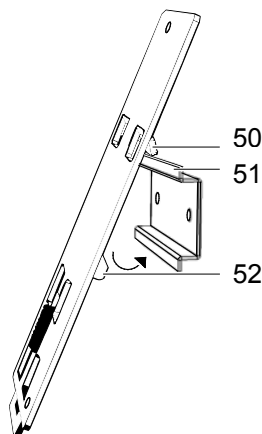

Figure 10: Mounting the carrier rail adapter (exemplary)

4.5 Mounting on a Profile Rail (only with WAGO Accessories)

4.5.1 Fastening the Profile Adapter to the Module

Aside from using carrier rail adapters to fasten the module, you also have the option to fasten it to a profile rail using the profile adapter and nuts, provided that this mounting type is supported by your system. You are to supply the necessary nuts.

Screw together the module and the profile adapter using the M4 threaded screws provided, as shown in the following figure.

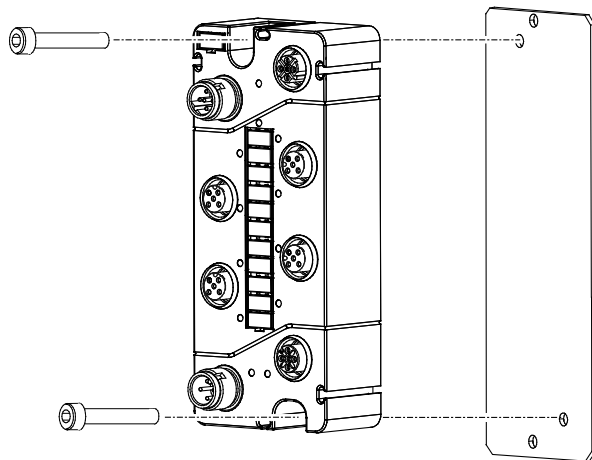

Figure 11: Fastening to the profile adapter

4.5.2 Fastening the Module with Profile Adapter to a Profile Rail

To fasten the module to a profile rail of your system, two nuts are required with one screw each (length of screw threads must be compatible with your system).

1. Disconnect the power supply from those devices on which you wish to mount the module.
2. Insert the two screws into the holes above and beneath the fastened module on the profile adapter.
3. Fasten an appropriate nut on each of these screws.
4. Insert the profile adapter with the attached module into the profile rail of your system. Position it and tighten the screws.

4.6 Marking and Replacing the Marking Spaces

The module marker card (10) and marking strip (12) are attached when delivered. The protective cover is to be removed when labeling the marking strip. To do this, proceed as follows:

1. Press the slot screwdriver (maximum slot width: 3mm) into the small opening under the marking strip cover (12) and lever it up.
2. Remove the marking strip cover.
3. Mark the marking strip with a waterproof pen.
4. Reinsert the marking strip cover and press it firmly in place.

If the module's marker card (10) must be replaced, proceed in accordance with the step sequence described previously. New module marker cards can be obtained through WAGO.

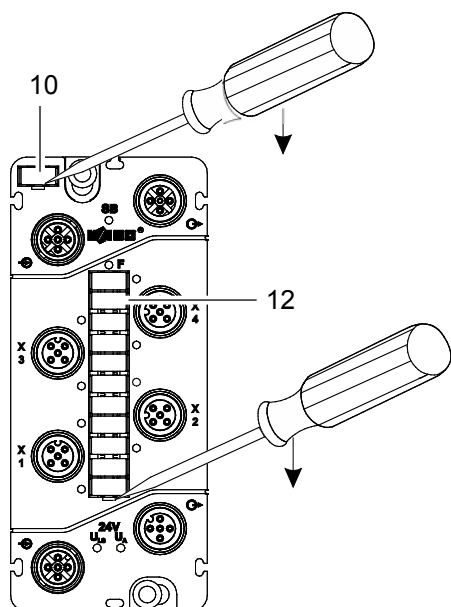

Figure 12: Replacing the marking spaces

4.7 Mounting the Spacer in the Case of Compact Arrangement

By using the spacer, a sufficient mounting distance can be achieved when directly mounting the 767 Series components, and gaps can be eliminated where otherwise dirt and other substances could accumulate. In addition, it is possible to optimize the cable routing. For this purpose, two fastening lugs each are included on the spacer for cable ties.

1. Disconnect the power supply from those devices on which you wish to mount the module.
2. The spacer can only be inserted into the appropriate openings of the module from the bottom. To bind both components, place the module on the spacer or push the spacer from the bottom into the module.
3. Fasten the attached components on a flat surface by fastening the module to the grounded frame of your system or to another grounding point with two M4 screws via the mounting holes.

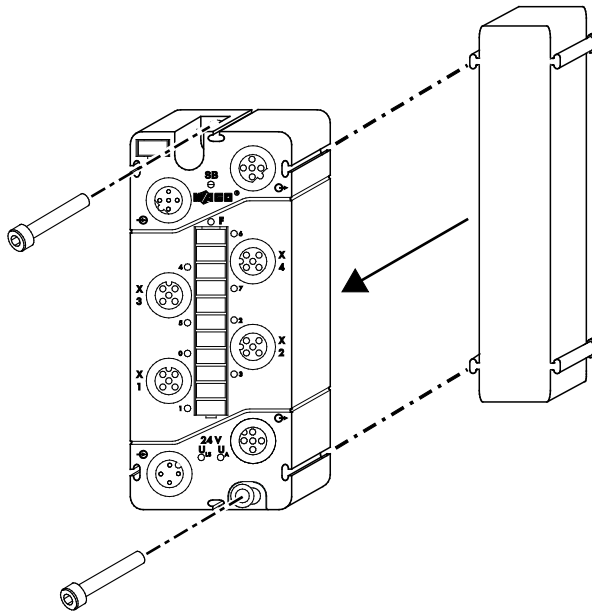

Figure 13: Attaching a spacer to a module

- 4. When attaching 767 Series component, only one 767 component connected with a spacer can be attached and screwed on to the preceding component due to the mounting direction. The last 767 component is fastened without a spacer.

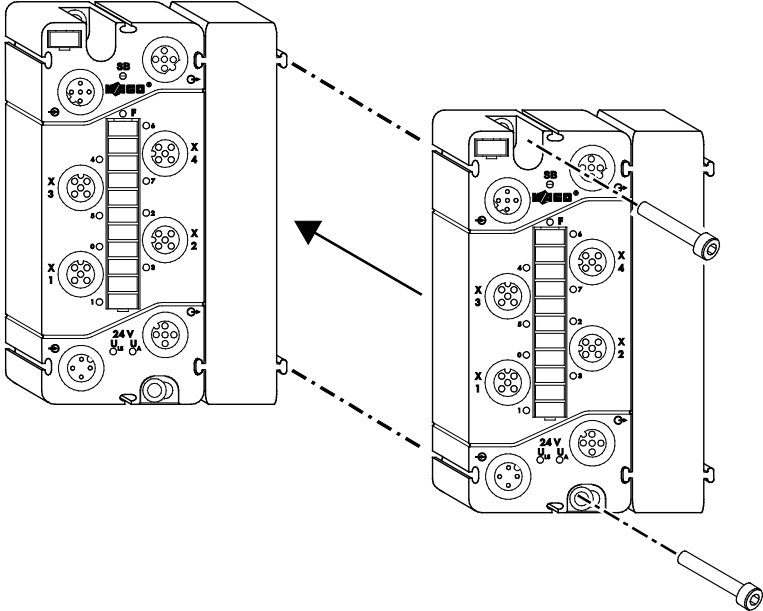

Figure 14: Attaching another module with a spacer

5 Connecting Data and Supply Cables

5.1 Notes



DANGER

Electric voltage!

Operate the 767 Series components exclusively with 24 VDC PELV (Protective Extra Low Voltage) or SELV (Safety Extra Low Voltage) voltage sources. Failure to comply may result in electric shock.

NOTICE

The highest current carrying capacity of the supply contacts is 4 A!

Always observe the maximum current carrying capacity per supply line (U_{LS} , U_A) for each 767 Series component and the overall power consumption for all 767 components. Neither of these values shall exceed 4 A since an increase in current causes the contacts to overheat and damages the 767 Series components. Information regarding the power demand of each 767 Series component can be found in the corresponding data sheet, which is available from www.wago.com.

NOTICE

Exposed connections!

If connections have not been closed with protective caps, liquid or dirt can penetrate the components of the 767 Series module and ruin it. Therefore, close all unnecessary connections with protective caps, which must be ordered separately, in order to maintain the IP67 degree of protection. (See section “Accessories” of the fieldbus coupler/controller manual.)

- The connectors must be disconnected from the power supply when screws are tightened.
- Tighten the connectors by hand. To achieve the required torque (see below) for the connector, use the torque wrench with the order number **206-701**.

Torque for M8 connectors:	0.6 Nm
Torque for M12 connectors:	1.0 Nm

NOTICE

Use torque wrench 206-701!

Only use the specified torque wrench. Using mechanical tools can cause the threads to strip.

In this case, replace the module!

- For both power supply and S-BUS, use only pre-assembled WAGO system cables so the specified characteristics of the technical data can be achieved.

- Do not use drop lines under any circumstances. This can lead to amplified line reflections and signal distortions, which greatly impair the transmission quality.
- Observe the exact positioning (coding) between plug and socket.
- Keep all cables a sufficient distance away from electromagnetic sources of interference in order to maintain a high level of interference resistance of the 767 system against electromagnetic emissions.
- Observe the minimum bending radiuses of the WAGO system cable. For more information, see the technical data at www.wago.com.
- When laying all cable, ensure that you do not lay it in shear areas of moving machine parts.
- Observe the correct layout of the potential equalization.

5.2 Required Accessories

The WAGO accessories listed below are required for connecting the data and supply cable. The associated item numbers can also be found in the fieldbus manuals for 767 Series, in the "Accessories" section. Select the manual appropriate to the 767 Series fieldbus you are using.

- S-BUS M12 terminator, IP 67
- S-BUS and supply cables, pre-assembled on both ends, IP 67
- Torque wrench
- Protective caps

5.3 Connecting the S-BUS Cables

The S-BUS is used for communication between a fieldbus coupler and the connected 767 Series components.

Requirement:



- A WAGO S-BUS cable pre-assembled on both ends is readily available to you. This is necessary for optimal signal transmission.
- The S-BUS terminator is available to you, which is necessary for communication.

The following table outlines the assignment of the S-BUS connections:

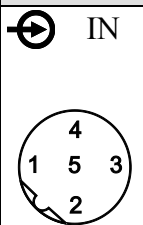
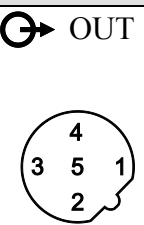
Table 19: S-BUS connection assignment

Connection		Contact	Description	
			IN	OUT
		1	RD +	TD +
		2	RD -	TD -
		3	TD -	RD -
		4	TD +	RD +
		5	GND	
		Connecting thread	Shield	

To connect the S-BUS cables to fieldbus coupler and I/O modules, proceed as follows:

1. Disconnect the power supply from those devices on which you have mounted the module.
2. Connect the S-BUS cable (S1) with the OUT connection  (3) of the fieldbus coupler and the IN connection  (1) of the module. For example, if two I/O modules have been connected to the fieldbus coupler, connect the S-BUS cables (S1, S2) to the associated IN and OUT connections, as shown in the following figure.
3. Tighten the plugs and sockets using the knurled-head screws.
4. Attach the S-BUS terminator (T) to the last I/O module as shown in the figure and tighten it.

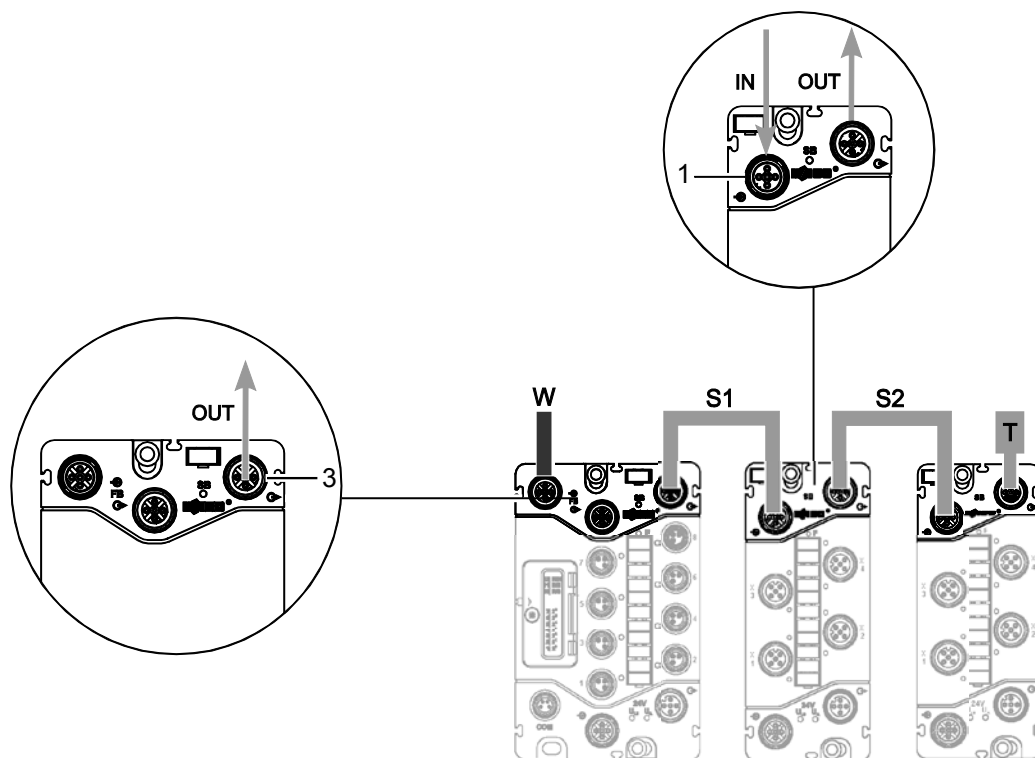

Figure 15: S-BUS connected to a fieldbus coupler and modules

5.4 Connecting the Supply Cable

The supply cable provides power to the module.

Requirement:

The WAGO supply cables K1 and K2, which are pre-assembled on both ends, must be available (see figure on next page).

The following table outlines the assignment of the supply connections:

Table 20: Supply connection assignment

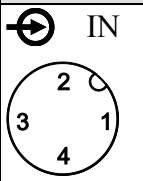
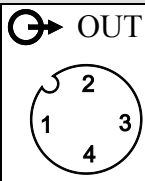

Connection		Contact	Description
		1	24 VDC U_{LS}
		2	24 VDC U_A
		3	0 V U_{LS}
		4	0 V U_A

NOTICE

The highest current carrying capacity of the supply contacts is 4 A!

Always observe the maximum current carrying capacity per supply line (U_{LS} , U_A) for each 767 Series component and the overall power consumption for all 767 components. Neither of these values shall exceed 4 A since an increase in current causes the contacts to overheat and damages the 767 Series components. Information regarding the power demand of each 767 Series component can be found in the corresponding data sheet, which is available from www.wago.com.

To connect the supply cable to the fieldbus coupler and modules, proceed as follows:

1. Disconnect the power supply from those devices on which you have mounted the module.
2. Connect the power supply cable (K1) to the  OUT connection (9) of the fieldbus coupler and the  IN connection (5) of the module.
For example, if two modules have been connected to the fieldbus coupler, connect the power supply transmission cable (K1, K2) with the associated IN and OUT connections, as shown in the following figure.
3. Tighten the plugs and sockets using the knurled-head screws.
4. Screw a protective cap on all unused ports to ensure that IP 67 degree of protection is provided.

Information on connecting the power supply cable (K0) to the "IN" port  (6) of a fieldbus coupler can be found in the appropriate manuals.

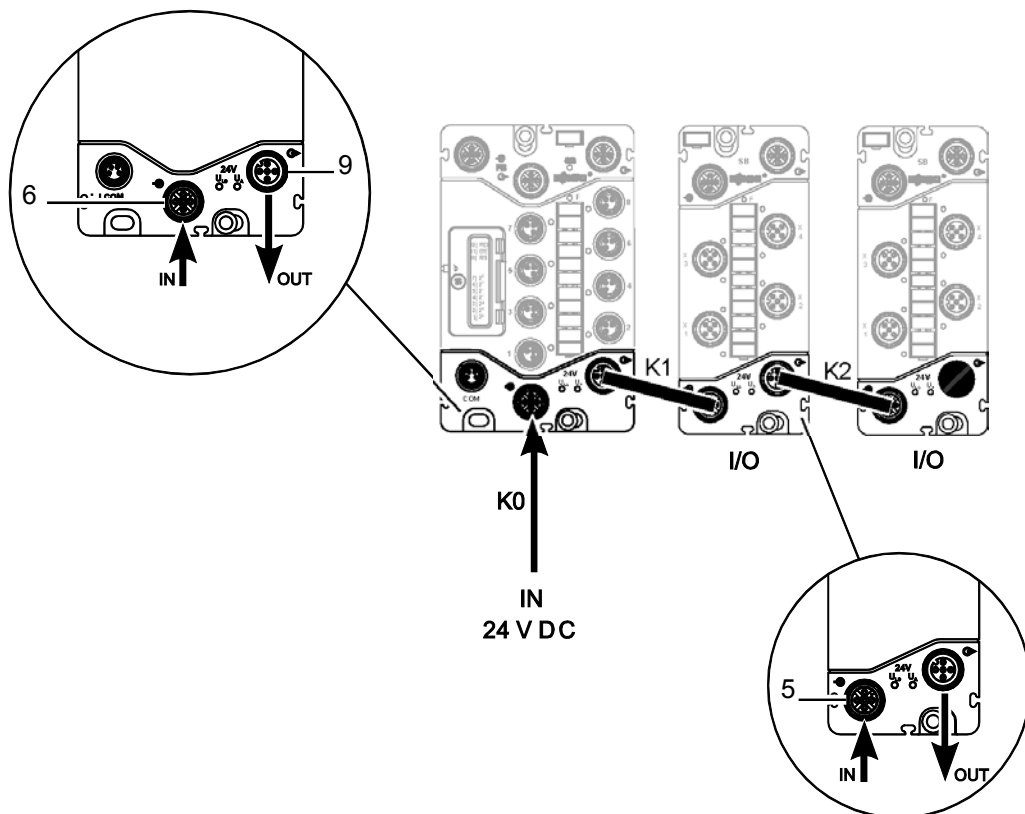

Figure 16: Supply cable connected to a fieldbus coupler and modules

5.5 Connect the Sensor Cable

The sensor cables provide power to the connected sensors and transmit the sensor signals.

When using cables that have not been pre-assembled, make sure that these cables are shielded and equipped with M12 plugs rated to IP67. The following table outlines the assignment of the sensor connections:

Table 21: Connection assignment of analog inputs

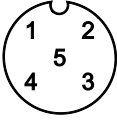
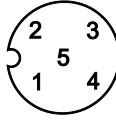
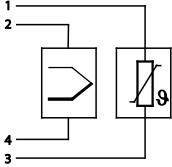
Connection		Connection diagram
IN  X1, X3	IN  X2, X4	<p>1: Compl/Pt1000 2: In+/TC+ 3: GND/Pt1000 4: In-/TC- 5: Shield</p> 

Connecting a Pt1000 for cold junction compensation

You have the option to use a Pt1000 sensor for cold junction compensation in the IP 67 plugs. It should be noted that a Class B Pt1000 sensor or better is used.

Configurable IP67 plugs (756-9207/0050-0000) with suitable integrated Pt1000 sensors are available from WAGO.

Note



Measuring accuracy of the module

The measuring accuracy of the module is directly depending on the accuracy of the cold junction temperature measurement. When using a common junction temperature sensor for multiple channels, ensure that the sensor is not affected by self-heating of the module. This can happen, for example, if behind the module additional modules are connected that need a higher current over the supply lines.

To connect the sensors to the digital inputs, proceed as follows:

1. Disconnect the power supply from those devices on which you have mounted the module.
2. Insert the sensor cable plug into an input socket (3) on the module, and tighten it via knurled-head screw.
3. Screw a protective cap on all unused ports to ensure that IP67 degree of protection is provided.

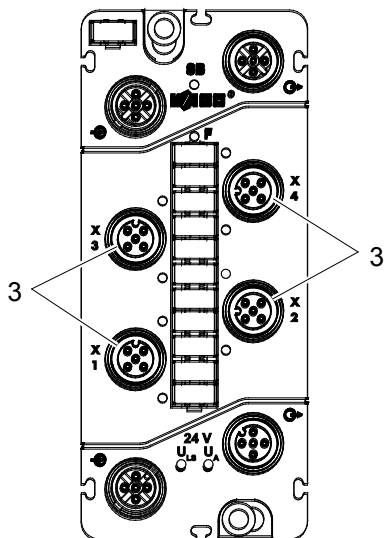

Figure 17: Connectors M12 (exemplary)

6 Commissioning

NOTICE

Exposed connections!

If connections have not been closed with protective caps, liquid or dirt can penetrate the components of the 767 Series module and ruin it. Therefore, close all unnecessary connections with protective caps, which must be ordered separately, in order to maintain the IP67 degree of protection. (See section "Accessories" of the fieldbus coupler/controller manual.)

Before starting up the 767 node, ensure that the following requirements are met:

- Both 767 Series Fieldbus Coupler and Module 767-6403 have been properly mounted (See also fieldbus coupler manuals Series 767).
- The fieldbus, all necessary supply and sensor lines, and the S-BUS bus terminator are all securely fastened onto the appropriate connections (see section "Connecting Data and Supply Cables").
- An appropriate potential equalization is implemented in your system.
- Shielding is carried out properly.

7 Parameterizing

All parameters listed here can be set using WAGOframe (or another FDT/DTM frame application) for the module.

If you use a fieldbus for the parameterization, only certain parameters are configurable, depending on the type of fieldbus.

DANGER

Changing parameters!

When parameters are incorrectly modified via FDT/DTM frame application (e.g., WAGOframe), machine components could be placed in a dangerous state and personnel and machines could be at risk.

Before changing the parameters, ensure that the machine components are in a safe and defined state and switch off the higher-level controller.

Also ensure before start-up that no personnel remain in the danger area of the machine components.

For the parameterization of the module, an appropriate DTM is available. Via this DTM, you can parameterize the module either online or offline. The offline mode enables the parameterization of a module that is not yet present. In the offline mode, first store the parameters in a project and later transfer them to the module.

In the online mode there is a direct link between the display and the connected module. If the module is in the online mode, its name is displayed in **bold** and *italic* font in the network window.

Note



Detailed informations.



Detailed information on handling WAGOframe can be found in the fieldbus coupler manuals.

The following sections provide information on the parameters and their descriptions.

To open the parameterization user interface (DTM) of the module, double-click on the module in the "Network View" of WAGOframe. The parameterization user interface can also be opened by right-clicking on **Offline Parameter** or **Online Parameter** in the context menu.

If several DTMs are open, select one via the corresponding tabs. Depending on the DTM you have selected, different buttons are provided:

Table 22: DTM buttons

Buttons	Description
[Read] (<i>Online mode only</i>)	Reads and displays the parameters found in the module.
[Write] (<i>Online mode only</i>)	Writes the modified values to the module.
[Close] (<i>Online and offline mode</i>)	Closes the parameterization user interface (DTM).
[Apply] (<i>Offline mode only</i>)	Applies the entries in the project. Please note that the project should also be subsequently saved (File > Save).
[Help] (<i>Online and offline mode</i>)	Opens the online help for an entry that has been previously selected in the DTM (e.g., digital inputs, global setting).
	Shows/hides parameter overview.
	Displays the product data sheet. A PDF reader must be installed on your PC.
	Opens the DTM online help.

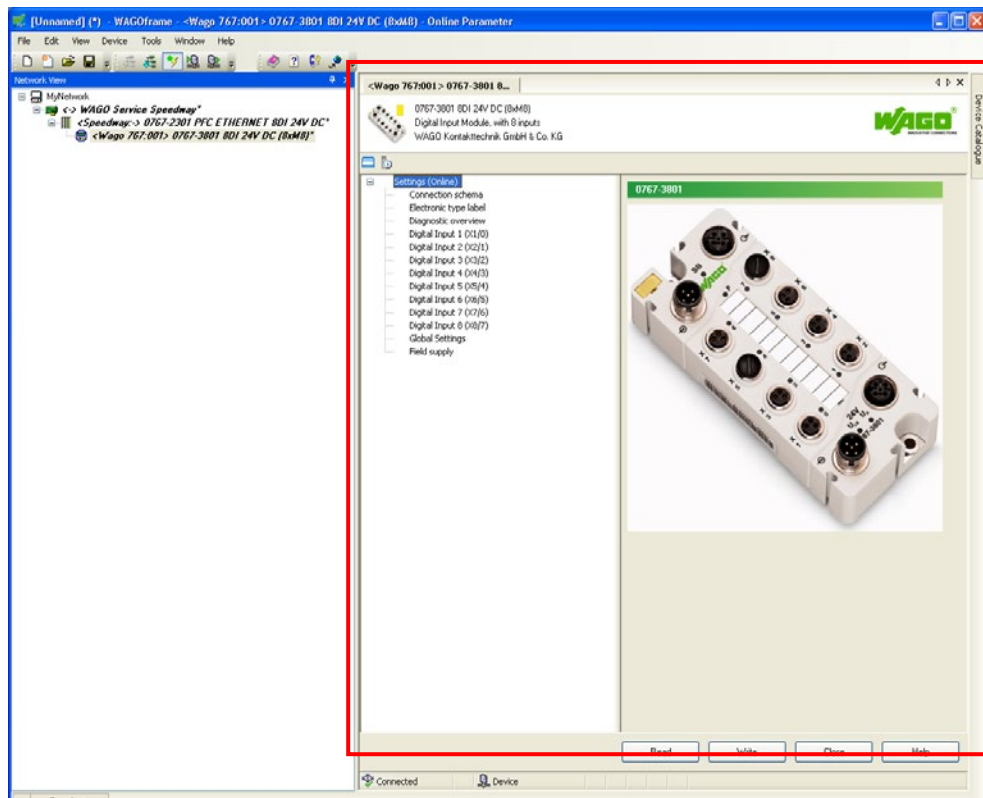

Figure 18: Example of an open DTM, including parameters

7.1 Electronic Type Label

Table 23: Information on the module

Parameter	Description
Vendor	Manufacturer
Release index	FW.HW.FL FW: Actual firmware release index. When updating the firmware, please note that the firmware release index may not be conformed to the printed firmware release index on the side of the fieldbus coupler. HW: Hardware release index FL: Firmware loader release index
Firmware revision	General information on the module
Order number	
Description	
Serial number	
Date of production	
Designation	Electronic marking field

7.2 Diagnostic Overview

The currently pending diagnostics existing on the module are displayed here. In this view of the DTM, you can enable simulation of the diagnostics, as well as disable transmission of the diagnostics. When disabling transmission, make sure that the display behavior of each LED changes that indicates the specific diagnostics (section "Diagnostics" > "LED Signaling"). The diagnostic overview is only available in online mode.

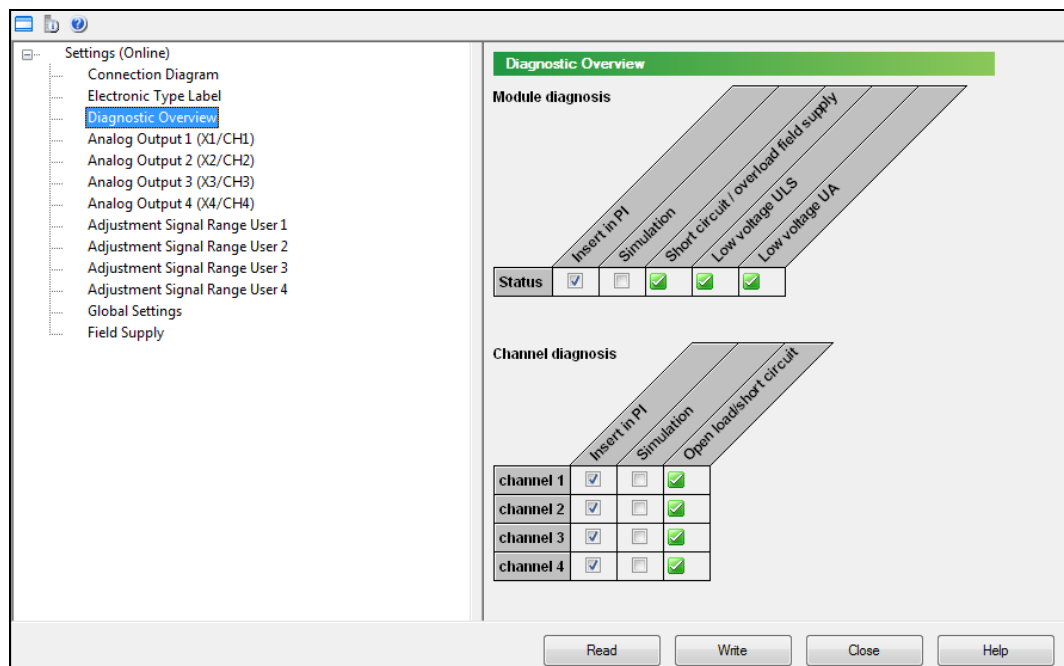

Figure 19: Example of the diagnostic overview of a module (information may differ from the actual module)

Table 24: Diagnostics setup

Parameter	Description
Insert in PI	By unselecting the checkbox, you specifically suppress evaluation and transmission of individual diagnostics. Doing so has no effect on the size of the process image. Even if a diagnostics has occurred, the diagnostic value "0" (no error) is transmitted to the higher-level controller.
Simulation	If you have selected the "Insert in PI" checkbox, the "Simulation" parameter is released. You can select the diagnostics you want to simulate. Click the [Write] button to transfer the simulated values to the module.
Status	Displays whether there is a diagnostics: X mark: There is a diagnostic message. Check mark: There is no diagnostic message.

Table 25: Information about existing module diagnostics

Global Diagnostics	
Diagnostics	Description
Low voltage U_{LS}	If an undervoltage of the logic and sensor supply (U_{LS}) of $< 18\text{ V}$ occurs on the module, a corresponding diagnostic is transmitted to the fieldbus coupler and the F-LED of the module illuminates. The module transmits the substitute value set by DTM as a process value.
Low voltage U_A	If an undervoltage of the actuator supply (U_A) of $< 18\text{ V}$ occurs on the module, a corresponding diagnostic is transmitted to the fieldbus coupler and the F-LED of the module illuminates. The undervoltage of the actuator supply has no functional effect on the module.

Table 26: Information about an existing channel diagnostic

Channel Diagnostics	
Diagnostics	Description
Measuring range underflow	The module has detected an under-run of the measuring range on the respective channel (1 – 4).
Measuring range overflow	The module has detected an overrun of the measuring range on the respective channel (1 – 4).
User limit underflow	The module has detected an under-run of the user range on the respective channel (1 – 4).
User limit overflow	The module has detected an overrun of the user range on the respective channel (1 – 4).
Line break	The module has detected a line break on the respective channel (1 – 4).

7.3 Input Parameters

Table 27: Overview of adjustable parameters for the analogue inputs

Parameter	Description
Designation	Electronic marking field (max. 40 characters)
Display mode process value	Selection of the representation for displaying the process value and limit values: - Decimal - Hexadecimal - Physical
Process image value	An updated measured value for the temperature is displayed here. To keep the temperature in °C, the value should be divided by 10 (see section "Appendix" ... > ... "Measuring Ranges/Process Value Ranges"). If the "Simulation" parameter has been activated, enter the simulation value here.
Measuring Range	Select the measuring range here. You have the following options: Type B Type C Type E Type J Type K* Type N Type R Type S Type T ±36 mV ±72 mV ±145 mV ±290 mV User-defined 1 User-defined 2 User-defined 3 User-defined 4 <div style="text-align: right; border: 1px solid black; padding: 5px; margin: 10px 0;"> <p>Note</p> <p>Measuring ranges The user-defined measuring ranges 1 – 4 can be configured by you. See section "Parameterizing" ... > ... "User-defined Measuring Range 1 – 4".</p> </div> 
Simulation	If this parameter is activated, you can simulate both the process value and the channel-specific diagnostics. Moreover, the input field for the process value is made available so that you can enter the input value that is to be simulated.

Table 27: Overview of adjustable parameters for the analogue inputs

Parameter	Description
Upper limit value (user)	Here you can enter the limit value that is to trigger a diagnostic when exceeded. <i>Default setting: Highest adjustable value</i>
Lower limit value (user)	Here you can set the limit value that is to trigger a diagnostic when under-run. <i>Default setting: Highest adjustable value</i>
Substitute Value	Here you can enter the process value that is transmitted in the case of an error. <i>Default setting: Highest adjustable value</i>
Measuring range underflow	If a limit violation or wire break occurs, the corresponding diagnostic appears. If the "Simulation" parameter is activated, you can simulate the corresponding diagnostic state by selecting this parameter.
Measuring range overflow	
User limit underflow	
User limit overflow	
Line break	
Extended parameters	
Integration Time	Here you can set the integration time of the AD converter. This integration test is ideal for suppressing an interference frequency of 50 Hz or 60 Hz. The following options are available: 2 ms 4 ms 8 ms 16.7ms 20ms 30ms 60 ms* 120ms
Type of cold junction connection	Select the connection type for the cold junction temperature sensor: - Channel switched off - Compensation of fixed value (cold junction temperature) - Compensation sensor of this channel - Compensation sensor of previous channel
Cold junction sensor offset	Enter an offset value for a cold junction temperature error of measurement. <i>Default setting: 0</i>
Cold junction temperature	If you have selected "Compensation of fixed value", enter here a fixed temperature value for the cold junction compensation. Otherwise, only the measured/used cold junction temperature appears here.
Cold junction measuring range underflow	Display of a measuring range under-run for the cold junction temperature measurement.
Cold junction measuring range overflow	Display of a measuring range overrun for the cold junction temperature measurement.

* Default setting

7.4 User-defined Measuring Range 1 – 4

Table 28: Overview of adjustable parameters for the user-defined measuring range

Parameter	Description
Copy Default Setting From	<p>Here you can select the area from which the settings for this measuring range should be acquired. You have the following options:</p> <p>Type B Type C Type E Type J Type K Type N Type R Type S Type T ±36mV ±72mV ±145mV ±290mV User-defined 1 User-defined 2 User-defined 3 User-defined 4</p>
Measuring type	<p>Select the measuring range here. You have the following options:</p> <p>±36 mV ±72 mV ±145 mV ±290 mV</p>
Physical conversion offset	<p>Offset value for calculating the physical value $F(x)$ from the process value (x).</p> <p>$F(x) = (x + \text{conversion offset}) * \text{conversion multiplier}$.</p>
Physical conversion multiplier	<p>Conversion factor (gain) for calculating the physical value $F(x)$ from the process value (x).</p> <p>$F(x) = (x + \text{conversion offset}) * \text{conversion multiplier}$.</p>
Physical unit string	Display of the physical measured value.
Enable user scaling	Here you can activate and deactivate the user scaling ("User Offset" and "User Gain").
User offset	<p>Offset value for scaling the process value. The process value is calculated according to the following formula:</p> <p>$F(x) = (x + \text{user offset}) * \text{user gain}$</p>

Table 28: Overview of adjustable parameters for the user-defined measuring range

Parameter	Description
User gain	<p>Conversion factor (user gain) for scaling the process value. The process value is calculated according to the following formula:</p> $F(x) = (x + \text{user offset}) * \text{user gain}$
Used polynomial	<p>Here you can select the linearization. You have the following options:</p> <ul style="list-style-type: none"> Linear Type B Type C Type E Type J Type K Type N Type R Type S Type T

7.5 Global Settings

Table 29: Overview of parameters for the entire module

Parameter	Description
Simulation diagnostic	If the checkbox is selected, you can simulate a low voltage diagnostic. To generate a low voltage diagnostic, one or both of the two checkboxes "Low voltage U_{LS} " and "Low voltage U_A " must be selected. <i>Default setting: unselected</i>
Low voltage U_{LS}	In the case of an undervoltage of the logic and sensor supply (U_{LS}) or the actuator supply (U_A), the corresponding diagnostic is displayed here.
Low voltage U_A	

7.6 Automatic Storage of System Parameters

Some fieldbus couplers provide the "System Parameter Handling" feature. This serves to identify changes to the configuration of a 767 Series node and to the automatic configuration of the I/O modules. When an I/O module must be replaced due to a defect, you do not need to reconfigure the new I/O module. The stored parameters are automatically transferred to the new I/O module. Detailed information on this procedure can be found in the fieldbus coupler manuals in the "Parameter Setting via FDT/DTM" section.

7.7 Updating the Firmware

When updating the module firmware, the saved module parameters can be overwritten. Therefore, check your existing configuration after updating the firmware.

8 Process Image

The process images for the module listed in the following sections describe the data length on the S-BUS (system bus). The implementation of the S-BUS process images onto the respective fieldbus process images can be found in the fieldbus coupler manuals.

The process image is divided into two areas: an output data area and an input data area. The process image can contain process data with and without diagnostic information, independently of whether the transmission of synchronous diagnostic information has been selected.

Note



Synchronous diagnostic information

Synchronous diagnostic information designates the cyclical transmission of diagnostic information in the process image. This is not selected in the original factory settings for the module.

This is only possible when using a fieldbus coupler that supports the synchronous diagnostic function (e.g. 767-1101 or 767-2301). Detailed information about enabling the transmission of diagnostic information can be found in the manual for the fieldbus coupler being used: see the section about the device description file.

In addition, you can also switch on synchronous diagnostic information in fieldbus couplers that support this function by using an FDT/DTM frame application (e.g. WAGOframe) in the corresponding DTM. For more information, see the Section "Parameterization via FDT/DTM" > "Diagnostics setting" in the fieldbus coupler manuals.

Note



Activate module diagnostics

You can enable or suppress the individual module diagnostics. For more information, see the Section "Diagnostics Overview".

8.1 Input Data

The image for the process data, which are sent from the I/O module to the fieldbus coupler, has a size of 8 bytes. If you configure synchronous diagnostic data for the I/O module, the process image has a size of 11 bytes.

The diagnostic message is structured as follows:

Table 30: Input data in the process image

Byte 0	15 8	Measured value channel 1
8 data bits (signed integer value)		
Byte 1	7 0	Measured value channel 1
8 data bits (signed integer value)		
Byte 2	15 8	Measured value channel 2
8 data bits (signed integer value)		
Byte 3	7 0	Measured value channel 2
8 data bits (signed integer value)		
Byte 4	15 8	Measured value channel 3
8 data bits (signed integer value)		
Byte 5	7 0	Measured value channel 3
8 data bits (signed integer value)		
Byte 6	15 8	Measured value channel 4
8 data bits (signed integer value)		
Byte 7	7 0	Measured value channel 4
8 data bits (signed integer value)		

Byte 8	7								Diagnostic message
								1 _B : Measuring range underflow on channel X1	
								1 _B : Measuring range underflow on channel X2	
								1 _B : Measuring range underflow on channel X3	
								1 _B : Measuring range underflow on channel X4	
								1 _B : Measuring range overflow on channel X1	
								1 _B : Measuring range overflow on channel X2	
								1 _B : Measuring range overflow on channel X3	
								1 _B : Measuring range overflow on channel X4	
Byte 9	7								Diagnostic message
								1 _B : User limit underflow on channel X1	
								1 _B : User limit underflow on channel X2	
								1 _B : User limit underflow on channel X3	
								1 _B : User limit underflow on channel X4	
								1 _B : User limit overflow on channel X1	
								1 _B : User limit overflow on channel X2	
								1 _B : User limit overflow on channel X3	
								1 _B : User limit overflow on channel X4	
Byte 10	7								Diagnostic message, per channel/global
								1 _B : Line break	
								1 _B : Undervoltage U _{LS}	
								1 _B : Undervoltage U _A	

8.2 Output Data

The process image for the output data that is transmitted from the fieldbus coupler to the I/O module has a size of 0 byte. If you configure a synchronous diagnostic confirmation of the I/O module, the process image has a size of 3 bytes.

The diagnostic confirmation is structured as follows:

Table 31: Output data in the process image

Byte 0	7	0	Diagnostic confirmation
			1 _B : Measuring range underflow on channel X1 confirmed 1 _B : Measuring range underflow on channel X2 confirmed 1 _B : Measuring range underflow on channel X3 confirmed 1 _B : Measuring range underflow on channel X4 confirmed 1 _B : Measuring range overflow on channel X1 confirmed 1 _B : Measuring range overflow on channel X2 confirmed 1 _B : Measuring range overflow on channel X3 confirmed 1 _B : Measuring range overflow on channel X4 confirmed
Byte 1	7	0	Diagnostic confirmation
			1 _B : User limit underflow on channel X1 confirmed 1 _B : User limit underflow on channel X2 confirmed 1 _B : User limit underflow on channel X3 confirmed 1 _B : User limit underflow on channel X4 confirmed 1 _B : User limit overflow on channel X1 confirmed 1 _B : User limit overflow on channel X2 confirmed 1 _B : User limit overflow on channel X3 confirmed 1 _B : User limit overflow on channel X4 confirmed
Byte 2	7	0	Diagnostic confirmation, per channel/global
			1 _B : Line break confirmed 1 _B : Undervoltage U_{LS} confirmed 1 _B : Undervoltage U_A confirmed

9 Diagnostics

9.1 LED Signaling

The following table lists the operating messages that are indicated via LEDs. Information regarding remedies of certain causes is also provided.

Note



Disabling specific diagnostics

Use the diagnostic overview (section "Parameterizing" > "Diagnostic Overview") to disable specific diagnostics (see F- and Er-LED). In this case, the corresponding LED is disabled (off).

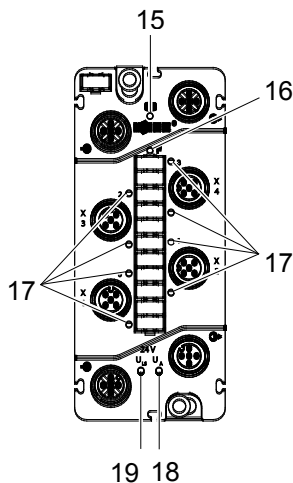

Figure 20: LEDs indicating operational messages (exemplary)

Table 32: Operating messages 1

Pos.	LED	Color/Status	Cause	Remedy/information
15	SB	Off	Low voltage; U_{LS} not available.	Check the power supply.
		Red, flashing, 4 Hz	S-BUS error on module.	Check whether the S-BUS cable is connected. Check the S-BUS cable for damages. Check whether the fieldbus coupler firmware is compatible with the module.
		Red, flashing, 1 or 2 Hz	The module is being restarted via the fieldbus coupler.	If the flashing frequency is 1Hz, please contact WAGO Support.
		Green	Data exchange is in process; process data values are valid. The module is in RUN mode.	-

Table 32: Operating messages 1

Pos.	LED	Color/Status	Cause	Remedy/information
15	SB	Green and orange, flashing, 1 Hz	The set substitute value is applied to the module.	Can be set by the fieldbus coupler if fieldbus is missing. Check the fieldbus connection and the status of the higher-level controller.
		Orange, flashing, 2 Hz	The module has detected the S-BUS.	-
		Orange and green, flashing, 4 Hz	The last module is being detected in the 767 node.	Check the S-BUS terminator and/or the S-BUS cables.
		Orange, flashing, 1 Hz	The fieldbus coupler is addressing the module in the 767 node.	-
		Orange and green, flashing, 2 Hz	The S-BUS parameters are being stored by the fieldbus coupler.	-
		Orange	The firmware is being updated.	All 767 Series components are being updated by the fieldbus coupler within the node.
		Orange, flashing, 4 Hz	The module is attempting to establish communication with the fieldbus coupler.	Check the power supply to upstream 767 Series component and/or check the S-BUS cable for damages.
15	SB	Green, flashing, 1 Hz	The module is in HOLD mode.	Is initiated by the fieldbus coupler. The last input values transferred to the fieldbus coupler are kept in the process image.
		Green, flashing, 2 Hz	The module is in STOP mode.	Is initiated by the fieldbus coupler. The input values are set to 0 in the process image.

Table 33: Operating messages 2

Pos.	LED	Color/status	Cause	Remedy/information
16	F	Red	An undervoltage of < 18 V of the actuator supply and/or logic and sensor supply is present.	Check the power supply of the previous 767 component.
17	Ch1 – Ch4	Yellow	The corresponding inputs are ready for operation.	-
		Off	An undervoltage of < 18 V of the logic and sensor supply is present.	Check the power supply of the previous 767 component.
	Er1 – Er4	Red	Measuring range exceeded or underrun on the corresponding input.	Select the correct measuring area for the input signal.
		Off	An undervoltage of < 18 V of the logic and sensor supply is present.	Check the power supply of the previous 767 component.
18	U _A	Green	Actuator supply U _A is present.	-
		Off	Actuator supply U _A is not present.	Connect the power supply and check the voltage level, if applicable.
19	U _{LS}	Green	Logic supply and sensor supply U _{LS} are present.	-
		Off	Logic supply and sensor supply U _{LS} are not present.	Connect the power supply and check the voltage level, if applicable.

10 Service

This section contains information on maintenance and service.

10.1 Updating the Firmware

The firmware for the module can be updated. This takes place via the USB connection of a fieldbus coupler. Additional information can be found in the fieldbus manuals in section "Updating the Firmware".

10.2 Replacing the Module

To replace a module, e.g., to change variants, proceed as described follow.

10.2.1 Disconnecting the Cables

Before removing the connectors, clean the module to ensure that no dirt or other material comes in contact with the connections. This can lead to damage of the contacts.

To unplug the cables, proceed as follows:

1. Disconnect the power supply from those devices on which you have mounted the module.



CAUTION

Hot connection sockets!

Even when taking into account derating, high surface temperatures on the metallic connection sockets and on the enclosure can arise during operation. If the 767 Series component has been in operation, allow it to cool off before moving it.

2. Unscrew all screw connections and remove the cables.

10.2.2 Removing the Module from Your System

To remove the module from your system's framework, proceed as follows:

1. Disconnect the power supply from those devices on which you have mounted the module.
2. Release the module from your system by unscrewing the M4 screws.

10.2.3 Removing the Module from the Carrier Rail

In order to keep the representation unambiguous, the carrier rail adapter in the following figure (B, C) is shown without module.

If the module is mounted on a carrier rail, proceed with the removal as follows:

1. Disconnect the power supply from those devices on which you have mounted the module.
2. To remove the module, press down the release actuator of the carrier rail adapter using a slot screwdriver (B) and remove it from the carrier rail (C).

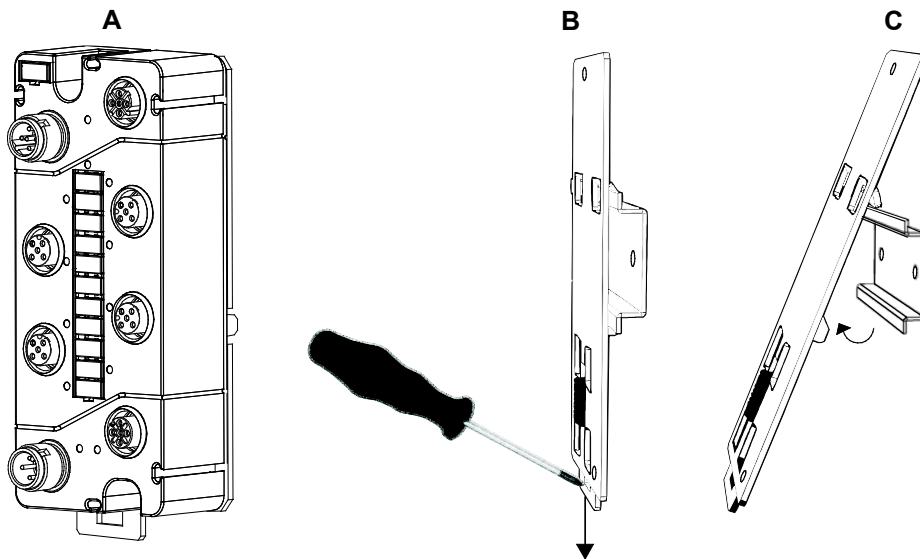

Figure 21: Removing the module (with the carrier rail adapter) from the carrier rail

10.2.4 Removing the Module from the Profile Adapter

If the module is mounted on a profile adapter, proceed with the removal as follows:

1. Disconnect the power supply from that part of the system on which you have mounted the module before attempting to remove it.
2. Unscrew the screws on which the nuts are fastened and remove the module from the profile rail of your system.
3. Unscrew the screws that connect the module with the profile adapter.

10.2.5 Connecting the Module

To connect the module, proceed as described in Sections 4 through 6. If necessary, the parameters of the previous module are transferred to the new module, depending on the type of fieldbus coupler being used. For more information, see section "Parameterizing" > "Automatic Storage of System Parameters".

10.3 Disposal

Do not dispose of the 767 Series components in the household waste; observe the laws which apply to them. You can also contact a certified waste management company.

11 Use in Hazardous Environments

The modular system *WAGO-SPEEDWAY 767* (electrical equipment) is designed for use in *Zone 2* and *22* hazardous areas.

The following sections include both the general identification of components (devices) and the installation regulations to be observed. The individual subsections of the “Installation Regulations” section must be taken into account if the fieldbus coupler and the I/O module of the series *WAGO-SPEEDWAY 767* has the required approval or is subject to the range of application of the ATEX directive.

11.1 Marking Configuration Examples

11.1.1 Marking for Europe According to ATEX and IEC-Ex

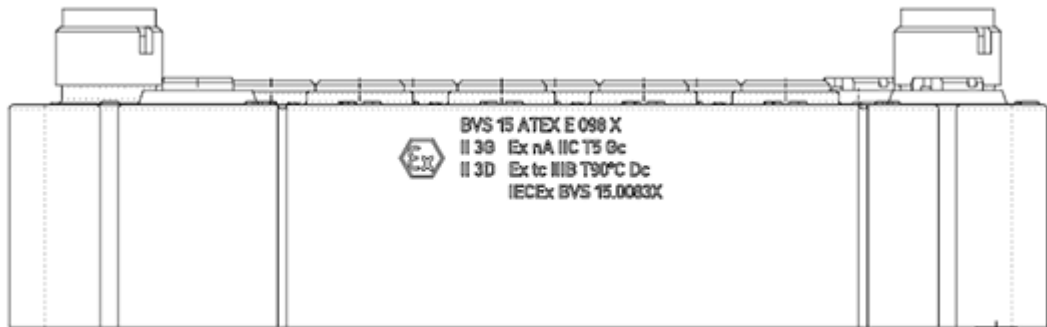

Figure 22: Side Marking Example for approved WAGO SPEEDWAY 767 Series Fieldbus Coupler according to ATEX and IECEx

Table 34: Legend for Figure “Side Marking Example for approved WAGO SPEEDWAY 767 Series Fieldbus Coupler according to ATEX and IECEx”

Printing on Text	Description
BVS 15 ATEX E098X IECEX BVS 15.0083X	Approving authority and certificate numbers
Dust	
II	Equipment group: All except mining
3D	Category 3 (Zone 22)
Ex	Explosion protection mark
Tc Dc	Type of protection and equipment protection level (EPL): protection by enclosure
IIIB	Explosion group of dust
T90°C	Max. surface temperature of the enclosure (without a dust layer)
Gases	
II	Equipment group: All except mining
3G	Category 3 (Zone 2)
Ex	Explosion protection mark
nA Gc	Type of protection and equipment protection level (EPL): Non-sparking equipment
IIC	Explosion group of gas and vapours
T5	Temperature class: Max. surface temperature 100 °C

11.2 Installation Regulations

For the installation and operation of electrical equipment in hazardous areas, the valid national and international rules and regulations which are applicable at the installation location must be carefully followed.

11.2.1 Special Conditions for Safe Use (ATEX Certificate BVS 15 ATEX E098X)

1. The Modular I/O-System has to be protected against UV emitting light.
2. The permitted ambient temperature range is -25°C ... $+50^{\circ}\text{C}$.
3. The Modular I/O-System has to be installed in a way that it is protected against any mechanical and electrostatical hazards. This may be realized by a protection measure according to the documentation mentioned in the Test Report. In this case the earthing of the metal cage has to be established by the end user.
4. The plug shall be in accordance with all applicable clauses of IEC/EN 60079-0 and IEC/EN 60079-15. A minimum degree of protection IP54 according to IEC/EN 60529 shall be ensured. This may be realized by accessories series 756 of WAGO Kontakttechnik GmbH & Co. KG. In this case the torque is 0.6 Nm.

11.2.2 Special Conditions for Safe Use (IEC Ex Certificate IECEx BVS 15.0083X)

1. The Modular I/O-System has to be protected against UV emitting light.
2. The permitted ambient temperature range is -25°C ... $+50^{\circ}\text{C}$.
3. The Modular I/O-System has to be installed in a way that it is protected against any mechanical and electrostatical hazards. This may be realized by a protection measure according to the documentation mentioned in the Test Report. In this case the earthing of the metal cage has to be established by the end user.
4. The plug shall be in accordance with all applicable clauses of IEC/EN 60079-0 and IEC/EN 60079-15. A minimum degree of protection IP54 according to IEC/EN 60529 shall be ensured. This may be realized by accessories series 756 of WAGO Kontakttechnik GmbH & Co. KG. In this case the torque is 0.6 Nm.

12 Appendix

12.1 Measuring Ranges/Process Value Ranges

The following provides an overview of the measuring value ranges and the associated process value ranges. The indicated values apply to user scaling that is not switched on.

The process data is output as signed 16-bit values; the scaling is adjusted to the measuring area:

Thermocouples

- Value range based on type -2500 ... 23200 (-250 °C ... +2.320 °C)
- Resolution 0.1 K

Voltage range ± 36 mV

- Value range -29000 ... -29000 (-36.25 ... +36.25 mV)
- Resolution 1.25 μ V

Voltage range ± 72 mV

- Value range -29000 ... -29000 (-72.5 ... +72.5 mV)
- Resolution 2.5 μ V

Voltage range ± 145 mV

- Value range -29000 ... -29000 (-145 ... +145 mV)
- Resolution 5 μ V

Voltage range ± 290 mV

- Value range -29000 ... -29000 (-290 ... +290 mV)
- Resolution 10 μ V

The following tables provide an overview of possible process values that can be transmitted by the module:

Table 35: Process values for sensor type K

Temperature [°C]	Binary	Hexadecimal	Decimal
<-210	1111100011001100	F7CC	-4200
-210	1111100011001100	F7CC	-4200
-100	1111110100011000	FC18	-2000
0	0000000000000000	0000	0
200	0000011111010000	5.000.000d	2000
400	0000111110100000	0FA0	4000
600	0001011101110000	1770	6000
800	0001111101000000	1F40	8000
1000	0010011100010000	2710	10000
1200	0010111011100000	2EE0	12000
1370	0011010110000100	3584	13700
>1370	0011010110000100	3584	13700

Table 36: Process values for the voltage range 36 mV

Voltage [mV]	Binary	Hexadecimal	Decimal
<-36.25	1000111110111000	8EB8	-29000
-36.25	1000111110111000	8EB8	-29000
-30	1010001101000000	A240	-24000
-24	1011010100000000	B500	-19200
-18	1100100011000000	C7C0	-14400
-12	1101101110000000	DA80	-9600
-6	1110111001000000	ED40	-4800
0	0000000000000000	0000	0
6	0001001011000000	12C0	4800
12	0010010110000000	2580	9600
18	0011100001000000	3840	14400
24	0100101100000000	4B00	19200
30	0101110111000000	5DC0	24000
36.25	0111000101001000	7148	29000
>36.25	0111000101001000	7148	29000

Table 37: Process values for the voltage range 290 mV

Voltage [mV]	Binary	Hexadecimal	Decimal
<-290	0111000101001000	8EB8	29000
-290	0111000101001000	8EB8	29000
-250	1001111101011000	9E58	-25000
-200	1011001011100000	B1E0	-20000
-150	1100011001101000	C568	-15000
-100	1101100111110000	D8F0	-10000
-50	1110110101111000	EC78	-5000
0	0000000000000000	0000	0
50	0001001110001000	1388	5000
100	0010011100010000	2710	10000
150	0011101010011000	3A98	15000
200	0100111000100000	4E20	20000
250	0110000110101000	61A8	25000
290	0111000101001000	7148	29000
>290	0111000101001000	7148	29000

12.2 Diagnostic Information

Some fieldbus couplers display the error code in the form of an attribute path (CIA), through which diagnostics are clearly assigned. Other fieldbus couplers (e.g., PROFINET I/O or PROFIBUS DP) convert the attribute path into the corresponding fieldbus-specific message.

The module can generate the following diagnostic codes:

Table 38: Diagnostics of the module

Diagnostic Message	Attribute Path			Classification
	C	I	A	
Low voltage U_{LS} (sensor supply)	50	1	128	Diagnostic alarm
Low voltage U_A (actuator supply)	50	1	129	Diagnostic alarm

Table 39: Diagnostics of the individual channels of the module

Diagnostic Message	Attribute Path			Classification
	C	I	A	
Measuring range underflow	10	Channel (1, 2, 3 or 4)	128	Diagnostic alarm
Measuring range overflow	10	Channel (1, 2, 3 or 4)	129	Diagnostic alarm
User area underflow	10	Channel (1, 2, 3 or 4)	130	Process alarm
User area overflow	10	Channel (1, 2, 3 or 4)	131	Process alarm
Overcurrent	10	Channel (1, 2, 3 or 4)	133	Diagnostic alarm

Use the "Diagnostic Overview" to disable specific diagnostics.

List of Figures

Figure 1: Connectors	16
Figure 2: Marking possibilities and fastening (exemplary).....	17
Figure 3: Display elements (exemplary)	18
Figure 4: Labeling	19
Figure 5: Label on the module	20
Figure 6: Schematic diagram.....	21
Figure 7: Dimensions of the module in millimeters (exemplary)	22
Figure 8: Mounting the module on a grounded frame or to another grounding point.....	32
Figure 9: Fastening to the carrier rail adapter	33
Figure 10: Mounting the carrier rail adapter (exemplary).....	34
Figure 11: Fastening to the profile adapter	35
Figure 12: Replacing the marking spaces.....	37
Figure 13: Attaching a spacer to a module.....	38
Figure 14: Attaching another module with a spacer.....	39
Figure 15: S-BUS connected to a fieldbus coupler and modules.....	43
Figure 16: Supply cable connected to a fieldbus coupler and modules	45
Figure 17: Connectors M12 (exemplary)	47
Figure 18: Example of an open DTM, including parameters	50
Figure 19: Example of the diagnostic overview of a module (information may differ from the actual module).....	52
Figure 20: LEDs indicating operational messages (exemplary)	64
Figure 21: Removing the module (with the carrier rail adapter) from the carrier rail	68
Figure 22: Side Marking Example for approved WAGO SPEEDWAY 767 Series Fieldbus Coupler according to ATEX and IECEx.....	71

List of Tables

Table 1: Number Notation.....	9
Table 2: Font Conventions	9
Table 3: Legend for figure "Connectors"	16
Table 4: Legend for figure "Marking possibilities and fastening"	17
Table 5: Legend for figure "Display elements"	18
Table 6: Legend for figure "Labeling"	19
Table 7: Description of manufacturing number	20
Table 8: Technical data – General information	23
Table 9: Technical data – Supply	23
Table 10: Technical data – Communication.....	23
Table 11: Technical data – Inputs	24
Table 12: Technical data – Analog value creation	24
Table 13: Technical data – Failures and errors	25
Table 14: Technical data – Configurable functions	25
Table 15: Technical data – Diagnostics	25
Table 16: Technical data – Process image	25
Table 17: Technical data – Display elements.....	26
Table 18: Technical data – Isolation	26
Table 19: S-BUS connection assignment.....	42
Table 20: Supply connection assignment.....	44
Table 21: Connection assignment of analog inputs.....	46
Table 22: DTM buttons	50
Table 23: Information on the module.....	51
Table 24: Diagnostics setup	52
Table 25: Information about existing module diagnostics	53
Table 26: Information about an existing channel diagnostic	53
Table 27: Overview of adjustable parameters for the analogue inputs	54
Table 28: Overview of adjustable parameters for the user-defined measuring range	56
Table 29: Overview of parameters for the entire module	58
Table 30: Input data in the process image.....	61
Table 31: Output data in the process image	63
Table 32: Operating messages 1	64
Table 33: Operating messages 2.....	66
Table 34: Legend for Figure “Side Marking Example for approved WAGO SPEEDWAY 767 Series Fieldbus Coupler according to ATEX and IECEx”	71
Table 35: Process values for sensor type K.....	76
Table 36: Process values for the voltage range 36 mV	76
Table 37: Process values for the voltage range 290 mV	77
Table 38: Diagnostics of the module.....	78
Table 39: Diagnostics of the individual channels of the module	78

WE! INNOVATE!

WAGO Kontakttechnik GmbH & Co. KG
Postfach 2880 • D-32385 Minden
Hansastraße 27 • D-32423 Minden
Phone: 05 71/8 87 – 0
Fax: 05 71/8 87 – 1 69
E-Mail: info@wago.com
Internet: <http://www.wago.com>

