



WAGO *SPEEDWAY* 767

CANopen, 8 DI, 24 V DC

767-1501

Fieldbus Coupler

Version 2.0.0

Introduction

Every conceivable measure has been taken to ensure the accuracy and completeness of this documentation. However, as errors can never be fully excluded, we always appreciate any information or suggestions for improving the documentation. E-mail: documentation@wago.com

Service and Technical Support

Additional information regarding this and other products (e.g., data sheets) is available on our website www.wago.com.

If you can not eliminate errors or faults using the measures described in this manual we will be glad to assist you further. Contact us at:

AUTOMATION Support
Phone: +49 571 887 555
Fax: +49 571 887 8555
E-mail: support@wago.com

Additional Support

The Seminar and Training department offers useful seminars to support you in the use of WAGO products. For more information, visit our website or call +49 571 887-327, or send an e-mail to training@wago.com.

Trademarks

We wish to point out that the software and hardware terms as well as the trademarks of companies used and/or mentioned in the present manual are generally protected by trademark or patent.

Copyright © 2010 by WAGO Kontakttechnik GmbH & Co. KG. All rights reserved.

Table of Contents

Introduction	2
1 Safety	4
1.1 Notes on This Quick-Start Guide	4
1.2 Explanation of Symbols	5
1.3 Validity of This Quick-Start Guide	7
1.4 Use in Compliance with Underlying Provisions	7
1.5 Personnel Qualification	7
1.6 Basic Safety Information	8
1.7 Safety Equipment	9
1.8 Technical Condition of the 767 Components	10
1.9 Notes on Operation	10
2 Description	11
2.1 Accessories	11
3 Connection	13
3.1 Setting the CANopen Station Address	17
3.2 Setting the Baud Rate	19
4 PLC Configuration in CoDeSys	20
4.1 Configuring the Fieldbus Node	20
5 PLC Program	23
6 WAGOframe	24
6.1 Installation	25
6.2 Starting Up the Fieldbus Coupler	30
6.3 Operation	31
7 System Update	36
7.1 Adding the DTM System Update	37
7.2 Go online to 767 Nodes using Update DTM	38
7.3 Updating the 767 Components	39

1 Safety

1.1 Notes on This Quick-Start Guide

The fieldbus coupler shall only be installed and operated in conjunction with these quick-start instructions and the system description. Detailed information on the coupler is provided in the 767-1501 manual.

WARNING

Observe release notes!

Please note that, within the SPEEDWAY system, a function is provided **without restriction** only if all system's components have the same system-wide firmware release. Therefore, always observe the appropriate release notes on products used.

NOTICE

Supply layout!

In addition to these operating instructions, you will need the "WAGO SPEEDWAY 767, System Description and Information" manual, which can be downloaded at www.wago.com. There you will find information regarding supply layout, etc.

1.2 Explanation of Symbols

 **DANGER****Warning of physical injury**

Indicates a direct hazard with a high level of risk which leads to death or serious physical injury if not avoided.

 **DANGER****Warning of physical injury from electric current**

Indicates a direct hazard with a high level of risk which leads to death or serious physical injury if not avoided.

 **WARNING****Warning of physical injury**

Indicates a possible hazard with a moderate level of risk, which may lead to death or (serious) physical injury if not avoided.

 **CAUTION****Warning of physical injury**

Indicates possible hazards with a low level of risk, which could lead to minor or moderate physical injuries if not avoided.

NOTICE**Warning of damage to equipment**

Indicates a possible hazard that could lead to equipment damage if not avoided.

NOTICE**Warning of damage to equipment from electrostatic discharge**

Indicates a possible hazard that could lead to equipment damage if not avoided.

Note



Please note

Indicates possible malfunction, which does not lead to equipment damage if it is not avoided.

Information



Reference to additional information

Indicates other sources of information which are not an integral part of this documentation, such as the Internet.

1.3 Validity of This Quick-Start Guide

These operating instructions are only applicable to the positive-switching WAGO SPEEDWAY 767 Series fieldbus coupler, item number 767-1501.

1.4 Use in Compliance with Underlying Provisions

The CANopen fieldbus coupler provides digital process data from digital and analog I/O modules. The data is gathered by the fieldbus coupler and made available to a higher-level controller for further processing.

The fieldbus coupler shall not be used to control safety-related functions; i.e., emergency-off devices shall not be operated with this fieldbus coupler.

The fieldbus coupler shall only be used as a unit or in combination with I/O modules from the WAGO SPEEDWAY 767 Series.

The fieldbus coupler was developed for applications requiring IP 67 (NEMA type 6, 6P) protection.

The fieldbus coupler is expandable by a maximum of 64 I/O modules from the WAGO SPEEDWAY 767 Series.

Applications other than those described in this manual are not permitted.

1.5 Personnel Qualification

All sequences implemented on the fieldbus coupler may only be carried out by electrical specialists with sufficient knowledge in automation. The specialists must be familiar with the current standards and guidelines for the fieldbus coupler and automation environment.

1.6 Basic Safety Information

This section contains a summary of the most important warnings, which are also repeated in the individual sections. They serve as a protection to your health and a protection from equipment damage on the 767 Series components (fieldbus coupler and the I/O modules connected to it). Read and adhere to the following safety precautions before using the fieldbus coupler.



DANGER

Electric voltage!

Operate the 767 Series components exclusively with 24VDC PELV (Protective Extra Low Voltage) or SELV (Safety Extra Low Voltage) voltage sources. Failure to comply may result in electric shock.

CAUTION

Hot connection sockets!

Even when taking into account derating, high surface temperatures on the metallic connection sockets and on the enclosure can arise during operation. If the 767 Series component has been in operation, allow it to cool off before moving it.

NOTICE

The highest current carrying capacity of the supply contacts is 4A!

Always observe the maximum current carrying capacity per supply line (U_{LS} , U_A) for each 767 Series component and the overall power consumption for all 767 Series component. Neither of these values shall exceed 4A since an increase in current causes the contacts to overheat and damages the 767 Series components. Information regarding the power demand of each 767 Series component can be found in the corresponding data sheet, which is available from www.wago.com.

NOTICE

Exposed connections!

If connections have not been closed with protective covers, liquid or dirt can penetrate the fieldbus coupler and ruin it. Close all unneeded connections with protective caps to ensure that IP 67 degree of protection is provided.

- Disconnect the power supply from the system on which you wish to mount the 767 Series component.
- Always keep the cover cap of the DIP switch closed.
- Observe the appropriate accident prevention regulations for your system during assembly, startup, maintenance and repairs.
- The operating instructions of the 767 Series components and the system description must be readily available at the workplace.

- Observe the exact positioning (coding) between plug and socket.
- The 767 Series component shall not come in contact with substances having seeping and insulating properties. Otherwise, additional measures shall be taken for the devices, such as installation of an enclosure that is resistant to the above-mentioned substance properties.
- Electronic components fulfilling the ESD requirements according to the IEC 61000-6-2 are integrated in the 767 Series component. Since, under unfavorable circumstances, higher voltages may also occur due to electrical charge in the field, discharge must be ensured before performing work on the 767 system.
- Observe the correct layout of the potential equalization.
- Keep all cables a sufficient distance away from electromagnetic sources of interference in order to maintain a high level of interference resistance of the 767 system against electromagnetic emissions. Use only shielded cables at the necessary locations, and always observe the appropriate standards for EMC-suitable installations.
- For the power supply and for the S-BUS, use only pre-assembled WAGO system cables, so the specified characteristics of the technical data can be achieved.
- Replace defective or damaged 767 Series component (e.g., deformed connections), else function disruptions can occur in the respective fieldbus stations or nodes.
- When laying any cables, make sure that you do not lay them within the shear range of movable machine parts.
- For each activity, observe the corresponding personnel qualification in Section 1.5.
- Observe the marking on the front and rear side of the 767 Series component.

1.7 Safety Equipment

All 767 Series products are designed according to the IP 67 safety class. This consists of, among other things, complete touch protection of electric voltages and currents – even when wet.

1.8 Technical Condition of the 767 Components

If any change is made to the 767 Series components or software and firmware without the written approval of WAGO Kontakttechnik GmbH & Co. KG, all liability claims are nullified.

1.9 Notes on Operation

When integrating the 767 Series components in your machine or system, all the currently applicable norms, regulations and guidelines shall be observed during all activities. The emergency stop equipment shall remain effective in all operating modes of the system and machine.

For protection from electromagnetic interferences

- Connect your system to protective earth (PE), and
- Ensure that the cable routing and the installation of the fieldbus cable, S-BUS cable, supply cable, and sensor cable are correct.

The following elements for 24V supply shall be present:

- Outer lightning protection on buildings
- Inner lightning protection of supply lines and signal lines
- Safe electrical separation of low voltage 24VDC through PELV (Protective Extra Low Voltage) or SELV (Safety Extra Low Voltage) voltage sources

2 Description

This quick-start guide describes the process of starting up the 767-1501 Fieldbus Coupler on a 758-870/000-012 Industrial PC.

I/O modules are connected to the fieldbus coupler via the S-BUS (system bus). Start-up is completed in two steps. In the first step, the network is configured using the PLC configuration inside CoDeSys 2.3. In the second step, a minimal PLC program is created with CoDeSys 2.3 that outputs the status of the first digital input on 767-1501 to the first digital output on 767-4801.

2.1 Accessories

This manual was created using the following software and hardware:

Name	Description	Item no./Version
WAGOframe CD-ROM Ver. 3.0.0	FDT/DTM frame application	759-370 Ver. 1.0.8
WAGO USB driver	USB driver for 767 Series	759-922 Ver. 1.3.2
WAGO service interface DTM	DTM for communication	759-371 Ver. 2.1.0
WAGO DTM for fieldbus coupler and I/O modules	Device DTM for 767 series (programmable) fieldbus coupler and I/O modules	759-361 Ver. 2.1.0
System update DTM	DTM for firmware update	759-362 Ver. 1.0.0
USB communication cable (WAGOframe)	M8 plug, straight	756-4101/0042-0030

12 Description

Name	Description	Item no./Version
CANopen cable (A coded), fitted on one end	M12 right-angle socket, 2m	756-1501/0060-0020
CANopen terminator (A coded)	M12 terminating plug, straight	756-9209/0060-0000
S-BUS cable (B coded), fitted on both ends	M12 socket, right angle, M12 plug, right angle, 0.2m	756-1306/0060-0002
S-BUS terminating plug (B coded)	M12 plug, straight	756-9409/0060-0000
Power supply cable (A coded), Fitted on both ends	M12 socket, right angle, M12 plug, right angle, 0.2m	756-3106/0040-0002
Fieldbus coupler for CANopen	FC, 8DI, 24 V DC (8xM8)	767-1501
Digital output module	8 DO, 24 V DC 0,5 A (8 x M8)	767-4801
Industrial PC with CANopen master	PLC	758-870/000-112
CoDeSys	Programing software	759-333

When placing an order, also take into account an additional power supply cable between the power supply unit and the fieldbus coupler, in addition to the number of I/O modules needed.

3 Connection

NOTICE

Exposed connections!

If connections have not been closed with protective covers, liquid or dirt can penetrate the fieldbus coupler and ruin it. Close all unneeded connections with protective caps to ensure that IP 67 degree of protection is provided.

Then tighten the connector by hand when power is switched off. Using mechanical means to tighten it may strip the threads. In such a case, the fieldbus coupler is to be replaced.

Tightening torques for the connectors: 0.6 Nm

Wire the 767 components as shown in the following figure:

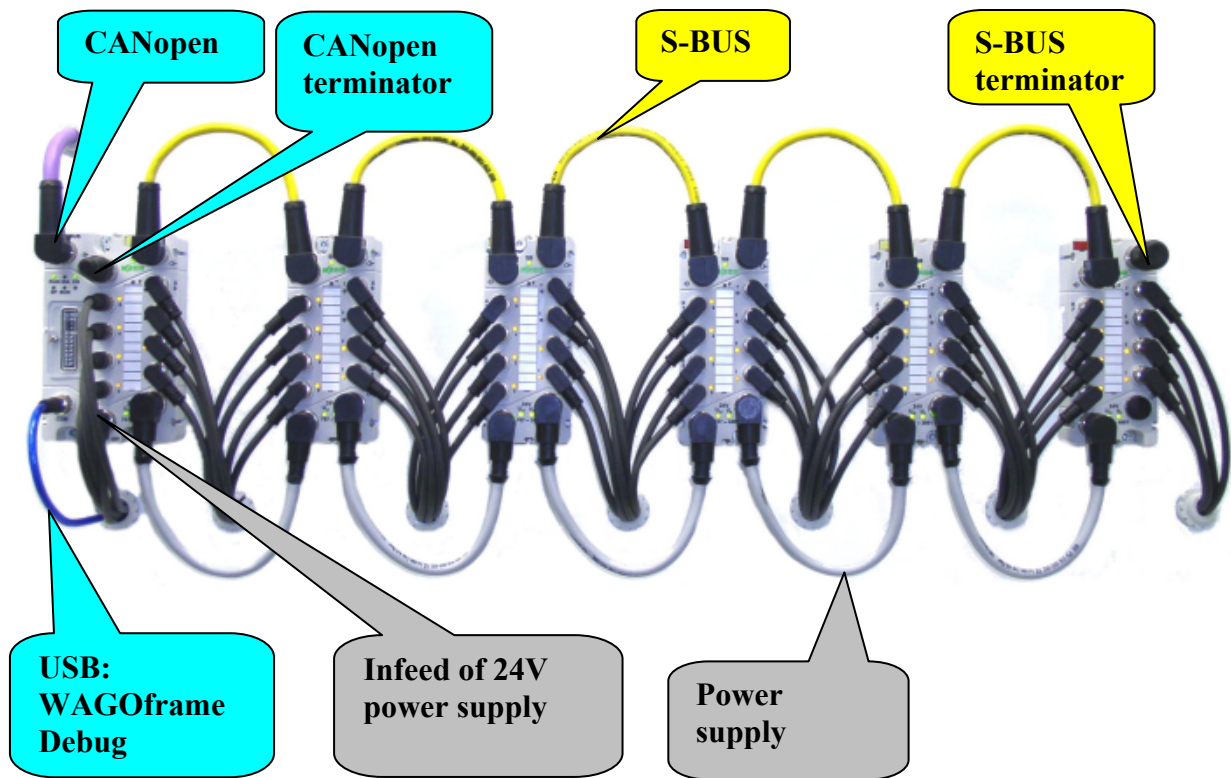

Supply voltage (M12 connectors, A coded, 4 poles):

Power supply feed-in for logic circuits and outputs is provided via separate contacts.

Connection		Contact	Description
		1	24VDC U_{LS}
		2	24VDC U_A
		3	0V U_{LS}
		4	0V U_A

CANopen:

You need a CANopen cable with an A coded M12 socket to connect to the CANopen.

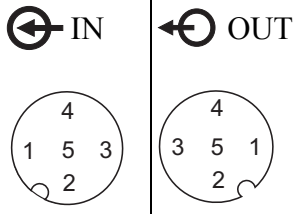
Connection	Contact	Description
	1	CAN_SHILD
	2	CAN_V+
	3	CAN_GND
	4	CAN_H
	5	CAN_L

S-BUS:

The system bus is used for internal communication between the fieldbus coupler and the 767 Series I/O modules connected to it.

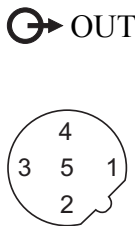
Connection	Contact	Description
	1	TD +
	2	TD -
	3	RD -
	4	RD +
	5	0VDC
	Connecting thread	Shielded

Service port (USB):

The fieldbus coupler provides the following service at the service port:

- I/O-Service
The function "I/O-Service" is used by the FDT/DTM frame application "WAGOframe" to assign parameters to and configure the fieldbus coupler.

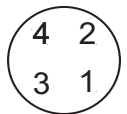
Connection	Contact	Description
	1	+ 5V
	2	- Data
	3	+ Data
	4	0VDC
	Connecting thread	Shielded

The USB Speedway device driver is part of the installation programs of the "WAGOframe" application. For more information, see Chapter Fehler!

Verweisquelle konnte nicht gefunden werden..

Digital inputs:

The sensor cables provide power to the connected sensors and transfer the sensor signals. The table below outlines the connection assignments for the sensor connections:

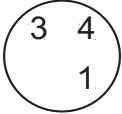
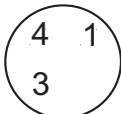
Connection		Contact	Description
IN	IN	1	24VDC (supplied from U_{LS})
		3	0VDC
X1, X3, X5, X7	X2, X4, X6, X8	4	Input

NOTICE**The highest current carrying capacity of the supply contacts is 4A!**

Ensure that the sensors from the U_{LS} supply line are supplied with power. The sensor's power consumption is to be taken into consideration when determining the present power demand for the U_{LS} supply line.

NOTICE**The total maximum power consumption of the sensors must not exceed 400mA (50mA/channel).**

Please note that the combined power consumption of all connected sensors is not to exceed 400mA. The distribution of power among the existing connections is depending on the individual power requirements of the sensors.

3.1 Setting the CANopen Station Address

To integrate the fieldbus coupler in the CAN network, the fieldbus coupler must be assigned an station address that is unique across the network using DIP switches. The address can be any number between 1 and 127. Use switches 1 – 7 to set the address.

Switch	1	2	3	4	5	6	7	8	9	10	11	12
Binary value/ Functions	2 ⁰ (1)	2 ¹ (2)	2 ² (4)	2 ³ (8)	2 ⁴ (16)	2 ⁵ (32)	2 ⁶ (64)	Baud	Baud	-	Boot/ execute	Reset
Switch setting	Off	Off	Off	Off	Off	Off	Off	Off	Off	Off	Off	Off

Requirement:

The fieldbus coupler shall not be connected to the power supply.

To set the station address via the DIP switches, proceed as follows:

1. Open the cover by unscrewing the M3 screw with a screwdriver.
2. Set the CANopen station address by switching the switches 1 – 7 on ("On") or off ("Off") accordingly. With the seven available switches, you can set addresses from 1 – 127. Address 0 is reserved.
3. Close the cover and screw it securely in place to maintain degree of protection IP 67.

Note



The CANopen station address is only active when the fieldbus coupler is connected to the power supply.

In the following example, switches 3, 5 and 6 are switched on. Thus, the CANopen station address of the fieldbus coupler in this example is 52 ($2^2 + 2^4 + 2^5 = 4 + 16 + 32 = 52$).

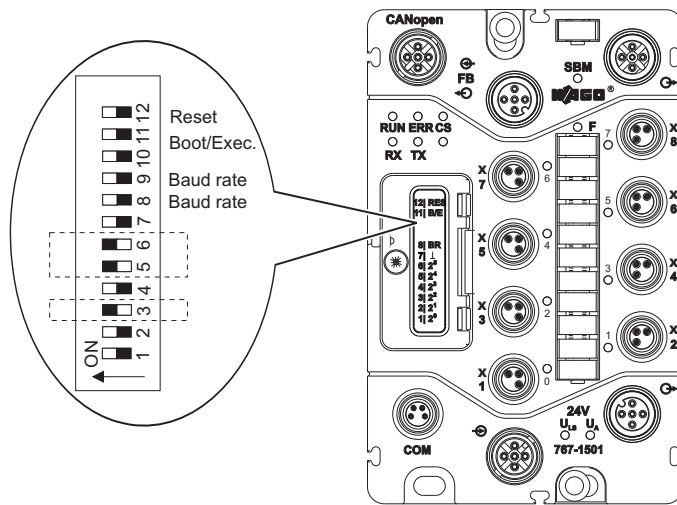

DIP switch set for station address 52

During operation, the device address can be set via the CANopen object or via WAGOframe (see operating instructions for 767-1501). Restart the fieldbus coupler to activate the new station address.

3.2 Setting the Baud Rate

The fieldbus coupler's baud rate can be set via switches 8 and 9. You have the choice between 125kbit/s, 500kbit/s and 1Mbit/s, or you may choose automatic baud rate detection. The assignment of the switch position to the baud rate is shown in the table below.

Switch	Switch setting			
	8	Off	On	Off
9	Off	Off	On	On
Baud rate	125 Kbit/s	500 Kbit/s	1 Mbit/s	Automatic baud rate detection

Note



The baud rate is only active when the fieldbus coupler is connected to the power supply.

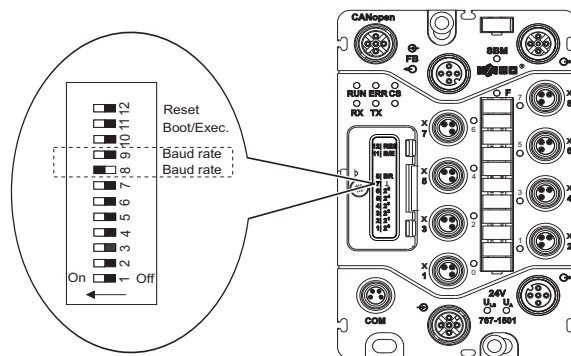

DIP switches set for a 500kbit/s baud rated

4 PLC Configuration in CoDeSys

4.1 Configuring the Fieldbus Node

After opening the PLC configuration, insert the CAN master. To show the CAN module selection in the configuration, it is important that "Support for DSP301 V4.01 and DSP306" is selected in the CAN parameters of the master:

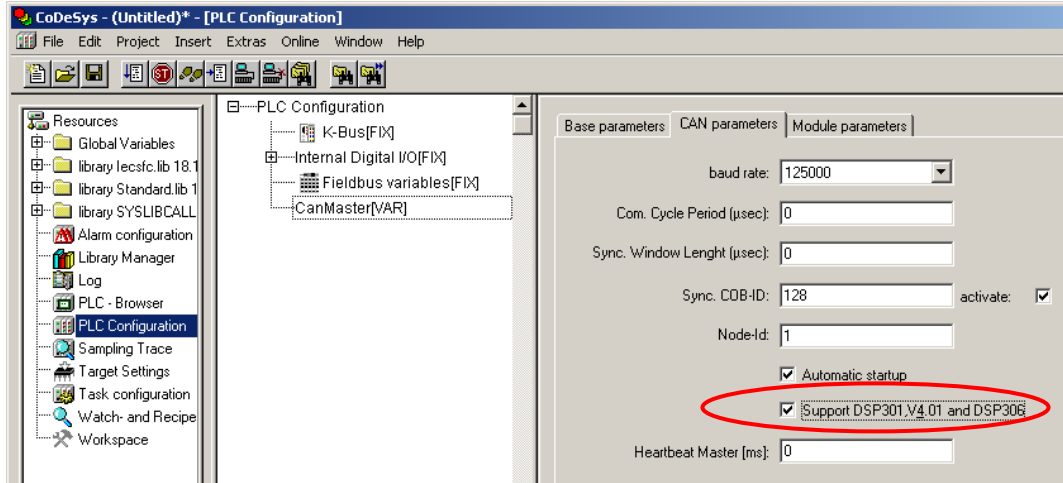

1. Right-click on "CanMaster" and select "Append Subelement" from the context menu. Select "WAGO 767-1501."

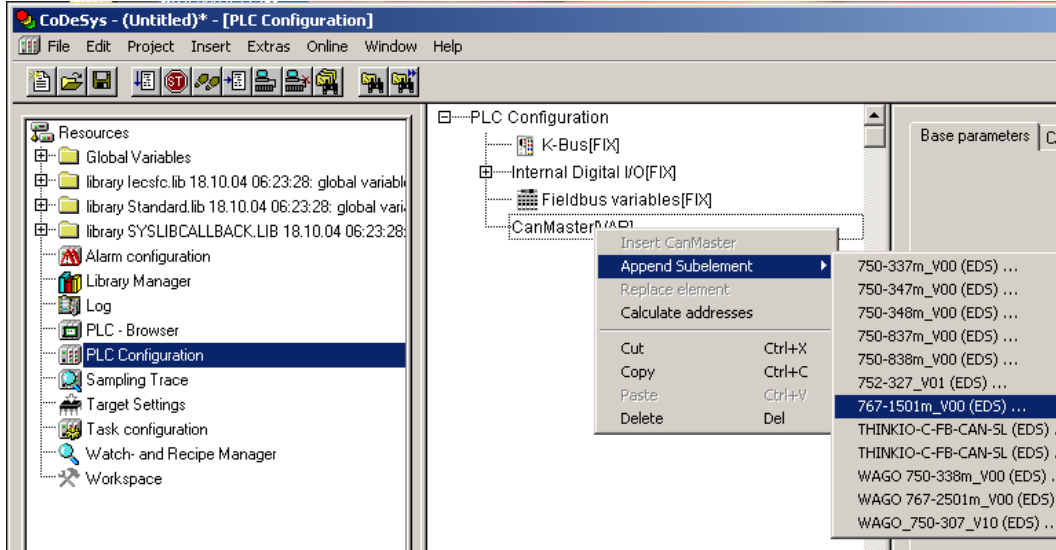

- "Node ID," "Device Type" and "Node Guarding" must be configured in the "CAN Parameter" dialog box.

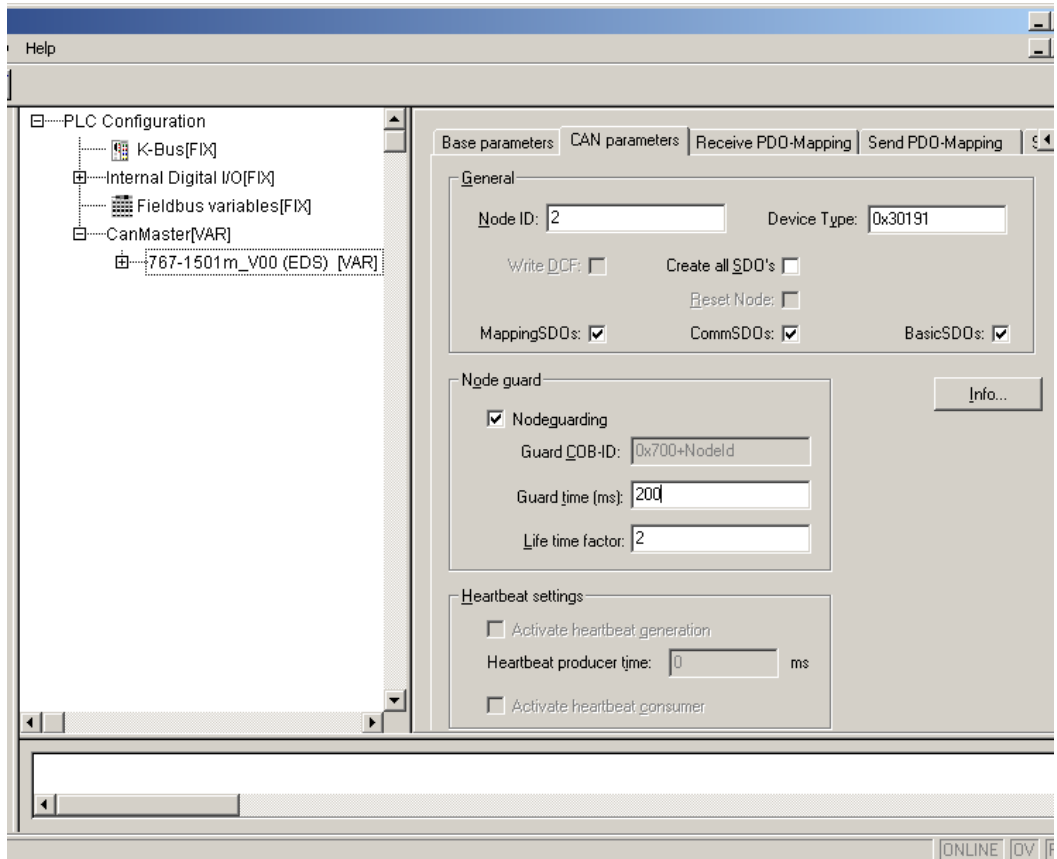

- In the "CAN Module Selection" dialog box, select the I/O modules that correspond to the hardware being used.

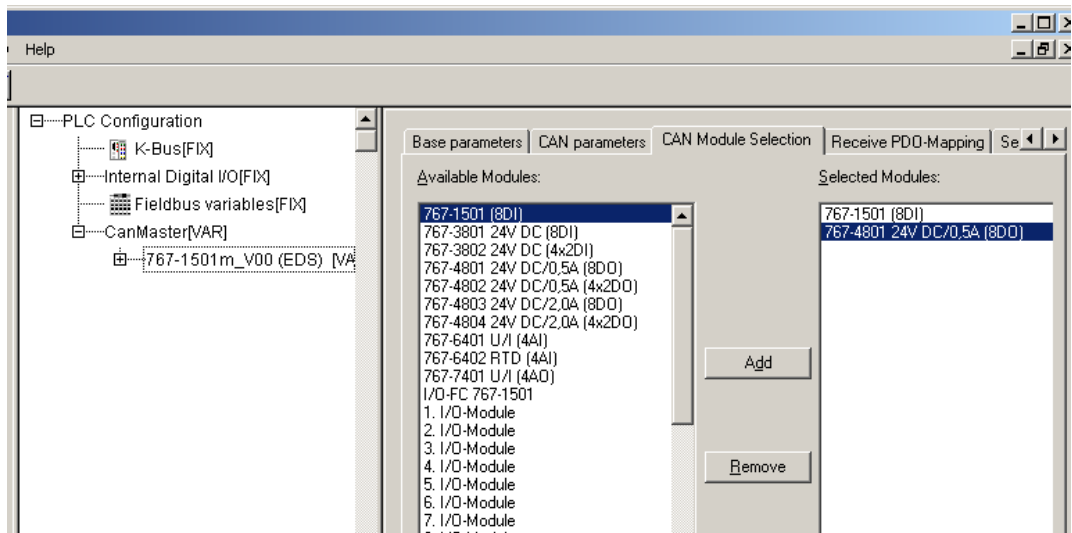

4. You can now assign the symbolic names for the input and output data in the configuration tree. These names can then be used throughout the project to access the inputs and outputs.

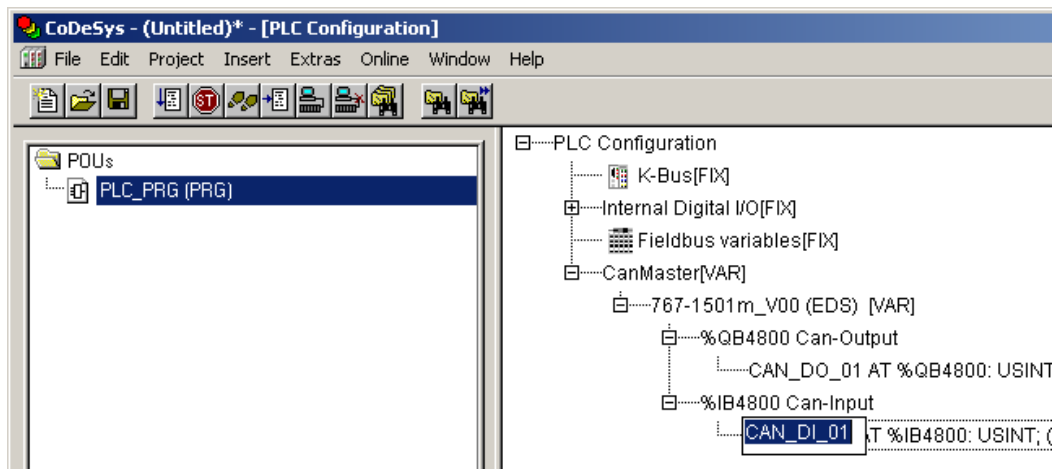

5 PLC Program

The following test program shows easy access to the process data of the connected slave. The status of the first digital input of 767-1501 will be scanned, and its negated value will be assigned to the first output of the 767-4801.

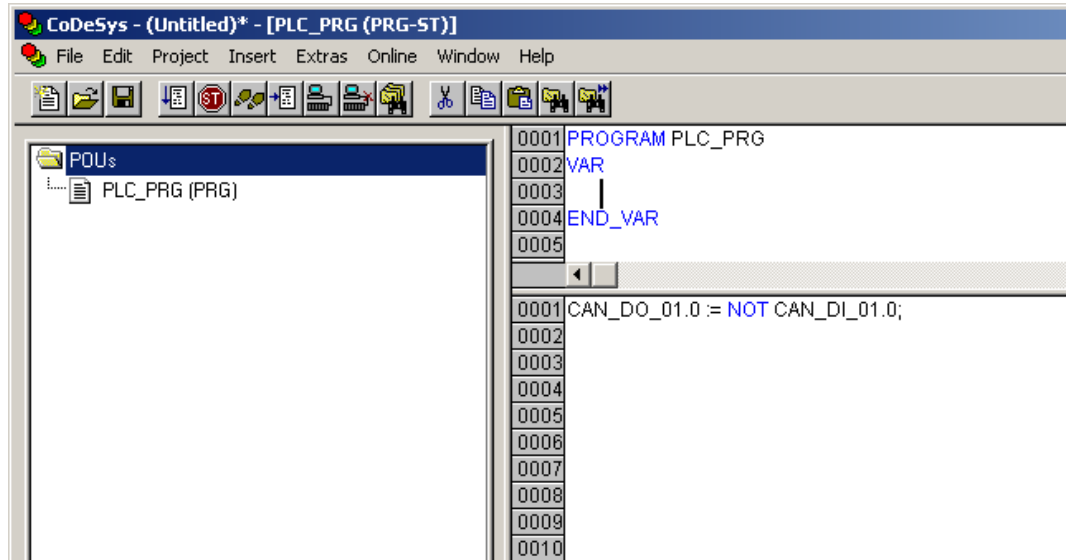

```
0001 PROGRAM PLC_PRG
0002 VAR
0003 |
0004 END_VAR
0005
0001 CAN_DO_01.0 := NOT CAN_DI_01.0;
0002
0003
0004
0005
0006
0007
0008
0009
0010
```

You can now load the project into the IPC and test the function. When the test program is running, the output will always be the opposite state of the input.

6 WAGOframe

WAGOframe is an FDT/DTM frame application for configuration, diagnosis and updating of FDT-compliant field devices.

FDT/DTM is a manufacturer-independent concept for setting of parameters for field devices from different manufacturers using only a single program. The phrase "Field Device Tool"(FDT) not only represents a concrete program, but also defines the interfaces that a program must deal with in order to cooperate with DTMs from different manufacturers.

A "Device Type Manager"(DTM) groups all the setting options for a field device (including graphic interfaces) into a single program that is executed in an FDT/DTM frame application. The specification makes a distinction between device DTMs, communication DTMs and gateway DTMs.

6.1 Installation

A browser-based wizard leads you through the installation of the required drivers, DTMs and programs. When performing an installation from the CD, the Internet browser used will open automatically to the following page:



1. When performing an installation from the file system switch to the directory "`~/WAGOframe CD-ROM_v3.0.0`" and open the file "`Deutsch_main.htm`".



2. To install all the required components, select "Series 767 + WAGOframe".

3. The following page will be displayed. Execute all five installation programs one after the other to install the configuration software.

WAGO - INNOVATIVE CONNECTIONS...

For the installation of the configuration software you accomplish please successively all five specified setup routines:

Visit our website
wago.com

WAGO
INNOVATIVE CONNECTIONS

+49(0)571/ 887 555
+49(0)571/ 887 8555
support@wago.com

 Install USB driver for devices serie 767...
[759-922 \(Version 1.2.3\)](#)

 Install WAGOFrame...
[759-370 \(Version 1.0.5\)](#)

 Install WAGO-Service-Interface DTM...
[759-371 \(Version 1.2.0\)](#)

 Install DTM Serie 767...
[759-361 \(Version 1.3.0\)](#)

Note



Installation of the USB driver 759-922 is not required if this driver has already been installed via "CoDeSys 3" setup. Any USB driver that is already installed will then be updated.

If an older version of "WAGOframe" is installed, this must first be de-installed with the installation routine. The same applies to DTMs.

The installation sequence for the individual components is always the same, beginning with language selection.



1. Continue by clicking [OK].

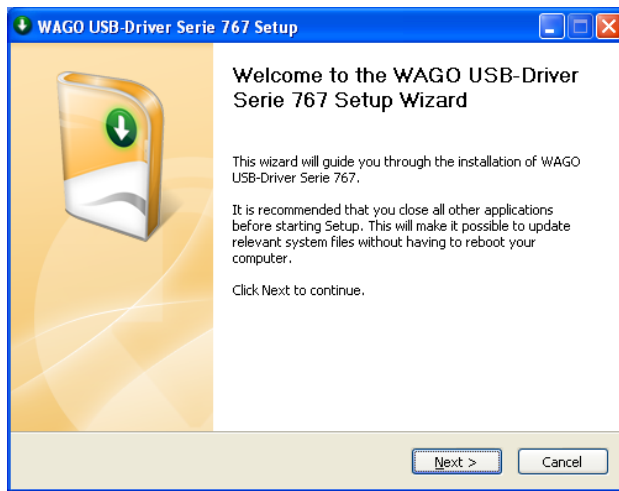

2. Continue by clicking [Next >].

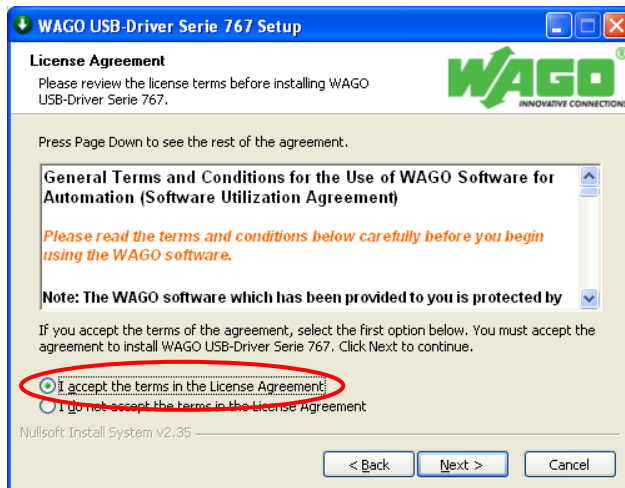

3. Read the Terms of Use for the WAGO USB driver before selecting "I accept...". Confirm this selection. Then click on [Next].

4. Check your personal settings.

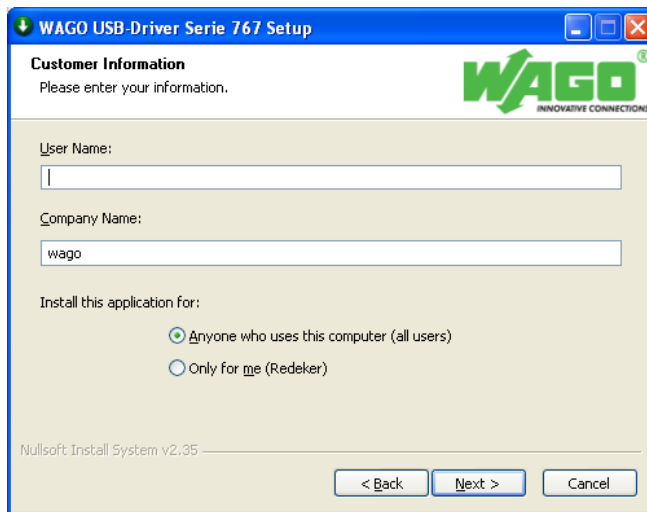

5. Continue by clicking [Next >].

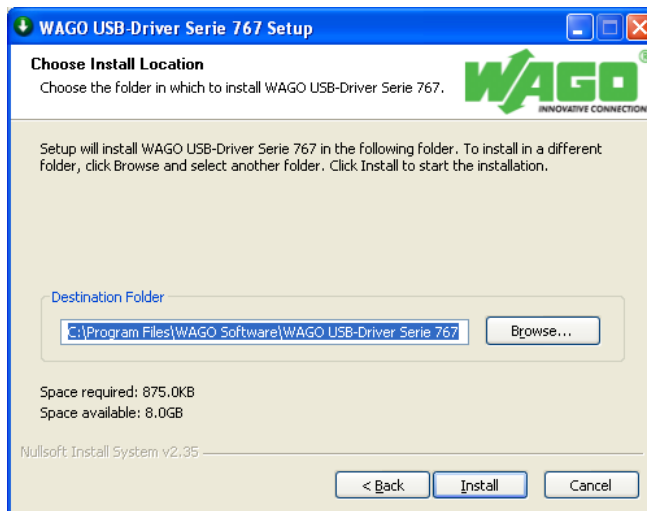

6. Select the installation path under which the application is to be saved.
7. Start the installation by clicking the [Install] button.



8. Continue by clicking [Next >].

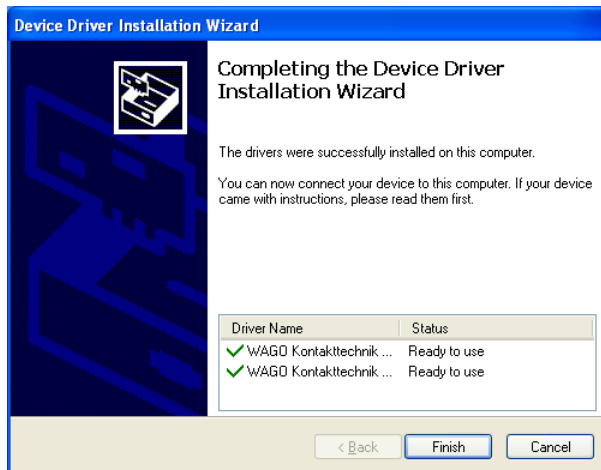

9. Complete the installation by clicking **[Finish]**.



10. Quit the wizard by clicking the **[Finish]** button.

Repeat these steps for the other four software components:

- WAGOframe: Item No. 759-370 (Version 3.0.0)
- WAGO service interface DTM: Item No. 759-371 (Version 2.1.0)
- DTM for the fieldbus coupler and I/O modules: Item No. 759-361 (Version 2.1.0)
- DTM for the system update: Item No. 759-362 (Version 1.0.0)

6.2 Starting Up the Fieldbus Coupler

Now switch on the power for the fieldbus coupler and link its service port to a free USB slot on your PC using the USB communication cable 756-4101/0042-0030.

Communication between WAGOframe and the fieldbus coupler is carried out via the communication DTM "WAGO Service Interface". The COM port that is used depends on the USB slot and must be parameterized accordingly in the WAGO Service Interface.

Note



If the fieldbus coupler is linked to a different USB slot at a later time, this will also result in a change to the COM ports used by "I/O-Service". In this case the setting for the serial interface must be adapted accordingly in the communication DTM.

6.3 Operation

Start the WAGOframe program using the icon on the desktop, or via **Start > Programs > WAGO Software > WAGOframe > WAGOframe**.



After starting you can select either the "Point to point mode" or the "Expert mode". The "Point to point mode" was developed specially for the configuration of simple devices (such as WAGO Jumpflex). Use the "Expert mode" to set parameters for the 767 components.

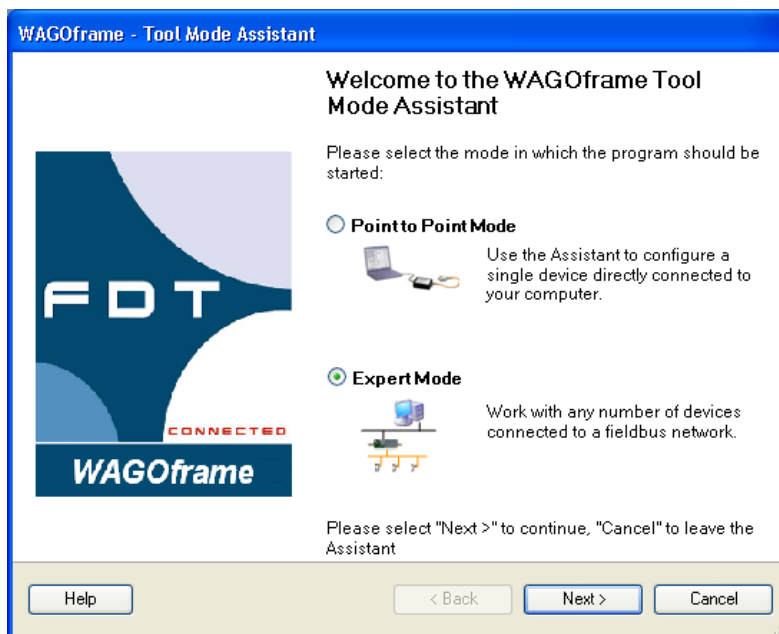

1. Switch to the "Expert mode" and click [Next >].

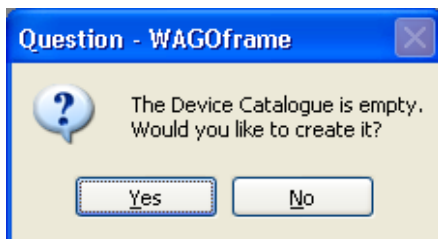

No device catalog will have been created on the initial call-up.

2. Click [Yes] in the dialog window that then appears to configure a device catalog on your PC.

3. In the window "Network view" mark the element "Network" and select the function **Add...** using the context menu (right mouse key). A dialog window then opens showing all available communication drivers.

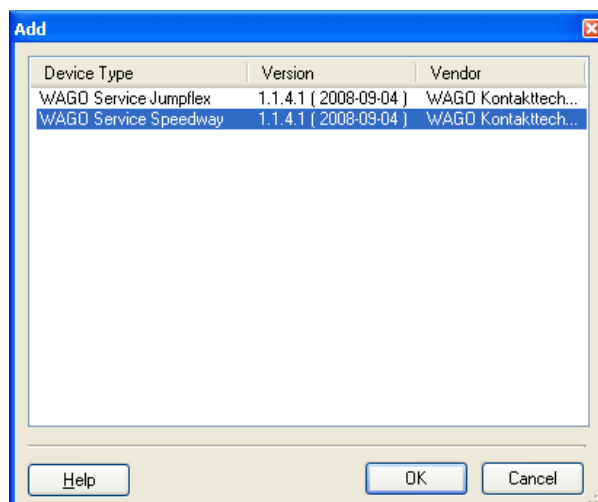
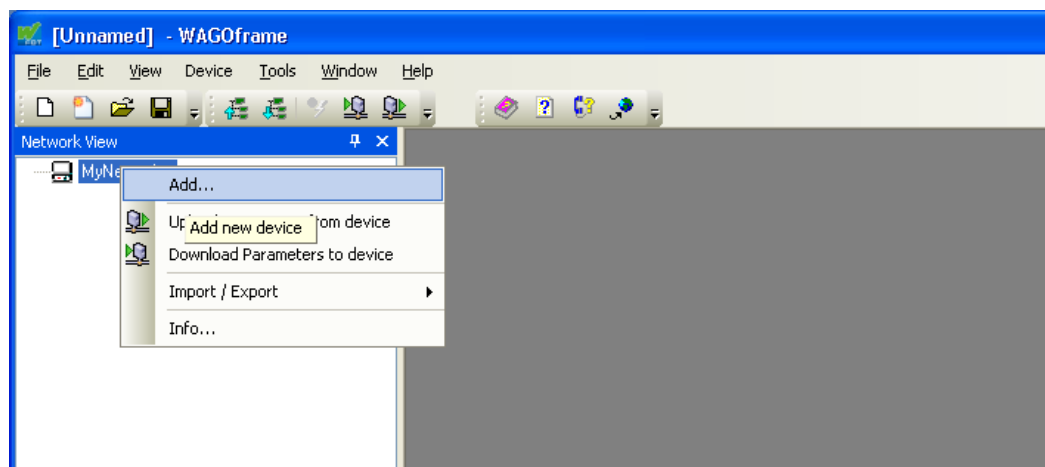

4. Select the "WAGO Service Speedway" communication driver and confirm your selection by clicking **[OK]**.
5. In the window "Network view" double-click on the newly added element "<->WAGO Service Speedway".

Setting the serial interface parameters for the "WAGO Service Interface" communication DTM.

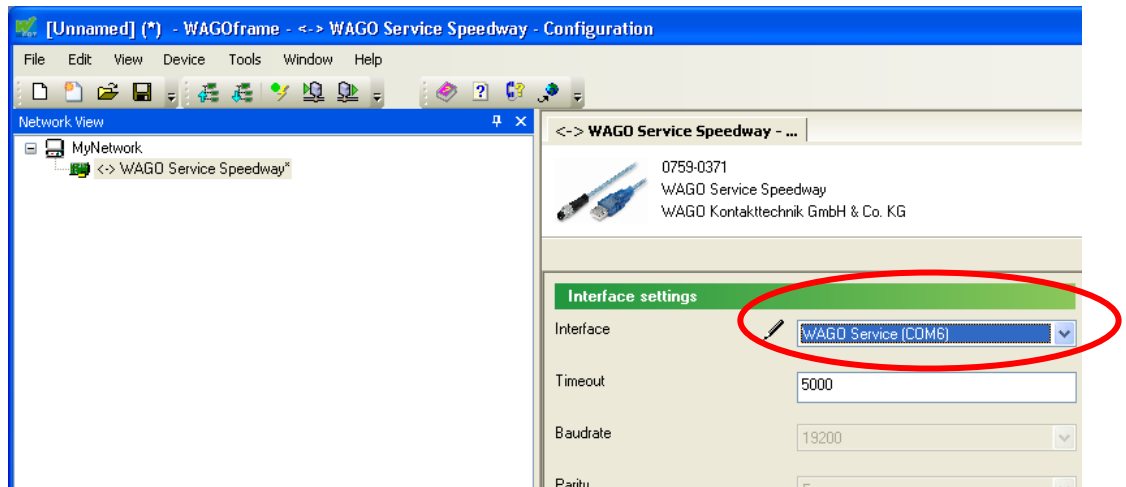

1. Select the interface to be used from the list and accept these settings.
If there are no entries in the list of available interfaces, check to ensure that the fieldbus coupler is switched on and that it is connected to your PC by the USB communication cable.
2. To complete the network configuration you can now select individual DTMs from the catalog, or conduct a network scan.

When adding elements manually please note that each FDT frame application differentiates between online and offline modes. Each of these modes has a separate scope of functions.

In the online mode, there is a direct link between the display and the connected 767 components.

The offline mode enables the parameterization of a device that is not yet present. It will continue to be used to reduce data transfer between WAGOframe and the device. If a device is in the online mode, its name is displayed in ***bold and cursive*** font in the network window.

- To conduct a network scan, open the context menu (right mouse key) of the element "WAGO Service Speedway" in the "Network" window and then select the entry **Create network** under the menu item **Scan**.

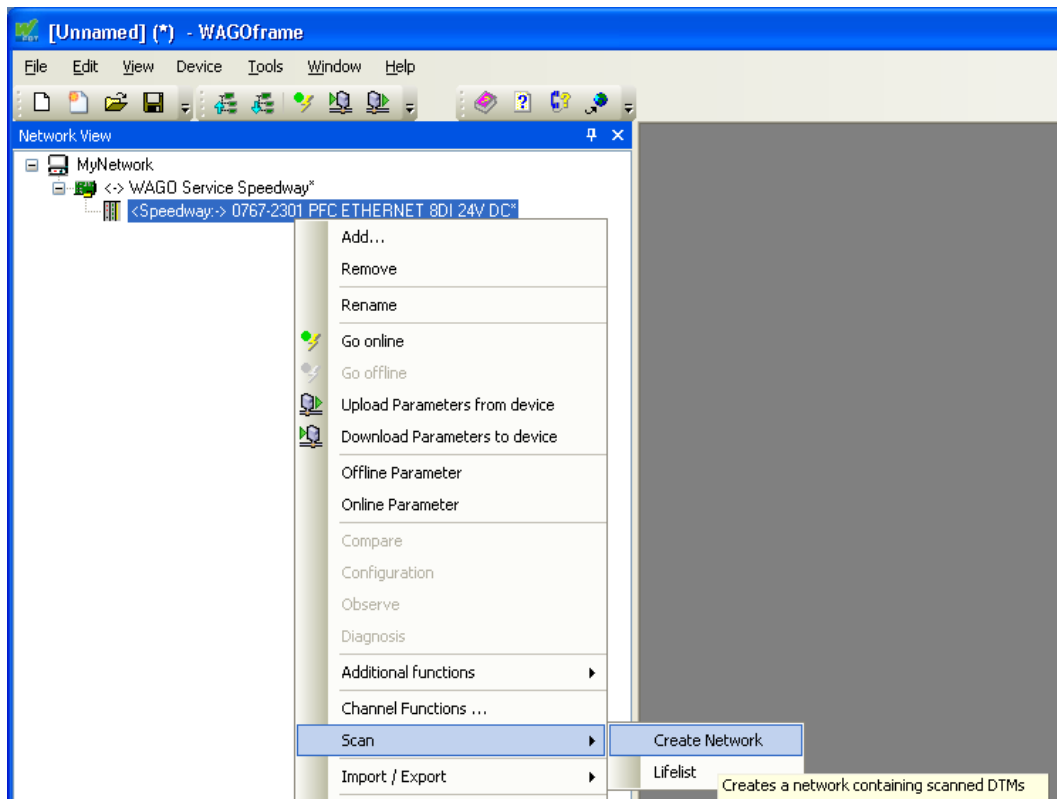

- After performing a network scan, WAGOframe should have found the fieldbus coupler and the connected modules .
- A "Live List" is created if no matching DTM is found for the fieldbus coupler when scanning the network. Click on **[Add all and continue]** in the list.



- Note that the fieldbus coupler is in the online mode, while the module is in the offline mode. Mark module and select the entry **[Go online]** from the context menu to switch to the online mode.

7. Open the detail view by double-clicking the fieldbus coupler. WAGOframe should appear as follows after editing the window width and closing the device catalog:

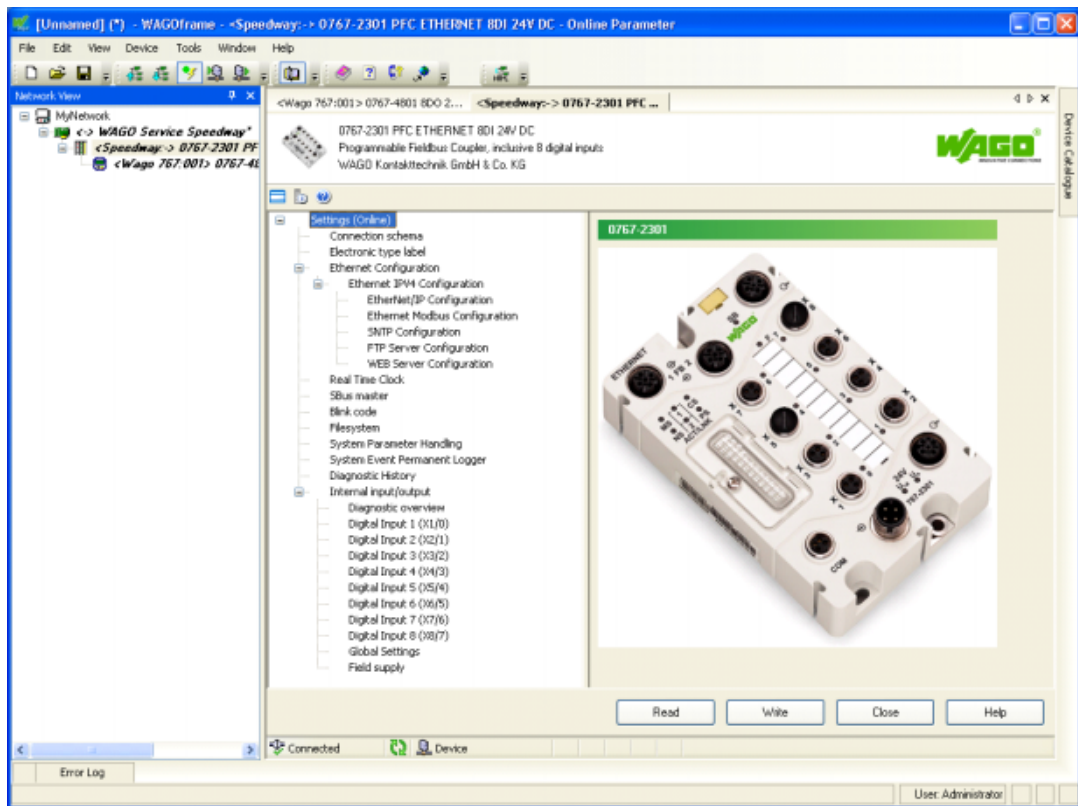

The current operating mode is shown in brackets behind the first node of the tree structure (left window). Please note that changing between operating modes is only possible when the detail window concerned is closed.

Explanations of the buttons:

- Read:
Reads and displays the parameters found in the fieldbus coupler.
- Write:
Writes the modified values to the fieldbus coupler.
- Close:
Closes the parameterization user interface (DTM).
- Help:
Opens the online help for an entry selected previously (e.g., digital input, blink code).

7 System Update

Firmware update for the 767 Series components is performed via system update. To ensure that the fieldbus node remains consistent and executable after updating the firmware, system update must be performed for both fieldbus coupler and connected I/O modules.

NOTICE

System update

Before updating, observe the following measures to prevent any possible damage to the 767 system:

- The power supply must not be disconnected while updating!
 - To exclude any interferences by the fieldbus, the fieldbus cable must be disconnected before updating!
-

Requirement:

- You have installed the DTM (759-370) WAGOframe
- You have installed the DTM (759-371) WAGO service interface
- You have installed the DTM (759-922) USB driver
- You have installed the DTM (759-362) system update.
- Update packages are available for the connected 767 Series components.

System Update Procedure

To perform a system update for each 767 Series component, please complete the following steps:

1. Read 767 components' parameters and save them on your PC.
2. Update 767 Series components' firmware.
3. Rewrite parameters from your PC to the 767 Series components.
4. Set parameters to valid and finish the procedure.

7.1 Adding the DTM System Update

To add the DTM system update to WAGOframe, please proceed as follows:

1. In "Network View", right-click on the "WAGO Service Speedway" device driver.
2. In the **Add...** context menu, select "Add". The "Add" dialog box opens.

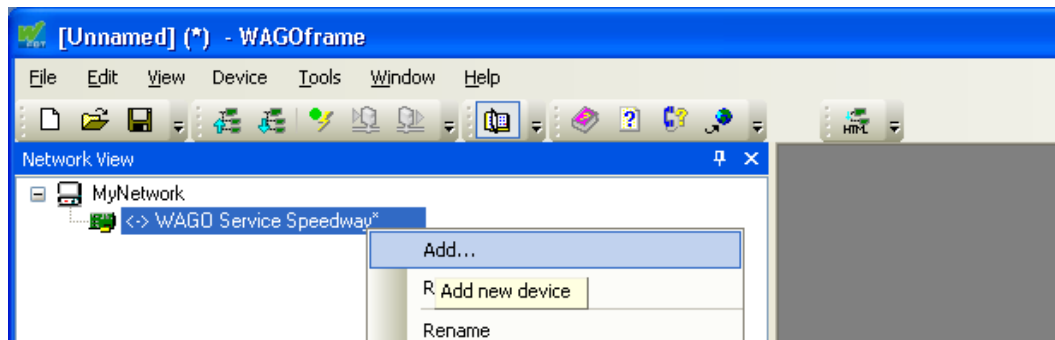
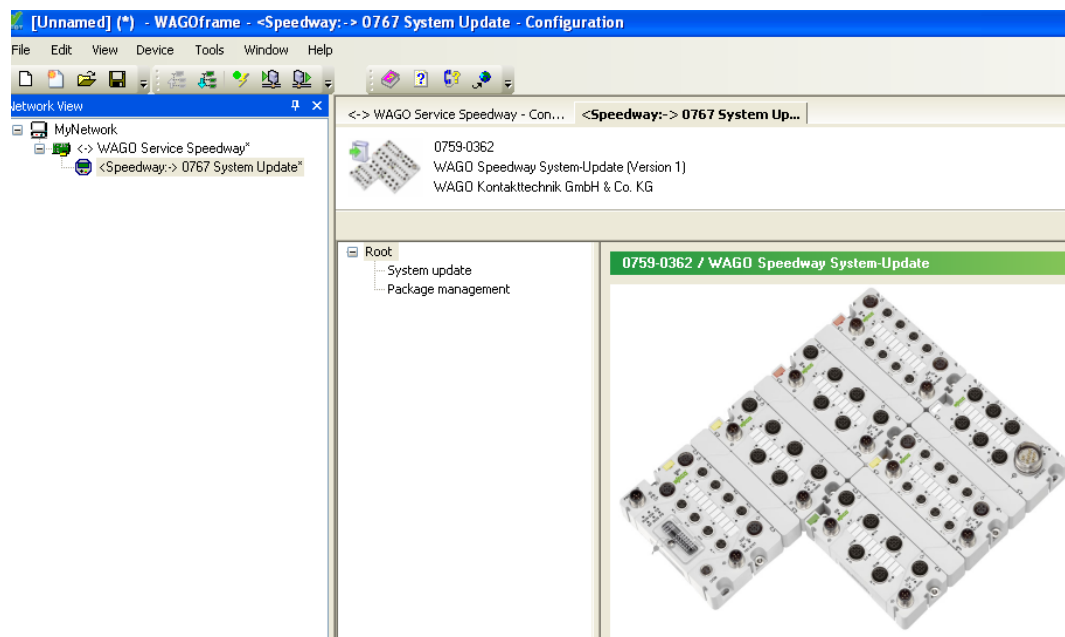

Figure 1: Adding the DTM system update

3. In the "Add" dialog box, select the **DTM 0767 System Update**.
4. Click **[OK]** to confirm your selection.



7.2 Go online to 767 Nodes using Update DTM

The firmware can only be updated when a communication connection exists between Update DTM and 767 node. Please proceed as follows:

1. In the "Network View", right-click on the "<Speedway:-> 0767 System Update" device driver.
2. In the context menu, select **Go online**. When the progress bar displays 100% and the entry is displayed in *bold italics*, the communication connection is established.

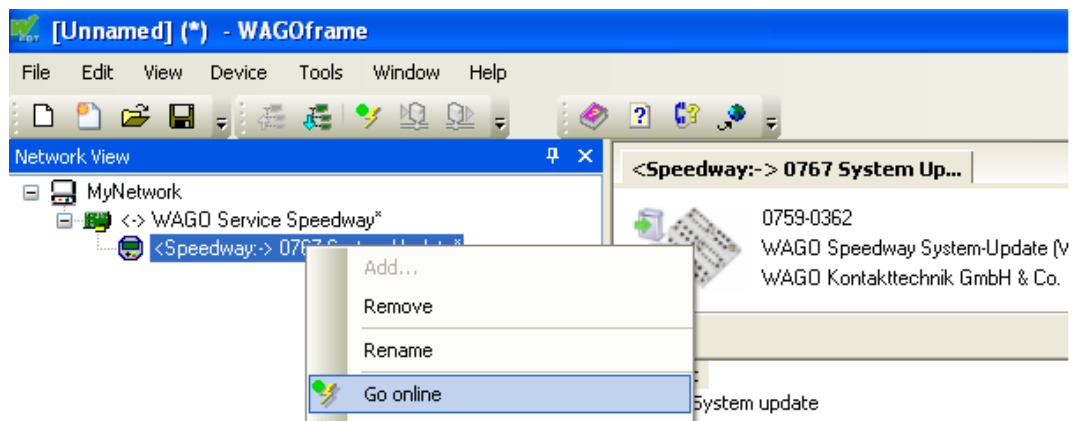

7.3 Updating the 767 Components

The current firmware is available from WAGO Support. Send an e-mail with the subject "Current Speedway Firmware" and the item number of the respective 767 components to: support@wago.com.

Import firmware packages

To use the received firmware packages, import them into the DTM system update. Please proceed as follows:

1. Save the received firmware packages with the ".wup" extension to any directory on your PC.
2. Open the DTM user interface by double clicking "**0767 System Update**" in the network view.

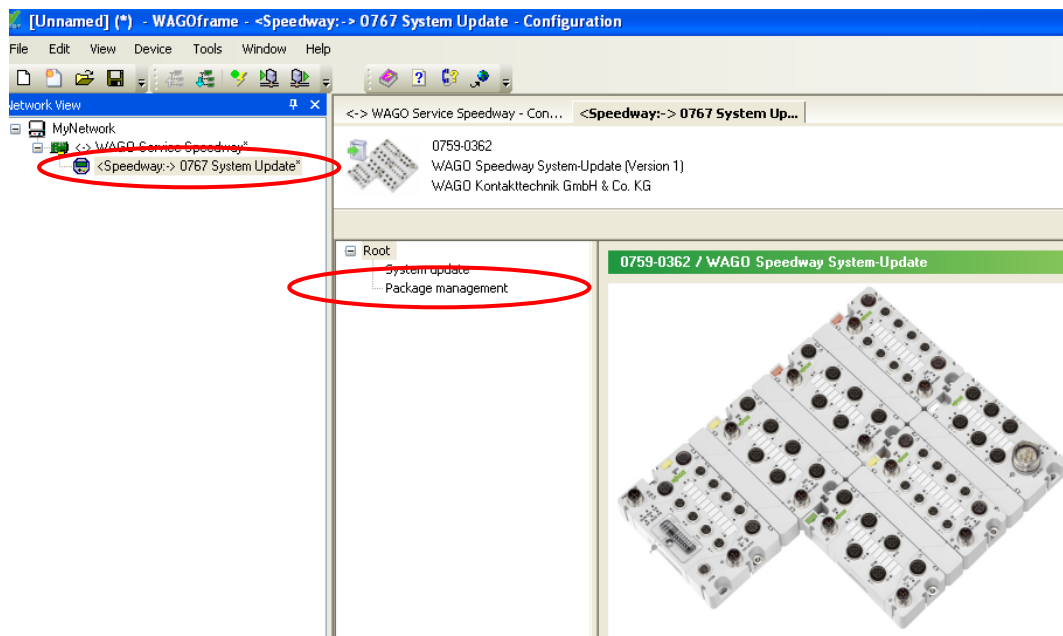

3. Click "Package Management" in the left window of WAGOframe.
4. To import the received firmware files, click **[Import]**. In the window that opens, go to the directory where you have saved the firmware files and select the file to be used. Click **[Open]** to apply the files.

Delete firmware packages

To maintain a clear "Package Management" interface, you can remove unneeded update packages from the view. Please proceed as follows:

1. Select the required firmware files in the right window.
2. Click [**Delete**] to remove the selected firmware packages.

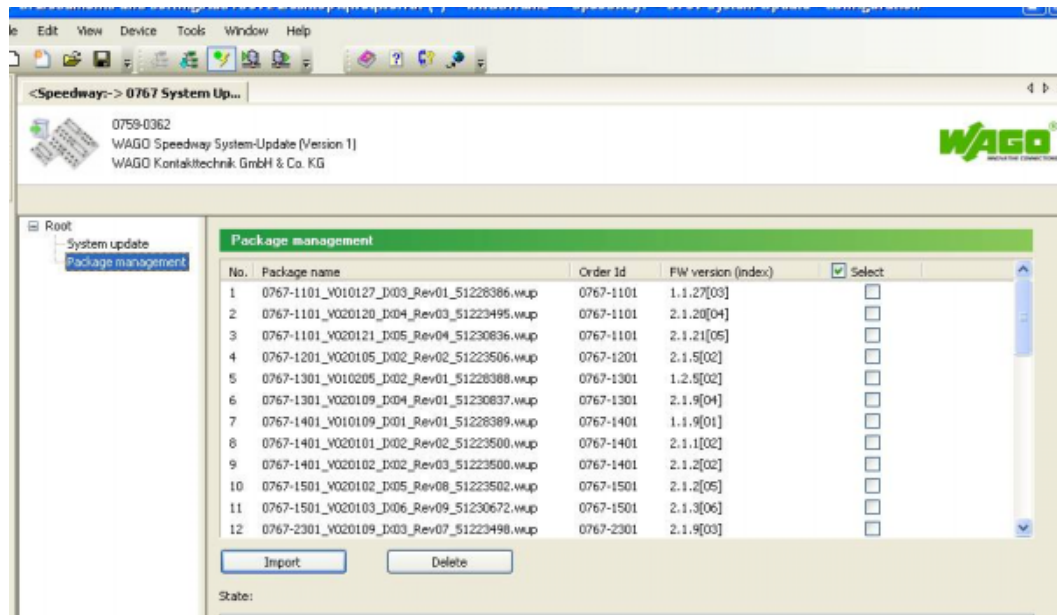

System update



Note

When updating the firmware of the fieldbus coupler, the saved module parameters may be overwritten. Therefore, check your existing configuration after updating the firmware.

Perform the system update here. The module settings you made normally remain unchanged. Otherwise, a corresponding warning message appears. If you still want to update the firmware, the 767 components are returned to their default state.

1. Click "System Update" in the left window.

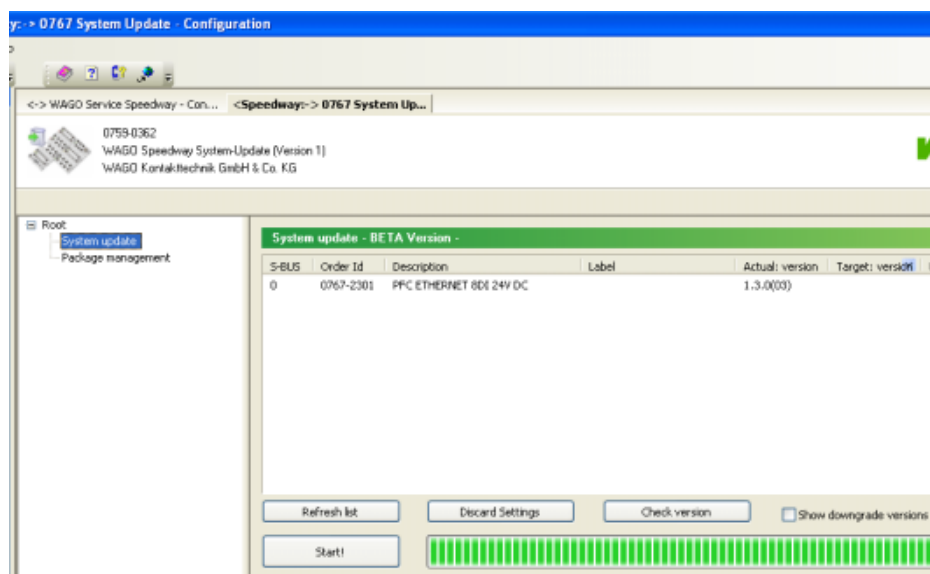

2. The fieldbus coupler with all connected I/O modules are listed in the right window. All 767 components that can be updated are pre-selected. If the pre-selection is incorrect or if specific 767 components should not be updated, deselect them.

"Actual: Version": Firmware currently present on the device

"Target: Version": Version of the firmware that should be loaded into the 767 components. If multiple "Target" versions can be selected, select the one relevant to you.

- Click **[Start!]** to update the system. The 767 components are marked in yellow while being updated.

Note



During the firmware updating process, the fieldbus coupler disconnects each of its COM ports. A PC equipped with Windows 2000 will detect this, and a Windows message appears. This is not an error message. Confirm the message by pressing **[OK]**.

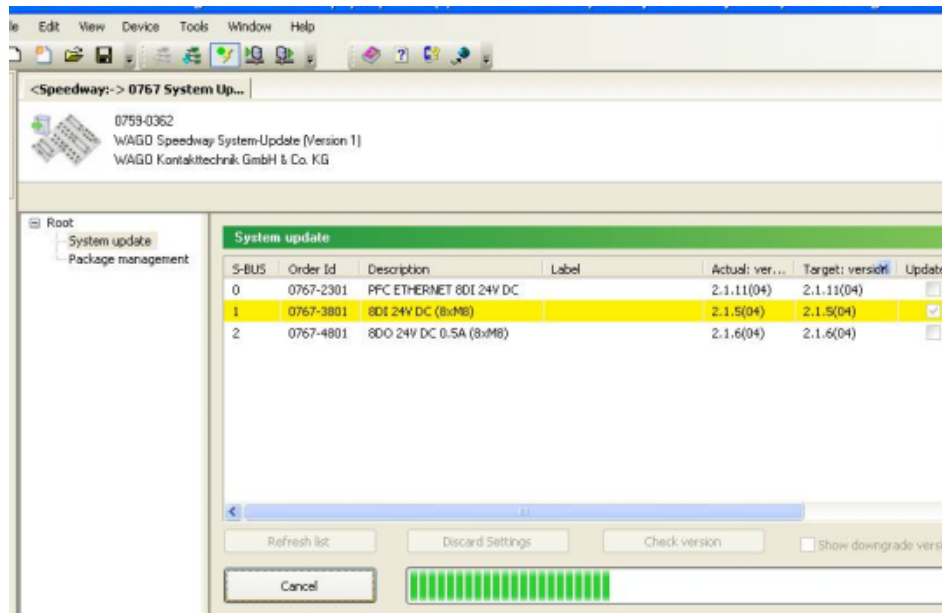

Button	Description
[Update List]	Use this function to read the node design and the view updates.
[Discard Settings]	Discard the selections and settings performed by you.
[Check Versions]	If you made your selection, click this button to perform a plausibility check. This checks whether the configuration you selected is possible (also automatically performed when starting the system update).
Display downgrade versions	If this checkbox is selected, the versions to downgrade a device are also displayed in the list of target versions.
[Start!]/[Abort]	Start/abort system update.

4. If the system update is finished, the updated 767 components are displayed in green (see figure).

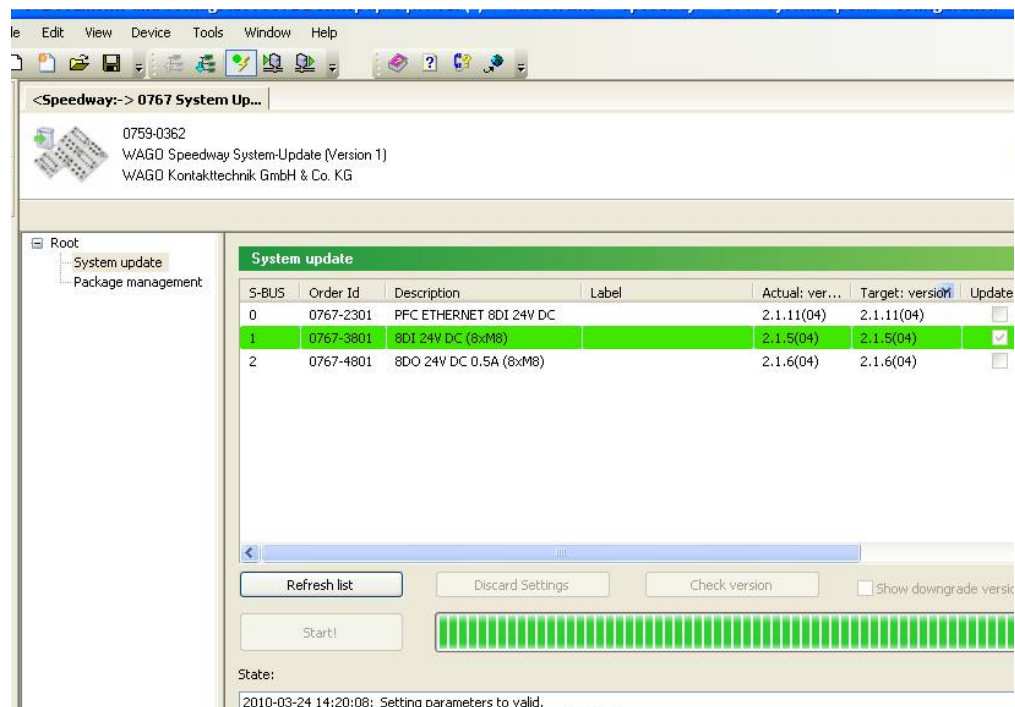

During system update, all relevant information is stored on your PC. Update can be repeated subsequently if the system update fails (components are displayed in red). In this case, original parameters remain unchanged.

If the update for a device fails, please contact WAGO Support.

Information

Further information is given in the WAGOframe manual.



WAGO Kontakttechnik GmbH & Co. KG
Postfach 2880 D-32385 Minden
Hansastraße 27 D-32423 Minden
Telefon: 05 71/8 87 – 0
Telefax: 05 71/8 87 – 1 69
E-Mail: info@wago.com

Internet: <http://www.wago.com>

