

WAGO SPEEDWAY 767

ETHERNET, 8 DI, 24 V DC

767-2301

Programmable Fieldbus Coupler

Version 2.0.0

Introduction

Every conceivable measure has been taken to ensure the accuracy and completeness of this documentation. However, as errors can never be fully excluded, we always appreciate any information or suggestions for improving the documentation. E-mail: documentation@wago.com

Service and Technical Support

Additional information regarding this and other products (e.g., data sheets) is available on our website www.wago.com.

If you can not eliminate errors or faults using the measures described in this manual we will be glad to assist you further. Contact us at:

AUTOMATION Support
Phone: +49 571 887 555
Fax: +49 571 887 8555
E-mail: support@wago.com

Additional Support

The Seminar and Training department offers useful seminars to support you in the use of WAGO products. For more information, visit our website or call +49 571 887-327, or send an e-mail to training@wago.com.

Trademarks

We wish to point out that the software and hardware terms as well as the trademarks of companies used and/or mentioned in the present manual are generally protected by trademark or patent.

Table of Contents

Introduction	2
1 Safety	4
1.1 Notes on This Quick-Start Guide	4
1.2 Explanation of Symbols	5
1.3 Validity of This Quick-Start Guide	7
1.4 Use in Compliance with Underlying Provisions	7
1.5 Personnel Qualification	7
1.6 Basic Safety Information	8
1.7 Safety Equipment	9
1.8 Technical Condition of the 767 Components	10
1.9 Notes on Operation	10
2 Description	11
2.1 Accessories	11
3 Connection	13
4 CoDeSys 3	18
4.1 Installing CoDeSys	18
4.2 Editing the Gateway Configuration	26
4.2.1 Identifying Assigned COM Ports:	27
4.3 Your Initial CoDeSys 3 Project	28
4.3.1 Adding IO Modules	30
4.3.2 Creating Output Variables	31
4.3.3 Adding Instructions	32
4.3.4 Setting Communication Parameters	33
4.3.5 Logging In and Starting the Application	35
4.3.6 Creating a Boot Project and Activating the Automatic Start	36
5 Ethernet Port	37
5.1 IP Address Allocation	37
5.1.1 Allocation of a Set IP Address using DIP Switches	38
5.1.2 Allocation of a Dynamic IP Address using BootP	39
5.1.3 Testing the Network Connection	42
5.2 User Administration	42
5.3 File System	43
5.3.1 Access via FTP	43
5.4 Web-Based Management (WBM)	44
6 WAGOframe	46
6.1 Installation	47
6.2 Starting Up the Fieldbus Coupler	52
6.3 Operation	53
7 System Update	58
7.1 Adding the DTM System Update	59
7.2 Go online to 767 Nodes using Update DTM	60
7.3 Updating the 767 Components	61

1 Safety

1.1 Notes on This Quick-Start Guide

The programmable fieldbus coupler shall only be installed and operated in conjunction with these quick-start instructions and the system description. Detailed information on the programmable coupler is provided in the 767-2301 manual.

WARNING

Observe release notes!

Please note that, within the SPEEDWAY system, a function is provided **without restriction** only if all system's components have the same system-wide firmware release. Therefore, always observe the appropriate release notes on products used.

NOTICE

Supply layout!

In addition to these operating instructions, you will need the "WAGO SPEEDWAY 767, System Description and Information" manual, which can be downloaded at www.wago.com. There you will find information regarding supply layout, etc.

1.2 Explanation of Symbols

**DANGER****Warning of physical injury**

Indicates a direct hazard with a high level of risk which leads to death or serious physical injury if not avoided.

**DANGER****Warning of physical injury from electric current**

Indicates a direct hazard with a high level of risk which leads to death or serious physical injury if not avoided.

**WARNING****Warning of physical injury**

Indicates a possible hazard with a moderate level of risk, which may lead to death or (serious) physical injury if not avoided.

**CAUTION****Warning of physical injury**

Indicates possible hazards with a low level of risk, which could lead to minor or moderate physical injuries if not avoided.

NOTICE**Warning of damage to equipment**

Indicates a possible hazard that could lead to equipment damage if not avoided.

NOTICE**Warning of damage to equipment from electrostatic discharge**

Indicates a possible hazard that could lead to equipment damage if not avoided.

Note



Please note

Indicates possible malfunction, which does not lead to equipment damage if it is not avoided.

Information



Reference to additional information

Indicates other sources of information which are not an integral part of this documentation, such as the Internet.

1.3 Validity of This Quick-Start Guide

These operating instructions are only applicable to the positive-switching WAGO SPEEDWAY 767 Series programmable fieldbus coupler, item number 767-2301. In this manual, the programmable fieldbus coupler will be referred to hereafter as simply the fieldbus coupler.

1.4 Use in Compliance with Underlying Provisions

The EtherNet/IP fieldbus coupler provides digital process data from digital and analog I/O modules. The data is gathered by the fieldbus coupler and made available to a higher-level controller for further processing.

The fieldbus coupler shall not be used to control safety-related functions; i.e., emergency-off devices shall not be operated with this fieldbus coupler.

The fieldbus coupler shall only be used as a unit or in combination with I/O modules from the WAGO SPEEDWAY 767 Series.

The fieldbus coupler was developed for applications requiring IP 67 (NEMA type 6, 6P) protection.

The fieldbus coupler is expandable by a maximum of 64 I/O modules from the WAGO SPEEDWAY 767 Series.

Applications other than those described in this manual are not permitted.

1.5 Personnel Qualification

All sequences implemented on the fieldbus coupler may only be carried out by electrical specialists with sufficient knowledge in automation. The specialists must be familiar with the current standards and guidelines for the fieldbus coupler and automation environment.

All changes to the controller should always be carried out by qualified personnel with sufficient sufficient skills in PLC programming.

1.6 Basic Safety Information

This section contains a summary of the most important warnings, which are also repeated in the individual sections. They serve as a protection to your health and a protection from equipment damage on the 767 Series components (fieldbus coupler and the I/O modules connected to it). Read and adhere to the following safety precautions before using the fieldbus coupler.



DANGER

Electric voltage!

Operate the 767 Series components exclusively with 24VDC PELV (Protective Extra Low Voltage) or SELV (Safety Extra Low Voltage) voltage sources. Failure to comply may result in electric shock.

CAUTION

Hot connection sockets!

Even when taking into account derating, high surface temperatures on the metallic connection sockets and on the enclosure can arise during operation. If the 767 Series component has been in operation, allow it to cool off before moving it.

NOTICE

The highest current carrying capacity of the supply contacts is 4A!

Always observe the maximum current carrying capacity per supply line (U_{LS} , U_A) for each 767 Series component and the overall power consumption for all 767 Series component. Neither of these values shall exceed 4A since an increase in current causes the contacts to overheat and damages the 767 Series components. Information regarding the power demand of each 767 Series component can be found in the corresponding data sheet, which is available from www.wago.com.

NOTICE

Exposed connections!

If connections have not been closed with protective covers, liquid or dirt can penetrate the fieldbus coupler and ruin it. Close all unneeded connections with protective caps to ensure that IP 67 degree of protection is provided.

- Disconnect the power supply from the system on which you wish to mount the 767 Series component.
- Always keep the cover cap of the DIP switch closed.
- Observe the appropriate accident prevention regulations for your system during assembly, startup, maintenance and repairs.
- The operating instructions of the 767 Series components and the system description must be readily available at the workplace.

- Observe the exact positioning (coding) between plug and socket.
- The 767 Series component shall not come in contact with substances having seeping and insulating properties. Otherwise, additional measures shall be taken for the devices, such as installation of an enclosure that is resistant to the above-mentioned substance properties.
- Electronic components fulfilling the ESD requirements according to the IEC 61000-6-2 are integrated in the 767 Series component. Since, under unfavorable circumstances, higher voltages may also occur due to electrical charge in the field, discharge must be ensured before performing work on the 767 system.
- Observe the correct layout of the potential equalization.
- Keep all cables a sufficient distance away from electromagnetic sources of interference in order to maintain a high level of interference resistance of the 767 system against electromagnetic emissions. Use only shielded cables at the necessary locations, and always observe the appropriate standards for EMC-suitable installations.
- For the power supply and for the S-BUS, use only pre-assembled WAGO system cables, so the specified characteristics of the technical data can be achieved.
- Replace defective or damaged 767 Series component (e.g., deformed connections), else function disruptions can occur in the respective fieldbus stations or nodes.
- When laying any cables, make sure that you do not lay them within the shear range of movable machine parts.
- For each activity, observe the corresponding personnel qualification in Section 1.5.
- Observe the marking on the front and rear side of the 767 Series component.

1.7 Safety Equipment

All 767 Series products are designed according to the IP 67 safety class. This consists of, among other things, complete touch protection of electric voltages and currents – even when wet.

1.8 Technical Condition of the 767 Components

If any change is made to the 767 Series components or software and firmware without the written approval of WAGO Kontakttechnik GmbH & Co. KG, all liability claims are nullified.

1.9 Notes on Operation

When integrating the 767 Series components in your machine or system, all the currently applicable norms, regulations and guidelines shall be observed during all activities. The emergency stop equipment shall remain effective in all operating modes of the system and machine.

For protection from electromagnetic interferences

- Connect your system to protective earth (PE), and
- Ensure that the cable routing and the installation of the fieldbus cable, S-BUS cable, supply cable, and sensor cable are correct.

The following elements for 24V supply shall be present:

- Outer lightning protection on buildings
- Inner lightning protection of supply lines and signal lines
- Safe electrical separation of low voltage 24VDC through PELV (Protective Extra Low Voltage) or SELV (Safety Extra Low Voltage) voltage sources

2 Description

This quick-start guide describes the most important steps for starting the fieldbus coupler, up to creation of an initial CoDeSys 3 application.

Section 3 deals with wiring for the fieldbus coupler. Details about installation and configuration of the " CoDeSys 3.3 SP2 Patch1 Hotfix2" development environment are given in Section 5.1. Section 5.3 explains how to create an initial CoDeSys 3 project and load it to the control system. Section 6 deals with services for the Ethernet interface, while Section 7 provides a brief introduction to the FDT/DTM configuration software "WAGOframe". Information on the system update can be found in Section 8.

2.1 Accessories

This manual was created using the following software and hardware:

Name	Description	Version
CoDeSys 3	IEC-61131 Programming Environment	3.3 SP2 Patch1 HF2

Name	Description	Item no./Version
WAGOframe CD-ROM Ver. 3.0.0	FDT/DTM frame application	759-370 Ver. 1.0.8
WAGO USB driver	USB driver for 767 Series	759-922 Ver. 1.3.2
WAGO service interface DTM	DTM for communication	759-371 Ver. 2.1.0
WAGO DTM for fieldbus coupler and I/O modules	Device DTM for 767 series (programmable) fieldbus coupler and I/O modules	759-361 Ver. 2.1.0
System update DTM	DTM for firmware update	759-362 Ver. 1.0.0
Programmable fieldbus coupler	PFC EtherNet 8DI, 24 V	767-2301 Firmware: 2.1.11
Digital output module	8DO, 24V DC 0.5A (8xM8)	767-4801
USB communication cable (WAGOframe, CoDeSys 3)	M8 plug, straight	756-4101/ 0042-0030
Ethernet cable (D coded), with one end of the cable fitted	M12 right angle plug, 2 m	756-1202/ 0060-0200

Name	Description	Item no./Version
Ethernet plug	RJ-45, IP 20	750-975
S-BUS cable (B coded) with both ends of cable fitted	M12 socket, right angle, M12 plug, right angle, 0.2 m	756-1306/ 0060-0002
S-BUS terminating plug (B coded)	M12 plug, straight	756-9409/ 0060-0000
Power supply cable (A coded), both ends of cable fitted	M12 socket, right angle, M12 plug, right angle, 0.2 m	756-3106/ 0040-0002

When placing an order, also take into account an additional power supply cable between the power supply unit and the fieldbus coupler, in addition to the number of I/O modules needed.

3 Connection

NOTICE

Exposed connections!

If connections have not been closed with protective covers, liquid or dirt can penetrate the fieldbus coupler and ruin it. Close all unneeded connections with protective caps to ensure that IP 67 degree of protection is provided.

Then tighten the connector by hand when power is switched off. Using mechanical means to tighten it may strip the threads. In such a case, the fieldbus coupler is to be replaced.

Tightening torques for the connectors: 0.6 Nm

Wire the 767 components as shown in the following figure:

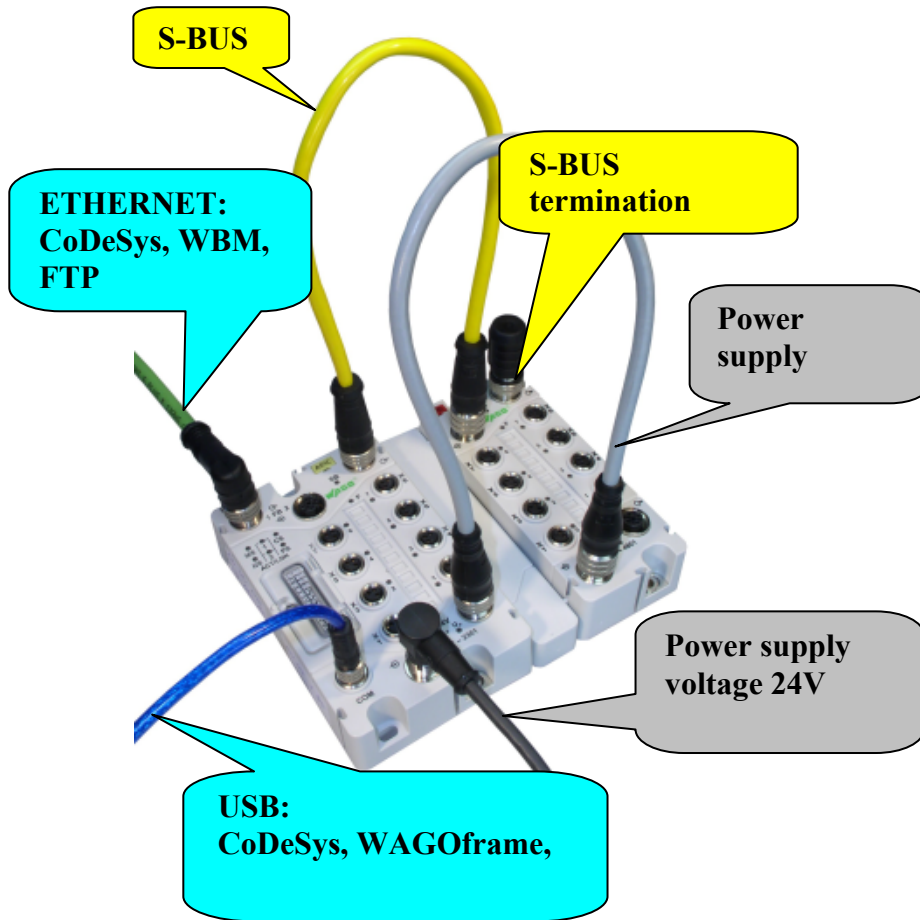

Supply voltage (M12 connectors, A coded, 4 poles):

Power supply feed-in for logic circuits and outputs is provided via separate contacts.

Connection		Contact	Description
		1	24VDC U_{LS}
		2	24VDC U_A
		3	0V U_{LS}
		4	0V U_A

Ethernet:

Connect the Ethernet cable fitted at one end as follows to implement a patch cable for use at a switch or a hub:

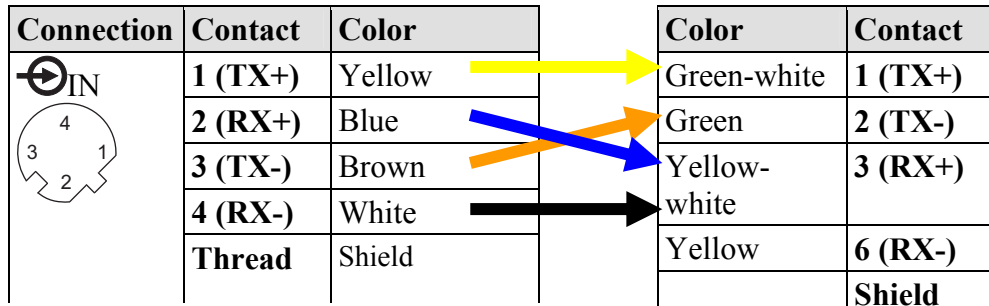

Connect TX to RX to implement a crossover cable for use with a PC.

S-BUS:

The system bus is used for internal communication between the fieldbus coupler and the 767 Series I/O modules connected to it.

Connection	Contact	Description
	1	TD +
	2	TD -
	3	RD -
	4	RD +
	5	0VDC
	Connecting thread	Shielded

Service port (USB):

The fieldbus coupler provides the following services at the service port:

- I/O-Service
The function "I/O-Service" is used by the FDT/DTM frame application "WAGOframe" to assign parameters to and configure the fieldbus coupler.
- I/O-Programming
This function is required for serial communication between the CoDeSys 3 development environment and the fieldbus coupler.

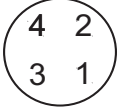
Connection	Contact	Description
IN 	1	+ 5V
	2	- Data
	3	+ Data
	4	0VDC
	Connecting thread	Shielded

The USB Speedway device driver is part of the installation programs of the "WAGOframe" application. For more information, see Chapter 6.1. The USB driver is installed together with the installation of CoDeSys 3 via "CoDeSys 3" setup.

Digital inputs:

The sensor cables provide power to the connected sensors and transfer the sensor signals. The table below outlines the connection assignments for the sensor connections:

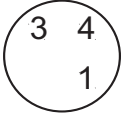
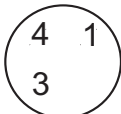
Connection		Contact	Description
IN	IN	1	24VDC (supplied from U _{LS})
 X1, X3, X5, X7	 X2, X4, X6, X8	3	0VDC
		4	Input

NOTICE

The highest current carrying capacity of the supply contacts is 4A!

Ensure that the sensors from the U_{LS} supply line are supplied with power. The sensor's power consumption is to be taken into consideration when determining the present power demand for the U_{LS} supply line.

NOTICE

The total maximum power consumption of the sensors must not exceed 400mA (50mA/channel).

Please note that the combined power consumption of all connected sensors is not to exceed 400mA. The distribution of power among the existing connections is depending on the individual power requirements of the sensors.

4 CoDeSys 3

4.1 Installing CoDeSys

CoDeSys 3 is based on Microsoft Plug-In technology, whereby different versions (profiles) of CoDeSys can be installed in one directory. During initial installation, Microsoft Framework 2.0 and all plug-ins associated with this version (profile) are also installed.

For subsequent installations, merely a new profile is created and any new plug-ins registered.

1. Start the installation program
" Setup_CoDeSysV33SP2Patch1Hotfix1.exe".

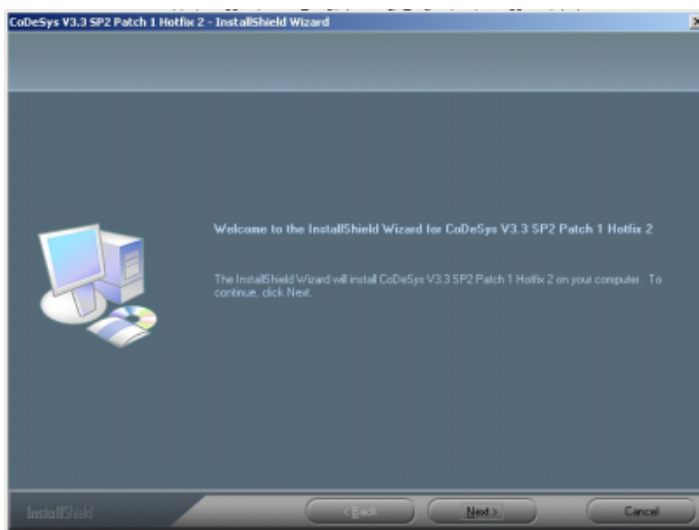

2. Continue by clicking [Next >].

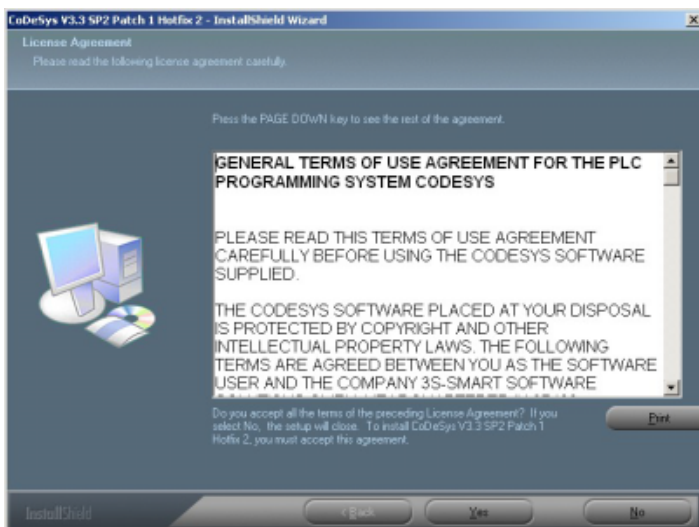

3. Agree to the license agreement by clicking on [Yes].

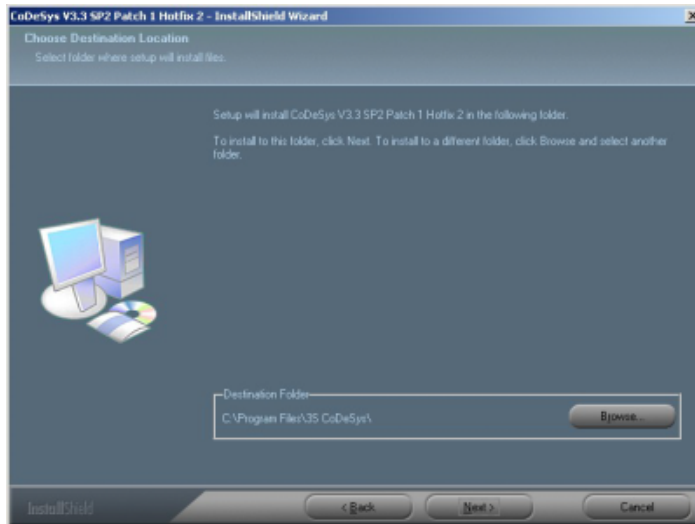

4. Click [Next >].

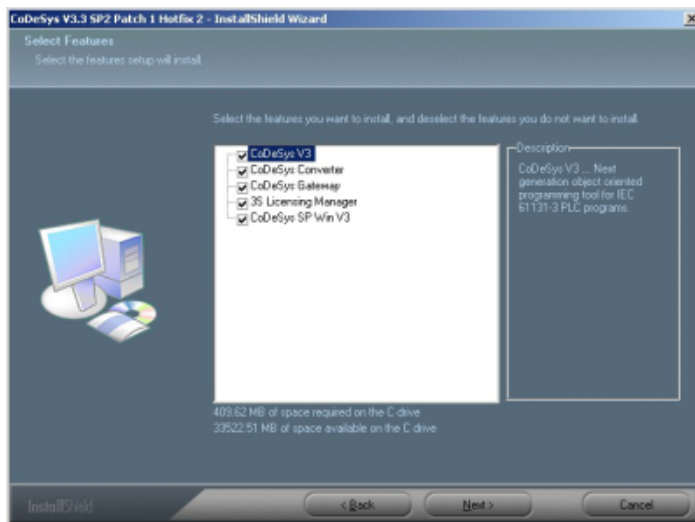

5. Click [Next >].

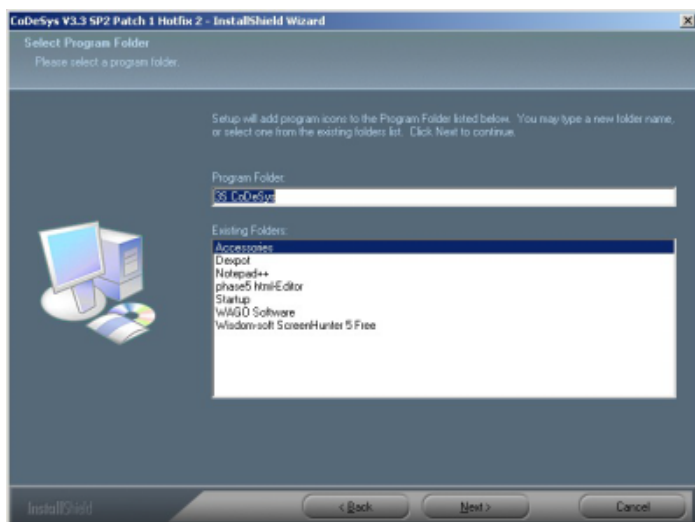

6. Click [Next >].

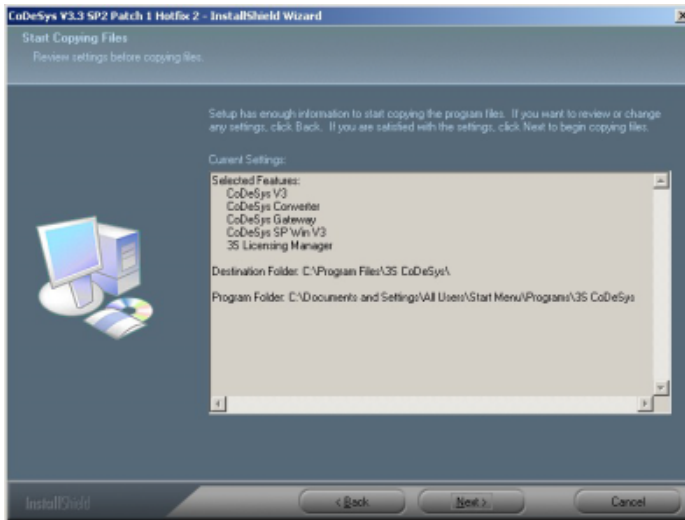

7. Click [Next >].

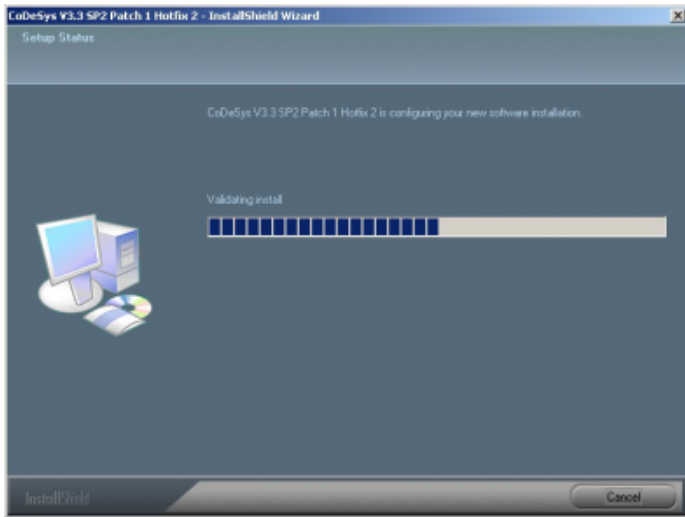

Starting the installation of WAGO-specific add-ons (e.g., USB driver, device description, libraries and templates).

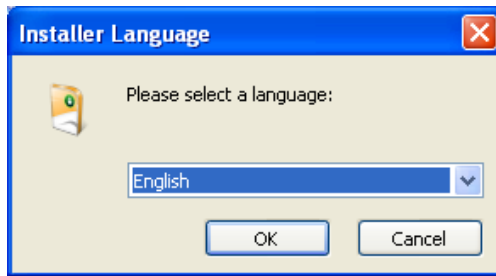

1. Select the language and continue with installation by clicking [OK].



2. Click [Next >].

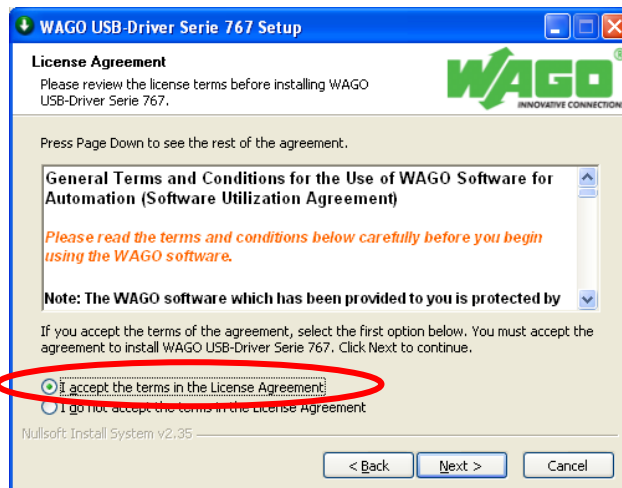

3. Read the Terms of Use for the WAGO USB driver before selecting "I accept...". Confirm this selection. Then click on [Continue].



4. Click [Next >].



5. Complete the installation of the WAGO USB driver by clicking the button [Finish].

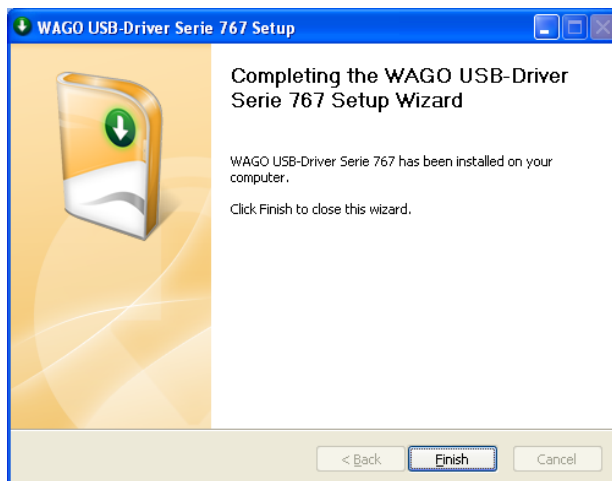

6. Confirm completion of installation of the WAGO-specific add-ons by clicking the button [Finish].

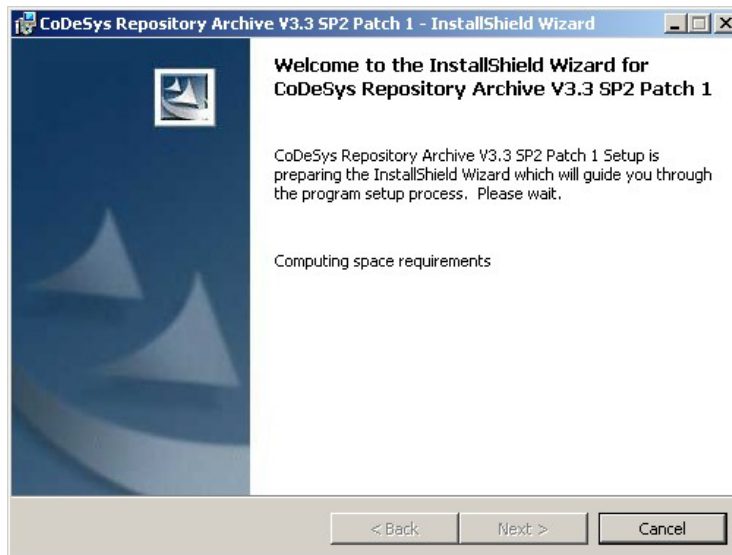

7. Click [Next >].

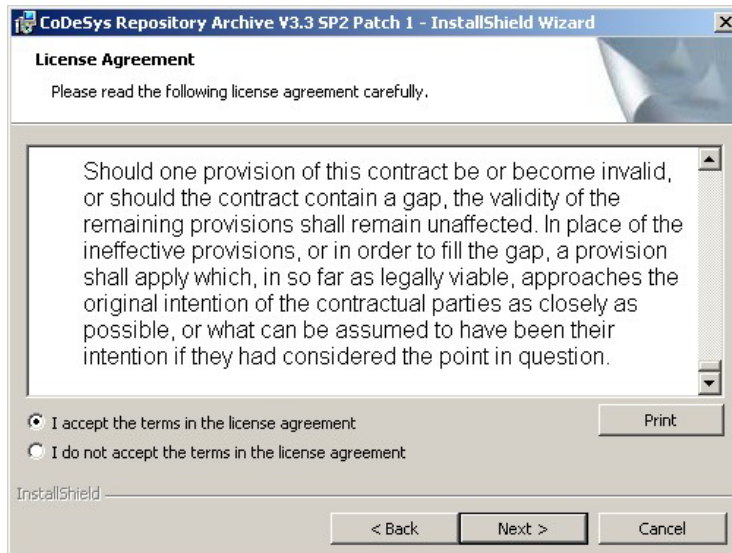

8. Read the Terms of Use for the "CoDeSys Repository Archive" to activate "I accept... ". Confirm this selection. Then click on [Next].

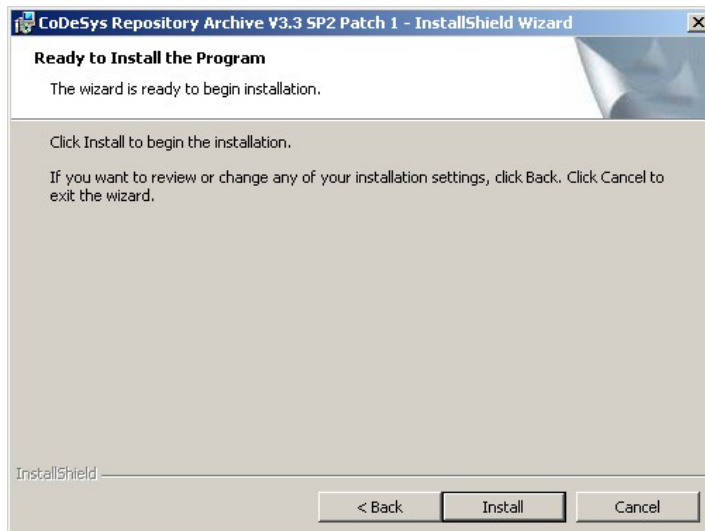

9. Start the installation by clicking [**Install >**].

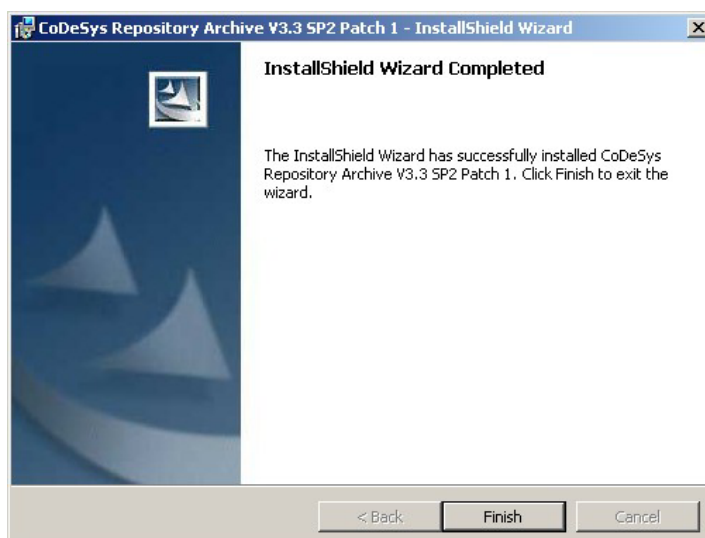
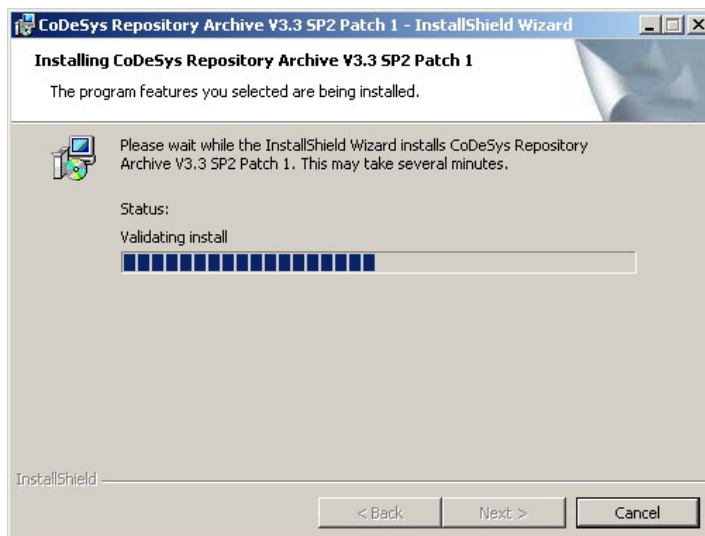

10. Complete the installation by clicking [**Finish >**].

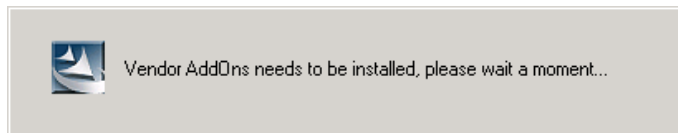

11. Installation of WAGO-specific add-ons may take up to 15 minutes, as CoDeSys 3 must be started several times in the background. There is no progress updating displayed during this time.

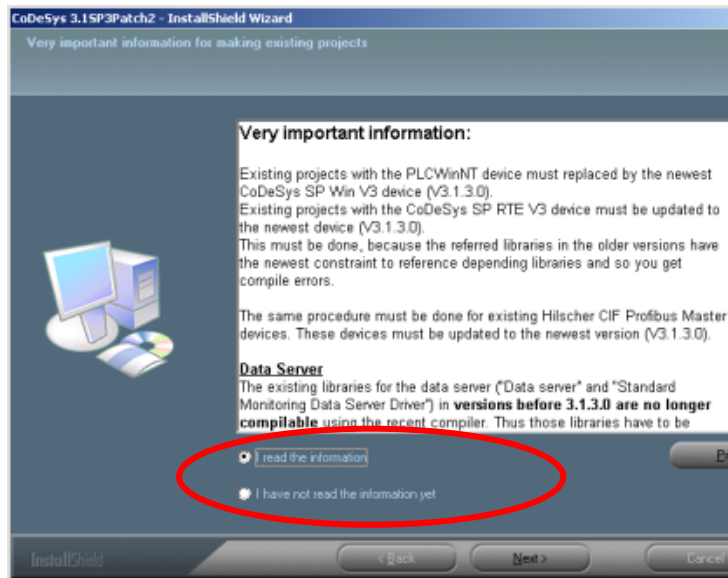

12. Confirm that you have read the information and continue with installation by clicking [Next >].

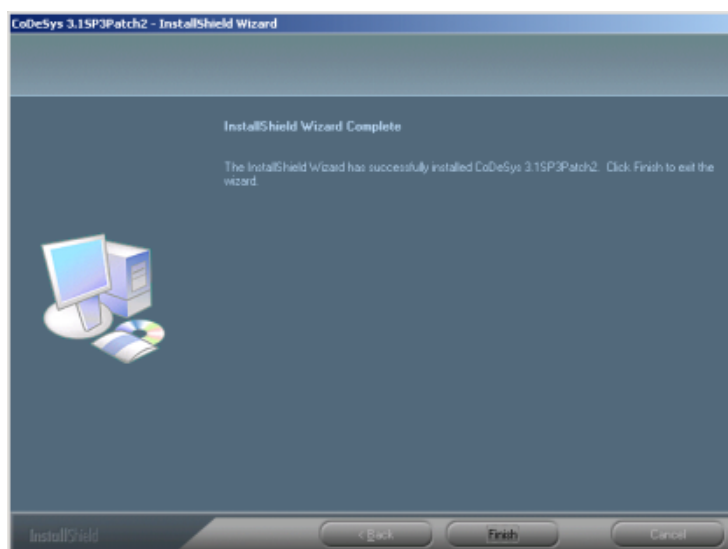

13. Finish the whole installation routine by clicking on [Finish >].

4.2 Editing the Gateway Configuration

Following a standard installation, the entry **ComPort=** in the file "Gateway.cfg" must be edited to reflect local conditions.

To do this, open the "Edit Gateway.cfg" link that was created on the desktop during CoDeSys installation.



Edit Gateway.cfg

If this link is not available on your desktop, the configuration file can typically be found under **Programs > 3S > CoDeSys > GatewayPLC**. Open the *Gateway.cfg* configuration file with an editor.

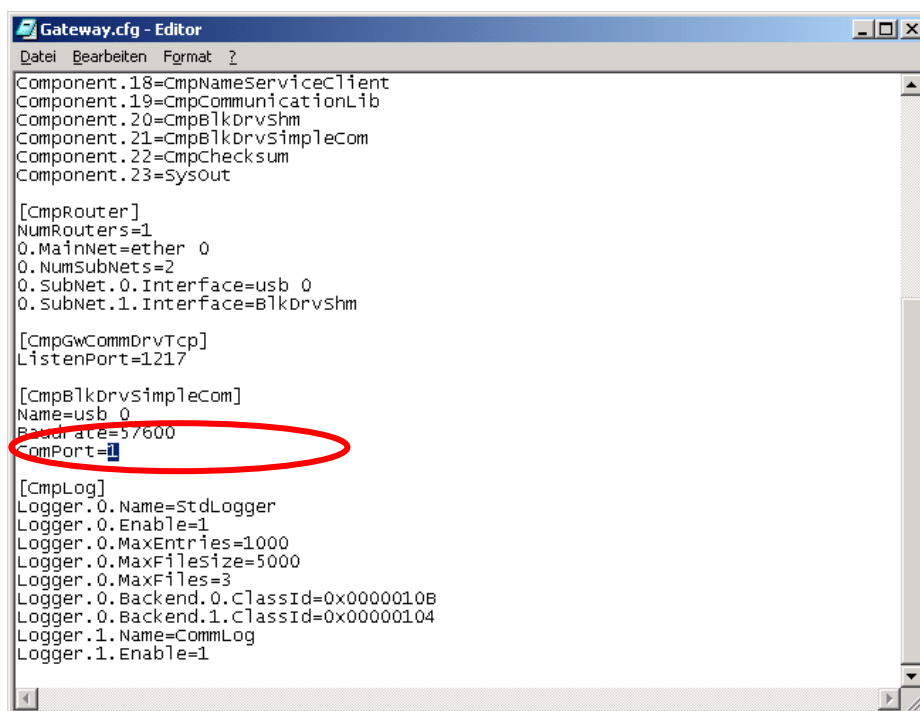

In the section **[CmpBlkDrvSimpleCom]** the entry **ComPort=** must be updated with the COM port number for the function "I/O-Programming".

```

[CmpBlkDrvSimpleCom]
Name=0
Baudrate=57600
ComPort=1
  
```

Replace the **1** with the new COM port number assigned for the "I/O-Programming" function during the installation of the USB communication driver.

Overwrite the modified configuration file as follows: Select **File > Save As...** In the **File Type** field, select "All files" to maintain the ".cfg" file ending. Click **[Save]** to overwrite.

4.2.1 Identifying Assigned COM Ports:

Double-click on the "Remove Hardware" icon in the taskbar to display the existing COM ports.



Assigned COM ports are not displayed unless the "Display device components" selection box has been selected.



Note



This COM port number remains constant only when the same USB slot is used for connection with the fieldbus coupler.

The same information can also be requested via Device Manager: **Start > Settings > System control panel > Administration > Computer administration > Device Manager -> Ports (COM and LPT)**.

Or, by default, under Windows XP via: **Start > System control panel > Printer and other hardware > on the left "System" > select "Hardware" rider > Device Manager > "+" before the "Ports (COM & LPT)" entry.**

4.3 Your Initial CoDeSys 3 Project

A minimal CoDeSys program is created for the fieldbus coupler loaded and debugged in this section.

Start CoDeSys using the shortcut on the desktop, or with:
START > Programs > 3S CoDeSys > CoDeSys > CoDeSys V3.3 SP2 Patch1 Hotfix2.

1. Select **File > New project...** in the menu.

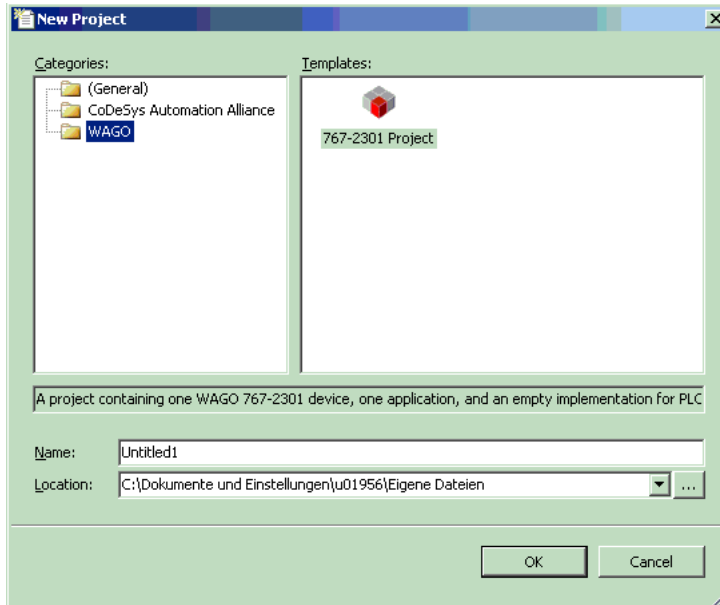

2. Mark the template "767-2301 Project" under the category "WAGO" and assign a name under which the project is to be saved.
3. Set the location to save the project and close the window by clicking **[OK]**.

A base project is created in the background which already contains the objects Device, OnBoard-8DI, Task system, Task, POU, etc.

You can achieve the same results if you begin with a blank project and then manually add the necessary objects.

If you do this, don't forget to set "Application" as "Active application" using the context menu.

Shown below is the base project generated from the template after switching to the tab "Devices" and after all the project tree elements have been expanded.

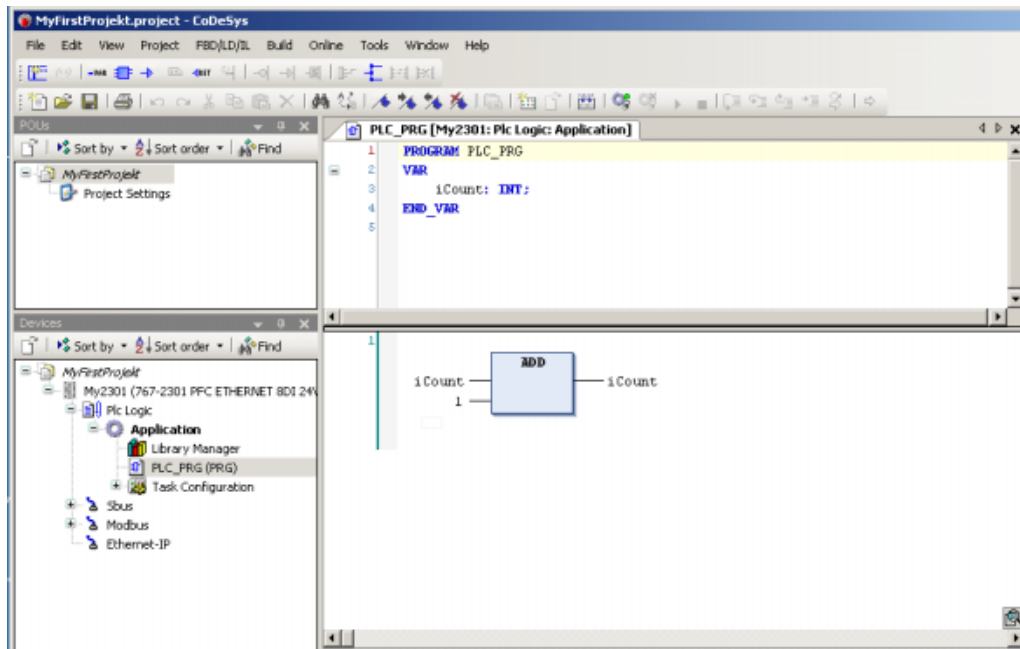

The new application is to output the count "iCount" to the 8 DOs of a 767-4801 module.

4.3.1 Adding IO Modules

1. Mark the entry "Sbus" in the device tree using the right mouse button and select **Add device...** from the context menu.
2. Mark the 8DO module 767-4801 and assign a name for it (e.g., "My8DO"). Load the module to your project using the button **[Add Device]**. Close the dialog window with the button **[Close]**.

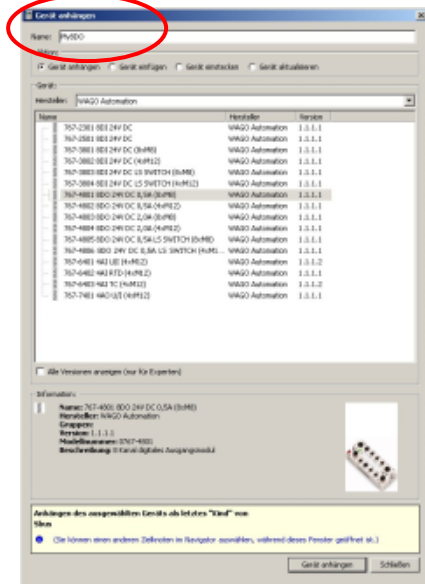

3. In the device tree double click the entry "My8DO" to open the S-BUS editor. Switch to the S-BUS editor using the tab "Sbus configuration". Assign a value of 1 to the parameter "Module slot index in Sbus". The "Module slot index in Sbus" parameter corresponds to the position of the 8DO module on the S-BUS. The next I/O module would then have the slot number 2.

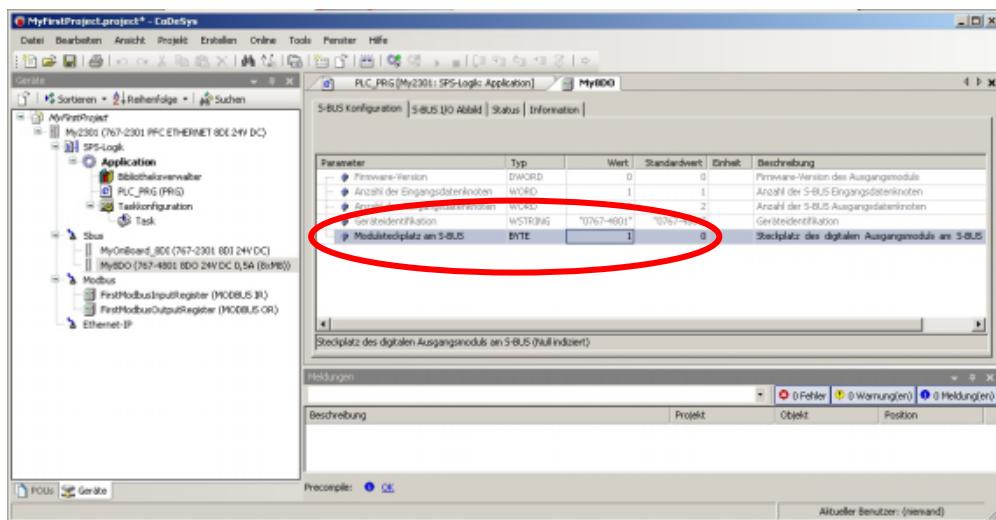

4.3.2 Creating Output Variables

1. Go to the tab "I/O image status" and generate a new global variable "bOut" by opening the insert mark on the second line and specifying a variable name (here "bOut").

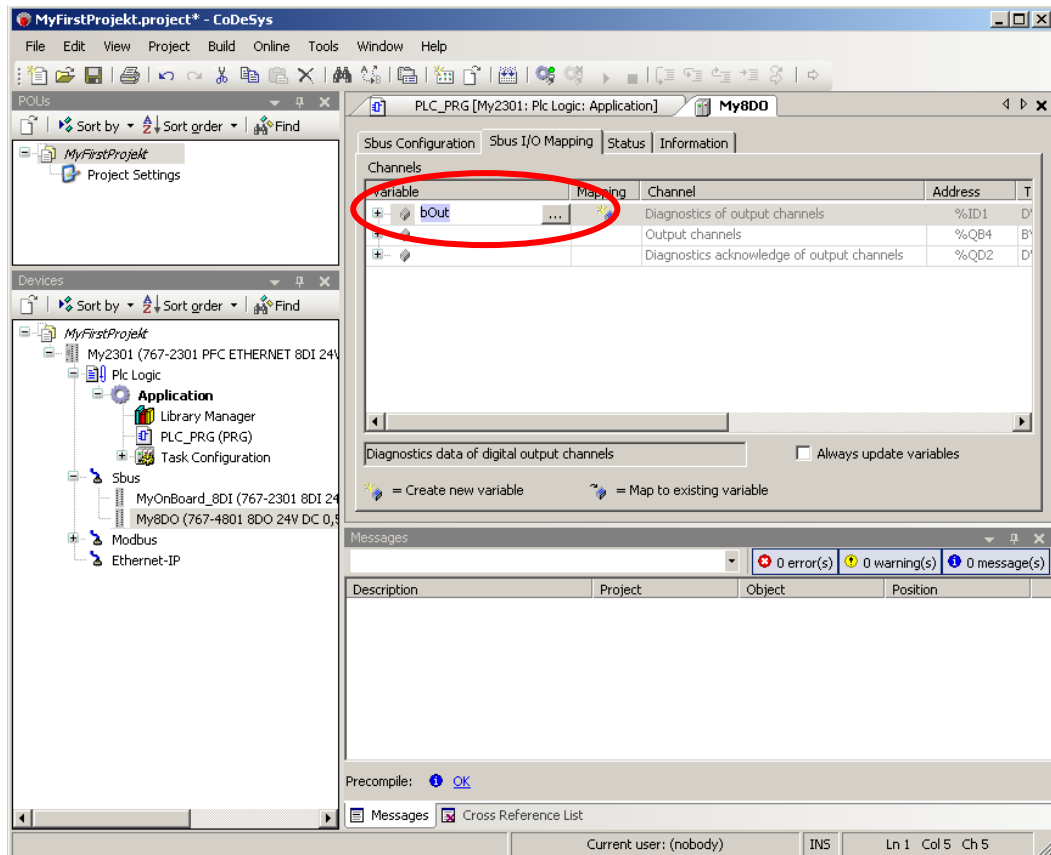

As an alternative you can also map the outputs to a variable already defined in a POU. The type of mapping is displayed in the second column by a symbol.



2. To configure mapping for an existing variable set the insert mark to the required hardware address and click the button [...], or press [F2]. The input assistant is then opened to allow you to access all declared variables.

4.3.3 Adding Instructions

1. Double click on "PLC_PRG" to switch to the code editor. Add a "new network" using the context menu.

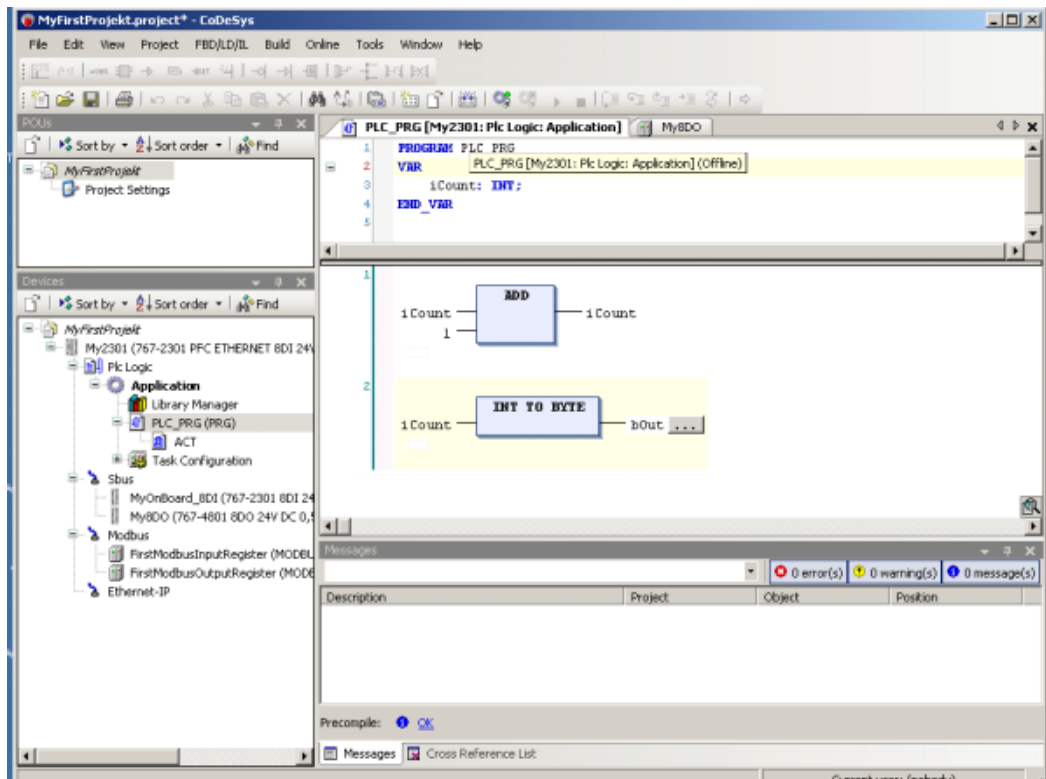

2. Add the conversion function using "Add module call".

In the example given here the count "iCount" is converted to the "BYTE" data type and then assigned to the previously generated variable "bOut".

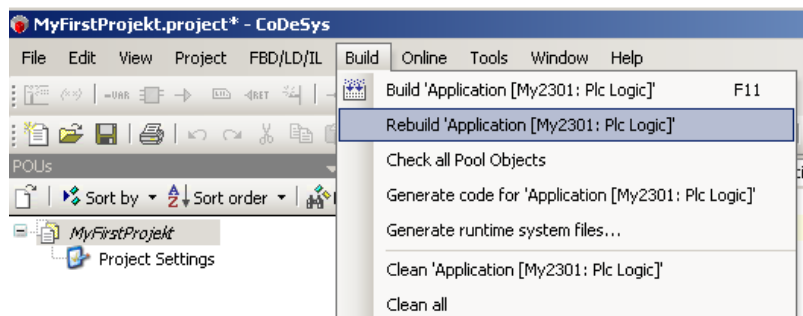

3. In the menu **Create** first select **Clear everything** and then **Retranslate application[<Project name>]** to generate the application.



4.3.4 Setting Communication Parameters

The communication settings must be edited in order to load the program to the control system.

1. Double click on "My2301 (767-2301 PFC ETHERNET 8DI 24V DC)" to open the communication parameter editor.

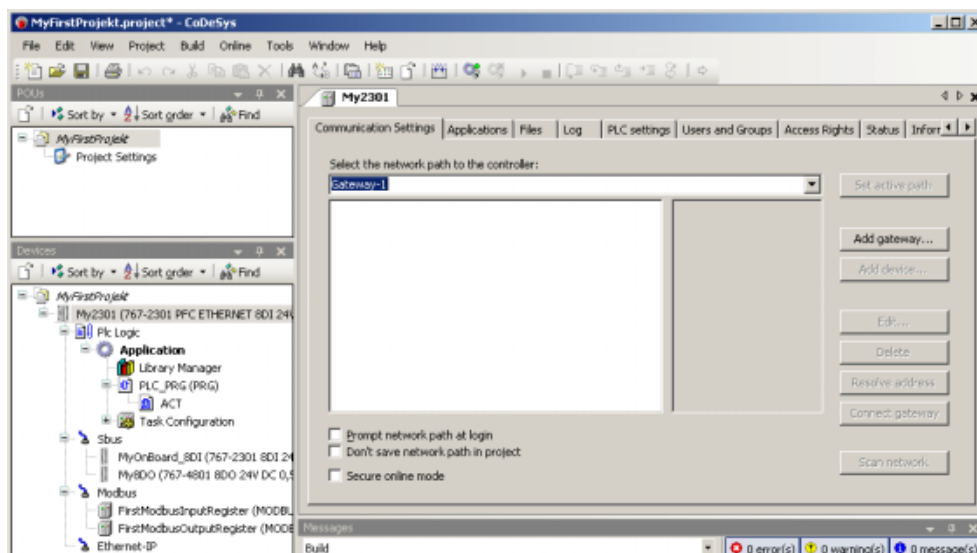

2. Use the button **[Add gateway ...]** to create a set of parameters to be used for managing the Speedway device.

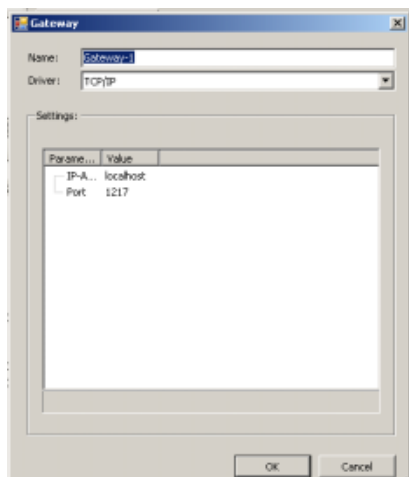

3. Give the set of parameters any name you would like. The remaining parameters can be loaded without any changes when you are using only one network card by clicking the button **[OK]**.
4. Click **[Scan network]** to obtain a list of all available CoDeSys 3 devices.

Note



The PC and the fieldbus coupler must be in the same subnet!



Note

The CoDeSys gateway on the PC will latch on to all available Ethernet ports when this function is started.

Restart the gateway function using the context menu of the CoDeSys icon in the task bar (see the following figure).

If your fieldbus coupler is not found, delete any gateway entries that may be present and perform steps 2 to 4 again.



5. If the fieldbus coupler is contained in the list, select it and load it to your project via [Set Active Path].

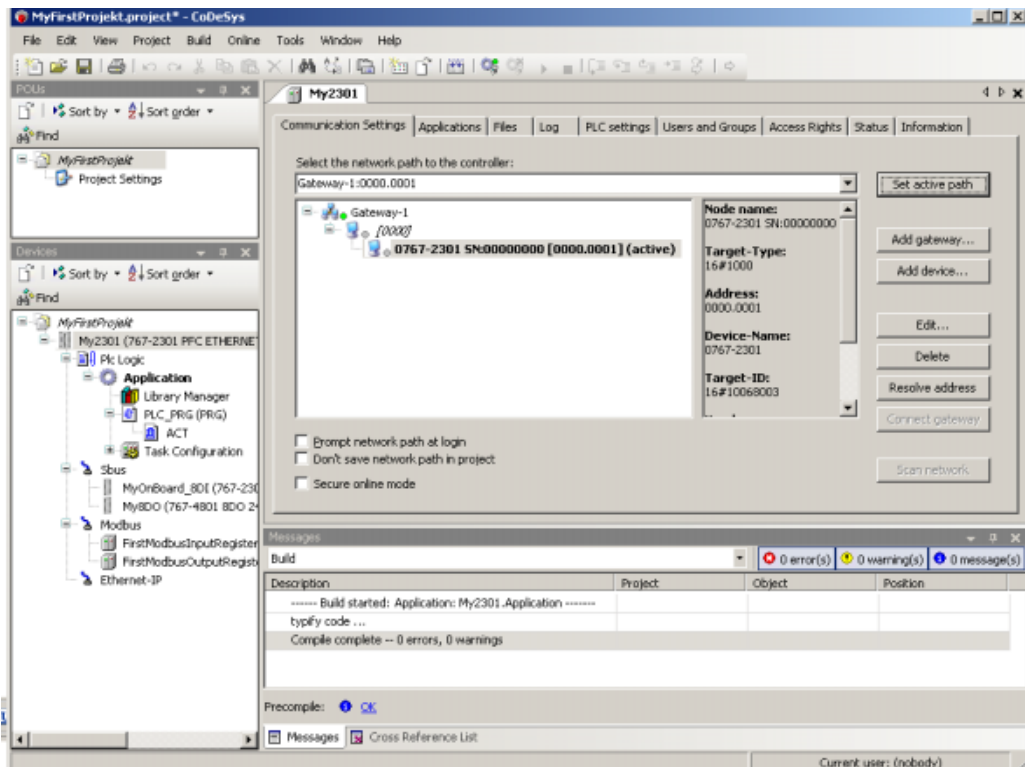

When the communication parameters have been configured successfully the entry for the 767-2301 is highlighted in bold.

4.3.5 Logging In and Starting the Application

1. To load the program to the control system, go to the menu **Online** and select **Log in ...**, or press the key combination **[Alt] + [F8]**.

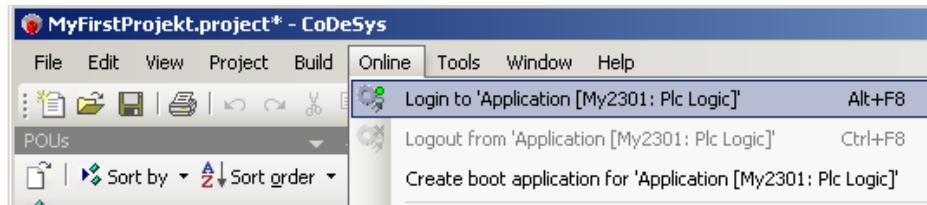

2. Start the program in the control system with **Online > Start**, or press **[F5]**.

The current variable values are shown while you are online.

4.3.6 Creating a Boot Project and Activating the Automatic Start

1. In the menu **Online**, select the item **Create boot application ...** to write the program permanently to the control system.

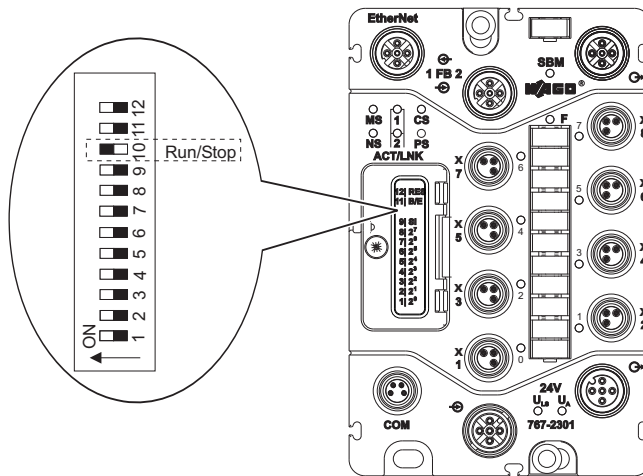

2. Set the switch 10 (Run/Stop) to "ON" (Run) to enable the PLC program to start up automatically after each restart.

5 Ethernet Port

5.1 IP Address Allocation

The fieldbus coupler can obtain its IP address dynamically (from a server) or it can be configured with a static (fixed) IP address.

Dynamic IP address allocation can be performed using the BootP or DHCP protocol. Dynamically assigned IP addresses are not saved however. Therefore, a BootP or DHCP server must be available each time the fieldbus coupler is switched on.

Configuration of a static (set) IP address may be conducted:

- using the DIP switch on the fieldbus coupler,
- via web-based management or
- using the "WAGOframe" configuration software

In the default status, the assignment of dynamic IP addresses is activated via the BootP protocol.

To access the web-based management in a browser, the fieldbus coupler requires a known IP address. This initial IP address can be assigned via BootP, DIP switch or using the WAGOframe configuration software.

With the default status as the basis, allocation of an IP address via DIP switches and BootP is presented below. For a complete list of IP address allocations, refer to the manual for the 767-2301.

5.1.1 Allocation of a Set IP Address using DIP Switches

In the default status, the top 3 bytes (network ID) are assigned "192.168.1." and the subnet mask 255.255.255.0.

Use the DIP switch block (switch 1 ... 8) to set the last byte (Host ID) of the IP address. Use switches 1 – 8 to set the last byte (host ID) of the IP address. To do this, switch 9 (Set Network) must be set to "On".

Switches	1	2	3	4	5	6	7	8	9	10	11	12
Binary values for setting addresses/functions	2^0 (1)	2^1 (2)	2^2 (4)	2^3 (8)	2^4 (16)	2^5 (32)	2^6 (64)	2^7 (128)	Set Network	Run/Stop	Boot/Execute	Reset
Switch setting	Off	Off	Off	Off	Off	Off	Off	Off	Off	Off	Off	Off

Proceed as follows to set the IP address 192.168.1.100, for example:

1. Open the cover by unscrewing the M4 screw with a screwdriver.
2. Move switch 9 (Set Network) to "On" to activate IP address allocation using DIP switches.
3. For Host ID 100 set switches 3, 6, 7 to "On".
($2^2+2^5+2^6 = 4+32+64 = 100$).
4. Close the cover and screw it securely in place to maintain degree of protection IP 67.

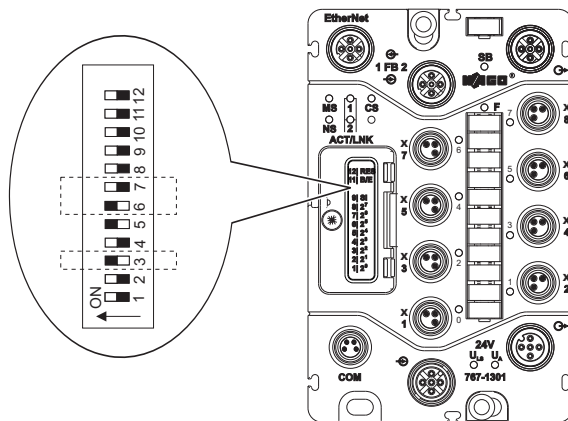

With the 8 available switches you can set addresses from 1 – 254. Addresses 0 and 255 are reserved and shall not be used.

5.1.2 Allocation of a Dynamic IP Address using BootP

In the default status, IP address allocation is activated via the BootP protocol. Allocation of the IP address using BOOTP is illustrated here with the example of the WAGO BootP server.

Configuring the BootP server

To communicate with the fieldbus coupler in a local network you must first determine the MAC address for the fieldbus coupler and then assign an IP address to it.

1. Take note of the hardware address (MAC address) of the fieldbus coupler. This can be found on the label on the side of the fieldbus coupler.

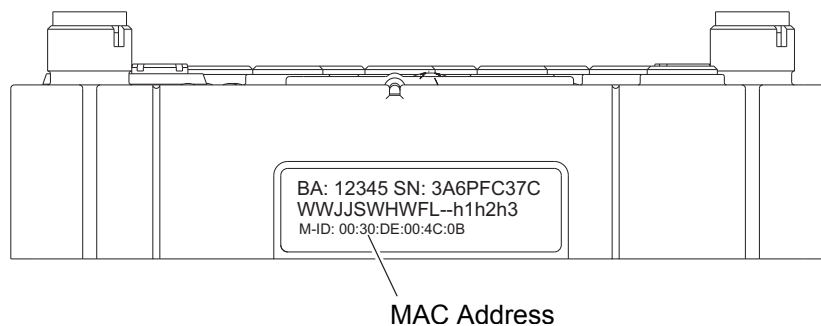

Fig. 1: Example of a MAC address on the adhesive label on the left side of the fieldbus coupler

2. Click the **[Start]** button and start the WAGO BootP server under **Programs > WAGO Software > WAGO BootP Server**.
3. Open the configuration file in which you are assigning the MAC address to an IP address from the local network. To do this, click **[Edit BootPtab]** in the BootP server. The configuration file will then be opened.
4. Click in the line that begins with "node", for example
`"my2301:ht=1:ha=0030DE00001C:ip=192.168.1.100:sm=255.255.255.0:"`.
5. Replace the 12-character MAC address after
`":ha="` with the address printed on the label (13).

6. Enter an IP address after "ip=". In the example shown here, this is 192.168.1.100. Separate the individual numbers with a decimal point.
7. To address more than one fieldbus node, add a line for each node with the corresponding assignment for each additional fieldbus coupler to the file bootptab.txt. Repeat steps 5 to 7 for this.
8. Save your new settings in the file "bootptab.txt". To do this, click on "File" in the menu and select "Save".
9. Close the editor.

Assigning an IP address using the WAGO BootP server

1. To start the BootP server click the button **[Start]** in the BootP dialog window that is opened. Various messages will be displayed in the window. The error messages indicate that some services (e.g., port 67, port 68) in the operating system have not been defined. You can ignore these error messages.

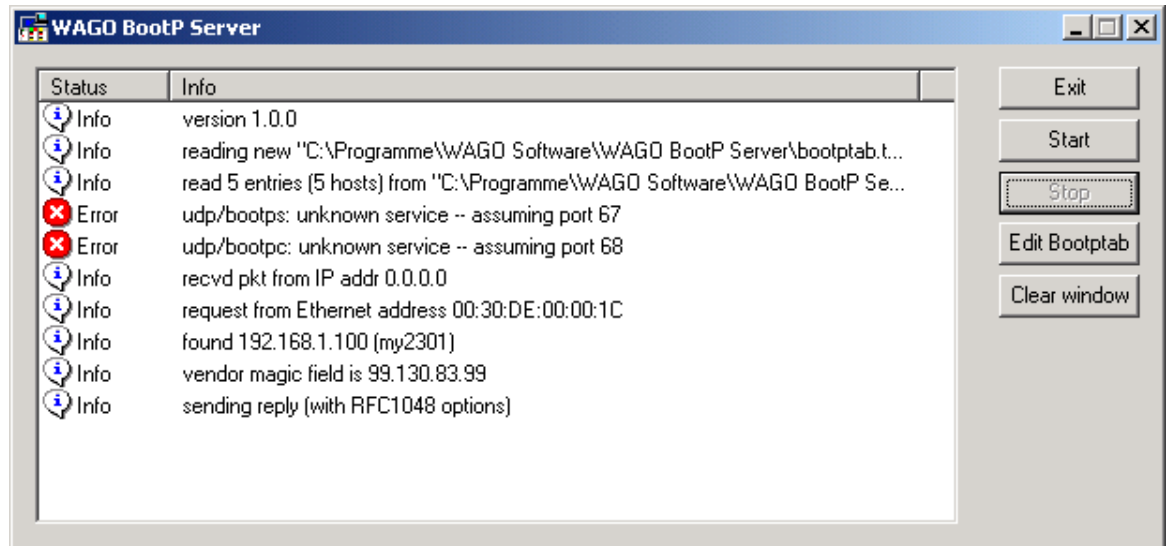

Fig 3-10: Dialog window of the WAGO BootP server with messages

2. Restart the fieldbus coupler by moving the "Reset" DIP switch to ON and then back to OFF. Or turn off the fieldbus coupler voltage for two seconds and turn it on again.
A request appears from the fieldbus coupler. The BootP server replies that the IP address has been accepted (no errors). The IP address is now temporarily available in the fieldbus coupler, but is not yet permanently saved. On a restart, the fieldbus coupler will therefore expect to receive an IP address from the BootP server.
3. Click **[Stop]**, then **[Exit]** to close the BootP Server.
4. To permanently save the IP address in the fieldbus coupler, select the option "Static IP" in the "TCP/IP" view of the web-based management. Or use WAGOframe by selecting "Device memory" under the "IP address obtained from" parameter.

5.1.3 Testing the Network Connection

Carry out a ping network function to check whether the fieldbus coupler can be reached at the IP address you have assigned in the network. To do this, open the DOS window by clicking on **[Start]** and selecting **Programs > Run**. Enter `cmd` in the dialog box and click **[OK]**.

In the DOS window, enter the command `ping` and the IP address of the fieldbus coupler; e.g.: `ping 192.168.1.100`.

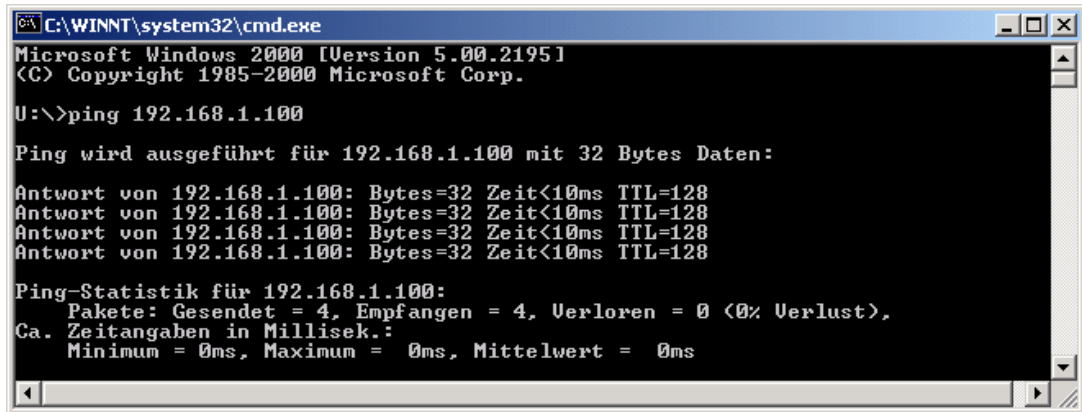

```

C:\WINNT\system32\cmd.exe
Microsoft Windows 2000 [Version 5.00.2195]
(C) Copyright 1985-2000 Microsoft Corp.

U:\>ping 192.168.1.100

Ping wird ausgeführt für 192.168.1.100 mit 32 Bytes Daten:

Antwort von 192.168.1.100: Bytes=32 Zeit<10ms TTL=128
Antwort von 192.168.1.100: Bytes=32 Zeit<10ms TTL=128
Antwort von 192.168.1.100: Bytes=32 Zeit<10ms TTL=128
Antwort von 192.168.1.100: Bytes=32 Zeit<10ms TTL=128

Ping-Statistik für 192.168.1.100:
    Pakete: Gesendet = 4, Empfangen = 4, Verloren = 0 (0% Verlust),
    Ca. Zeitangaben in Millisek.:
        Minimum = 0ms, Maximum = 0ms, Mittelwert = 0ms
  
```

Your PC sends out an inquiry that is answered by the fieldbus coupler. This reply appears in the DOS window. If the error message "Timeout" appears, the fieldbus coupler has not responded properly. You then need to check your network settings.

5.2 User Administration

Access to the web-based management and via FTP is password protected. In the default status, the following users and access authorizations are defined:

User name	Password	WBM	FTP	WAGOframe
admin	wago	Full access	Full access	Full access
user	user	Limited access	Full access	Limited access
guest	guest	Limited access	Full access	Read access

Use WBM and WAGOframe to change the passwords.

5.3 File System

Three partitions of the file system are available to the user including a RAM disk and two partitions in Flash memory.

Partition	Format	Type	Size	Use
R:\	FAT 12	RAM disk	1MB	-
U:\	FAT 12	Flash disk	1MB	WBM pages
P:\			1MB	CoDeSys programm

The R:\ partition is designed as nonpermanent RAM disk and can be used to temporarily store data. These files are lost when the system is restarted. To save files permanently, use partitions "U:\ and P:\.

The WBM sites are located in "U:\". Partition "P:\ " can be accessed by FTP and also directly from the CoDeSys development environment.

5.3.1 Access via FTP

Partition U:\ is the start directory for incoming FTP connections.

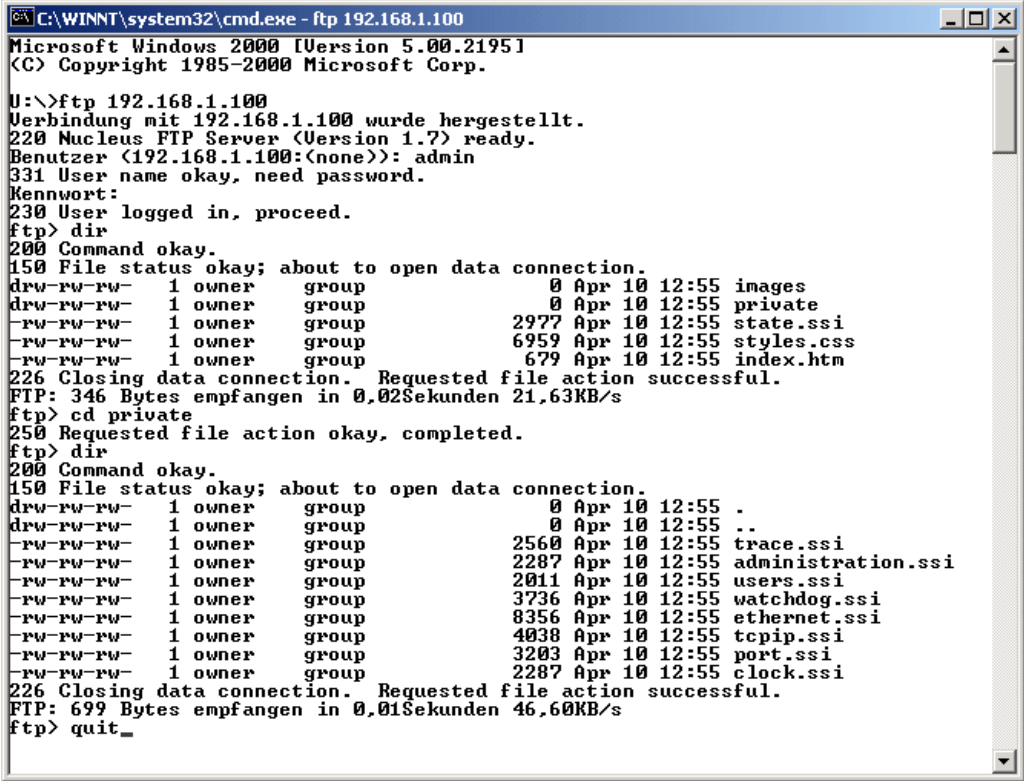

```

C:\WINNT\system32\cmd.exe - ftp 192.168.1.100
Microsoft Windows 2000 [Version 5.00.2195]
(C) Copyright 1985-2000 Microsoft Corp.

U:\>ftp 192.168.1.100
Verbindung mit 192.168.1.100 wurde hergestellt.
220 Nucleus FTP Server (Version 1.7) ready.
Benutzer (192.168.1.100:(none)): admin
331 User name okay, need password.
Kennwort:
230 User logged in, proceed.
ftp> dir
200 Command okay.
150 File status okay; about to open data connection.
drw-rw-rw-  1 owner  group           0 Apr 10 12:55 images
drw-rw-rw-  1 owner  group           0 Apr 10 12:55 private
-rw-rw-rw-  1 owner  group       2977 Apr 10 12:55 state.ssi
-rw-rw-rw-  1 owner  group       6959 Apr 10 12:55 styles.css
-rw-rw-rw-  1 owner  group        679 Apr 10 12:55 index.htm
226 Closing data connection. Requested file action successful.
FTP: 346 Bytes empfangen in 0,02Sekunden 21,63KB/s
ftp> cd private
250 Requested file action okay, completed.
ftp> dir
200 Command okay.
150 File status okay; about to open data connection.
drw-rw-rw-  1 owner  group           0 Apr 10 12:55 .
drw-rw-rw-  1 owner  group           0 Apr 10 12:55 ..
-rw-rw-rw-  1 owner  group       2560 Apr 10 12:55 trace.ssi
-rw-rw-rw-  1 owner  group       2287 Apr 10 12:55 administration.ssi
-rw-rw-rw-  1 owner  group       2011 Apr 10 12:55 users.ssi
-rw-rw-rw-  1 owner  group       3736 Apr 10 12:55 watchdog.ssi
-rw-rw-rw-  1 owner  group       8356 Apr 10 12:55 ethernet.ssi
-rw-rw-rw-  1 owner  group       4038 Apr 10 12:55 tcpip.ssi
-rw-rw-rw-  1 owner  group       3203 Apr 10 12:55 port.ssi
-rw-rw-rw-  1 owner  group       2287 Apr 10 12:55 clock.ssi
226 Closing data connection. Requested file action successful.
FTP: 699 Bytes empfangen in 0,01Sekunden 46,60KB/s
ftp> quit_

```

The example here illustrates the contents of the folder "U:\private\ ". These files represent the source code for the web-based management.

5.4 Web-Based Management (WBM)

Nearly all settings can be viewed and edited via Web-Based Management. To use this, start your browser and enter "http://" into the address line, followed by the IP address of the 767 node (for example: http://192.168.1.100).

Navigation

- Information
- TCP/IP
- Port
- Watchdog
- Clock
- Ethernet
- Users
- Administration

Status Information

Coupler Details

Order Number	0767-2301
Mac Address	00:30:DE:00:12:34
Firmware Revision	01.01.08 (01)

Network Details

IP address	192.168.1.100
Subnet mask	255.255.0.0
Gateway	0.0.0.0
Hostname	0030DE001234
Domainname	wago.com

Module Status

State Modbus Watchdog TCP:	Disabled
State Modbus Watchdog UDP:	Disabled
Error Group	0
Error Code	0
Error Argument	0
Error Description	Coupler running, OK

All of the WBM linked pages are password protected.

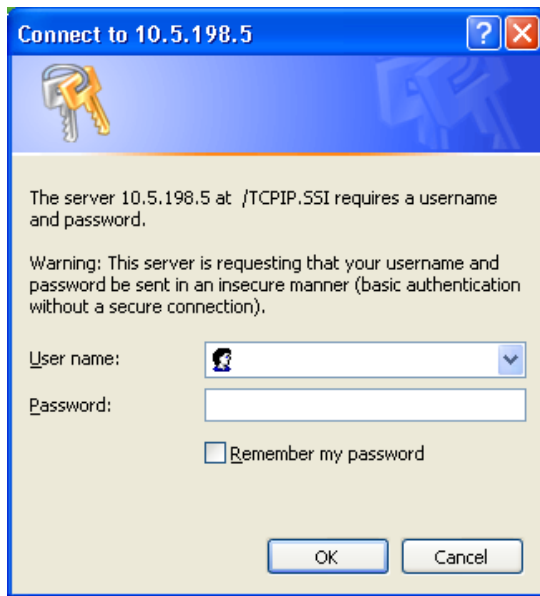

User	Password
admin	wago
user	user
guest	guest

Further information is given on the specific WBM page or in the 767-2301 manual.

6 WAGOframe

WAGOframe is an FDT/DTM frame application for configuration, diagnosis and updating of FDT-compliant field devices.

FDT/DTM is a manufacturer-independent concept for setting of parameters for field devices from different manufacturers using only a single program. The phrase "Field Device Tool"(FDT) not only represents a concrete program, but also defines the interfaces that a program must deal with in order to cooperate with DTMs from different manufacturers.

A "Device Type Manager"(DTM) groups all the setting options for a field device (including graphic interfaces) into a single program that is executed in an FDT/DTM frame application. The specification makes a distinction between device DTMs, communication DTMs and gateway DTMs.

6.1 Installation

A browser-based wizard leads you through the installation of the required drivers, DTMs and programs. When performing an installation from the CD, the Internet browser used will open automatically to the following page:

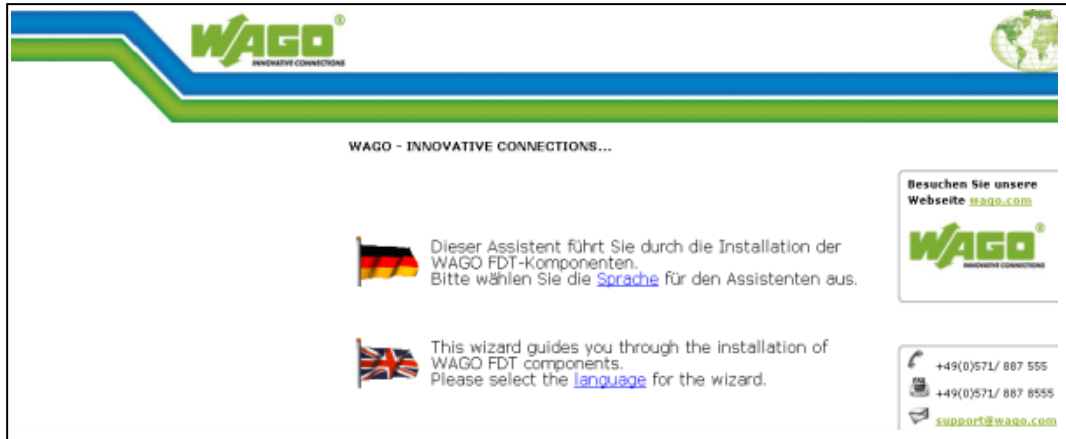

1. When performing an installation from the file system switch to the directory "`~/WAGOframe CD-ROM_v3.0.0`" and open the file "`Deutsch_main.htm`".



2. To install all the required components, select "Series 767 + WAGOframe".

- The following page will be displayed. Execute all five installation programs one after the other to install the configuration software.



The screenshot shows the WAGO website's installation page. At the top left is the WAGO logo with the tagline 'INNOVATIVE CONNECTIONS'. At the top right is a globe icon. Below the header, the text reads 'WAGO - INNOVATIVE CONNECTIONS...' followed by 'For the installation of the configuration software you accomplish please successively all five specified setup routines:'. To the right of this text is a box with the website URL 'wago.com' and the WAGO logo. Below the text are five installation steps, each with an icon and a link: 1. 'Install USB driver for devices serie 767...' with a USB cable icon and link '759-922 (Version 1.2.3)'; 2. 'Install WAGOFrame...' with a software window icon and link '759-370 (Version 1.0.5)'; 3. 'Install WAGO-Service-Interface DTM...' with a circuit board icon and link '759-371 (Version 1.2.0)'; 4. 'Install DTM Serie 767...' with a terminal block icon and link '759-361 (Version 1.3.0)'. To the right of these steps is another box with contact information: '+49(0)571/ 887 555', '+49(0)571/ 887 8555', and 'support@wago.com'.

Note



Installation of the USB driver 759-922 is not required if this driver has already been installed via "CoDeSys 3" setup. Any USB driver that is already installed will then be updated.

If an older version of "WAGOframe" is installed, this must first be de-installed with the installation routine. The same applies to DTMs.

The installation sequence for the individual components is always the same, beginning with language selection.



1. Continue by clicking [OK].

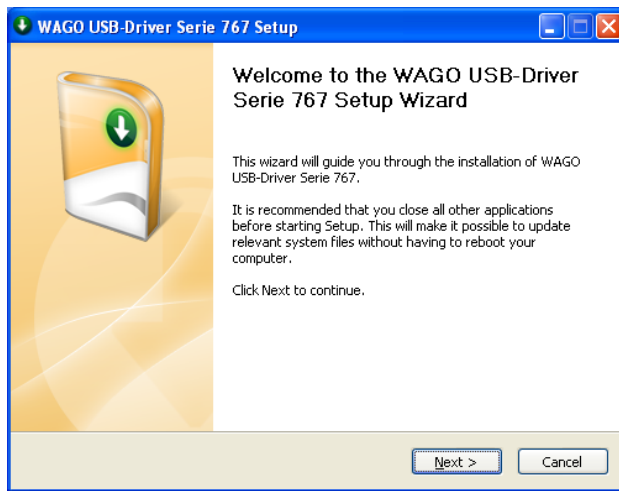

2. Continue by clicking [Next >].

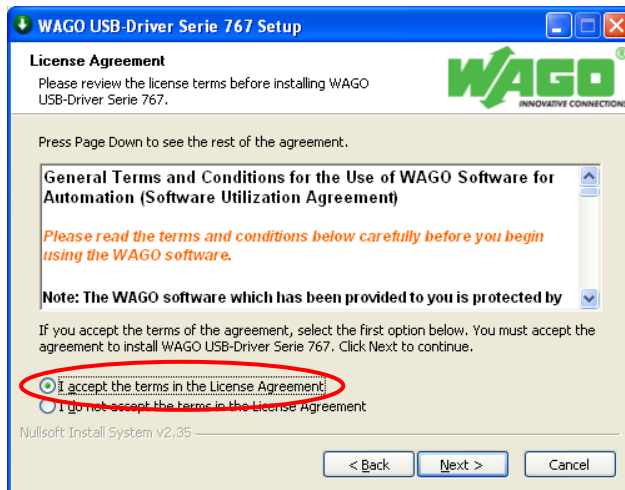

3. Read the Terms of Use for the WAGO USB driver before selecting "I accept...". Confirm this selection. Then click on [Next].

4. Check your personal settings.

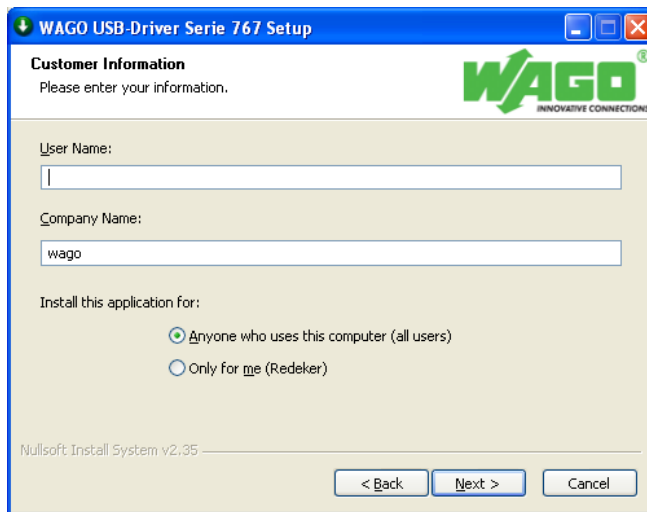

5. Continue by clicking [Next >].

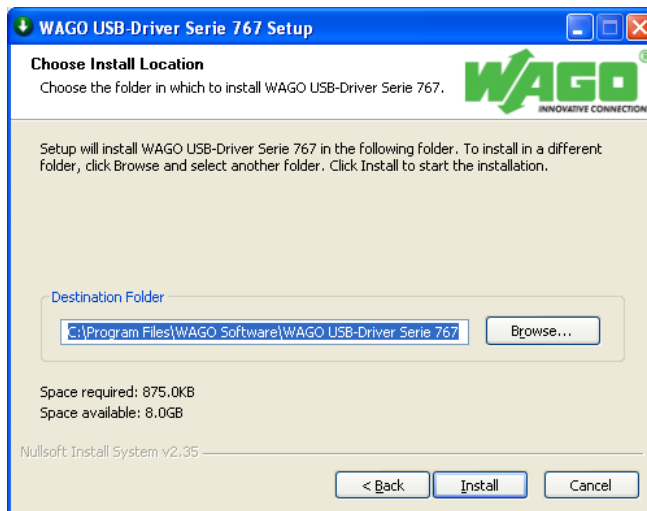

6. Select the installation path under which the application is to be saved.
7. Start the installation by clicking the [Install] button.

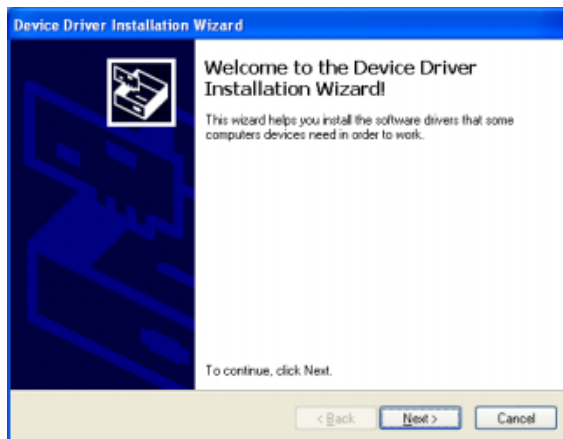

8. Continue by clicking [Next >].

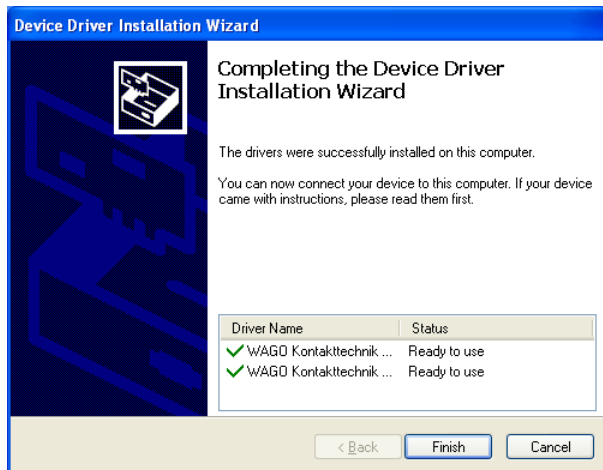

9. Complete the installation by clicking **[Finish]**.



10. Quit the wizard by clicking the **[Finish]** button.

Repeat these steps for the other four software components:

- WAGOframe: Item No. 759-370 (Version 3.0.0)
- WAGO service interface DTM: Item No. 759-371 (Version 2.1.0)
- DTM for the fieldbus coupler and I/O modules: Item No. 759-361 (Version 2.1.0)
- DTM for the system update: Item No. 759-362 (Version 1.0.0)

6.2 Starting Up the Fieldbus Coupler

Now switch on the power for the fieldbus coupler and link its service port to a free USB slot on your PC using the USB communication cable 756-4101/0042-0030.

Communication between WAGOframe and the fieldbus coupler is carried out via the communication DTM "WAGO Service Interface". The COM port that is used depends on the USB slot and must be parameterized accordingly in the WAGO Service Interface.

Note



If the fieldbus coupler is linked to a different USB slot at a later time, this will also result in a change to the COM ports used by "I/O-Service". In this case the setting for the serial interface must be adapted accordingly in the communication DTM.

6.3 Operation

Start the WAGOframe program using the icon on the desktop, or via **Start > Programs > WAGO Software > WAGOframe > WAGOframe**.



After starting you can select either the "Point to point mode" or the "Expert mode". The "Point to point mode" was developed specially for the configuration of simple devices (such as WAGO Jumpflex). Use the "Expert mode" to set parameters for the 767 components.

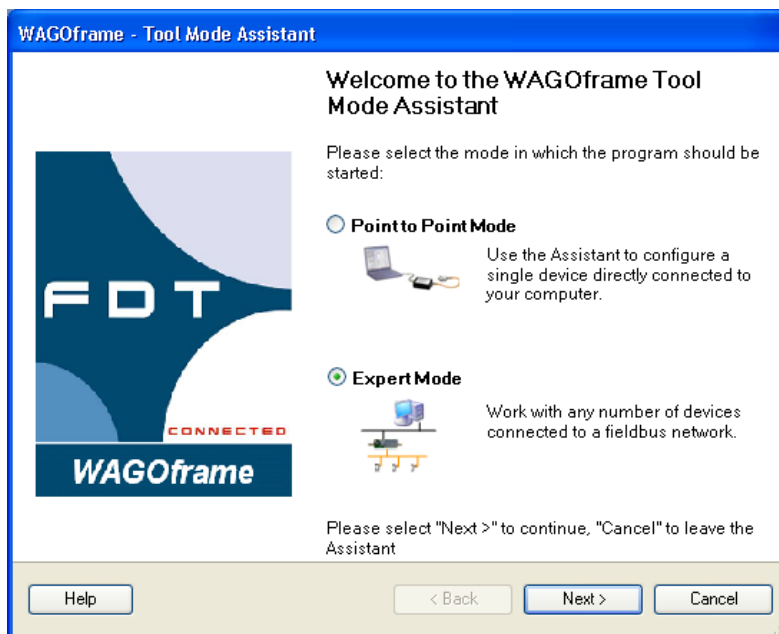

1. Switch to the "Expert mode" and click [Next >].

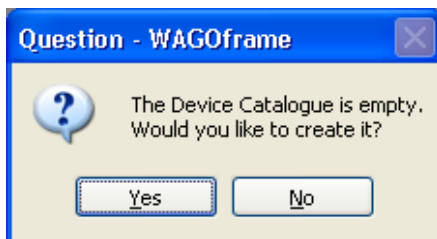

No device catalog will have been created on the initial call-up.

2. Click [Yes] in the dialog window that then appears to configure a device catalog on your PC.

3. In the window "Network view" mark the element "Network" and select the function **Add...** using the context menu (right mouse key). A dialog window then opens showing all available communication drivers.

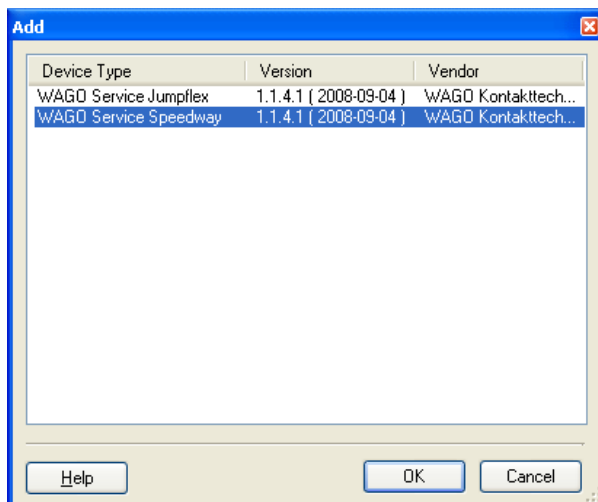
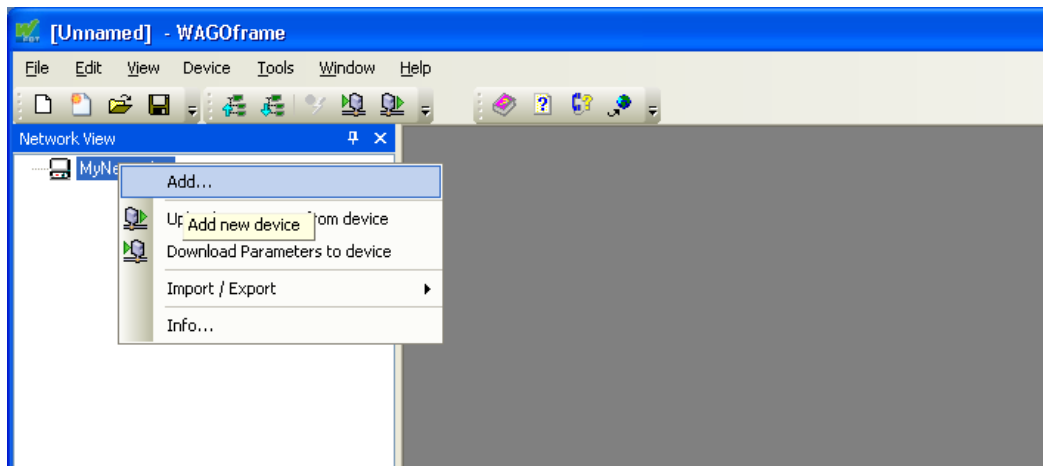

4. Select the "WAGO Service Speedway" communication driver and confirm your selection by clicking **[OK]**.
5. In the window "Network view" double-click on the newly added element "<->WAGO Service Speedway".

Setting the serial interface parameters for the "WAGO Service Interface" communication DTM.

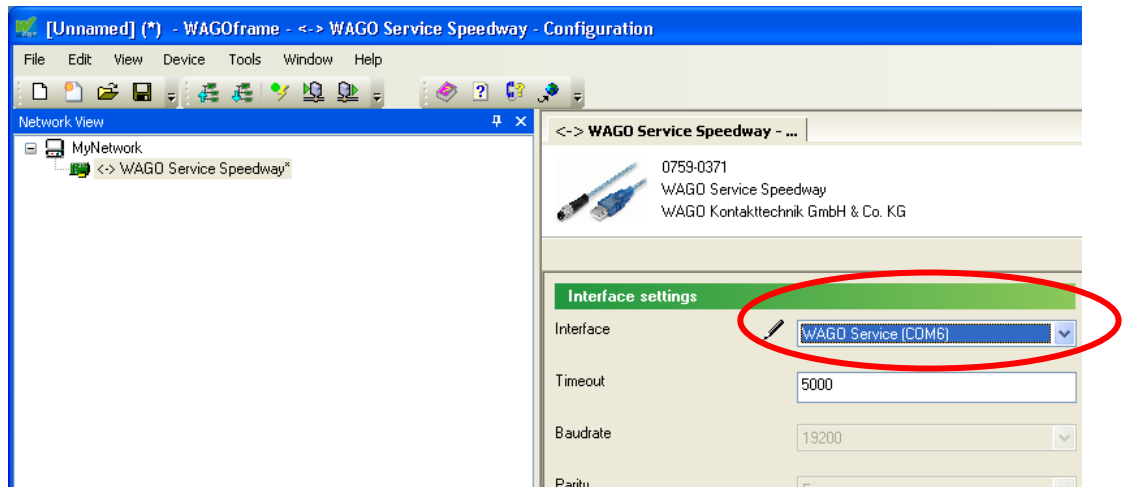

1. Select the interface to be used from the list and accept these settings.
If there are no entries in the list of available interfaces, check to ensure that the fieldbus coupler is switched on and that it is connected to your PC by the USB communication cable.
2. To complete the network configuration you can now select individual DTMs from the catalog, or conduct a network scan.

When adding elements manually please note that each FDT frame application differentiates between online and offline modes. Each of these modes has a separate scope of functions.

In the online mode, there is a direct link between the display and the connected 767 components.

The offline mode enables the parameterization of a device that is not yet present. It will continue to be used to reduce data transfer between WAGOframe and the device. If a device is in the online mode, its name is displayed in ***bold and cursive*** font in the network window.

- To conduct a network scan, open the context menu (right mouse key) of the element "WAGO Service Speedway" in the "Network" window and then select the entry **Create network** under the menu item **Scan**.

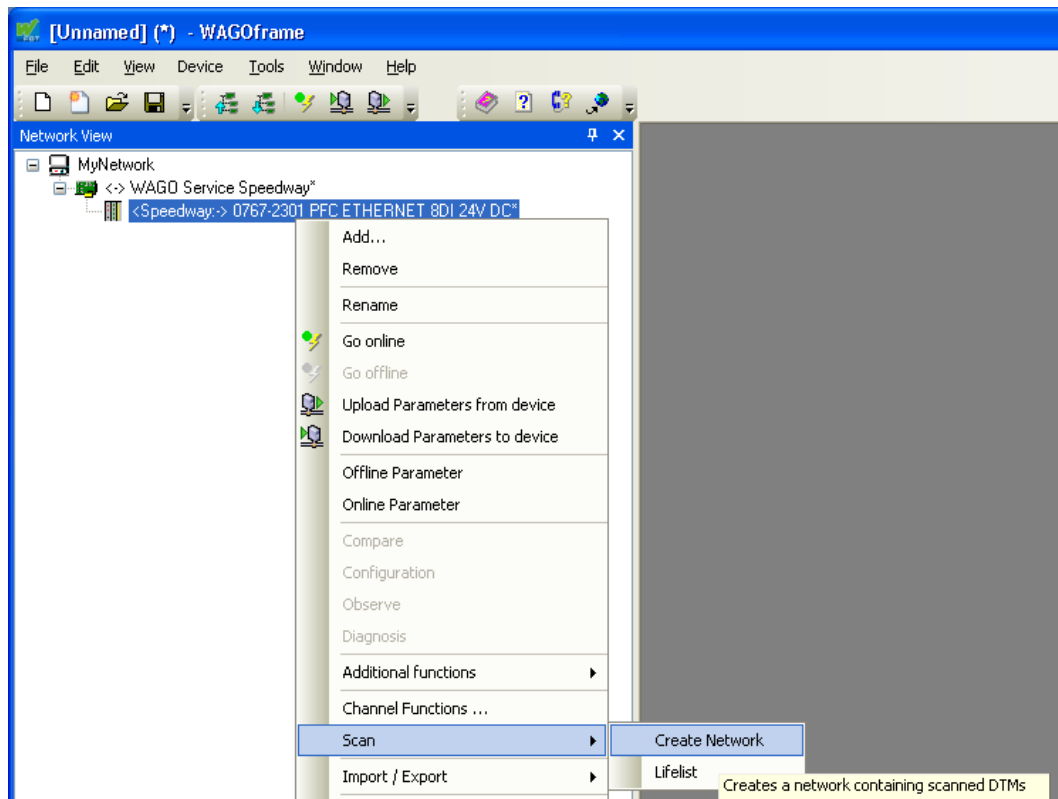

- After conducting a network scan, WAGOframe should have found the fieldbus coupler and the 8DO module 767-4801.
- A "Live List" is created if no matching DTM is found for the fieldbus coupler when scanning the network. Click on **[Add all and continue]** in the list.

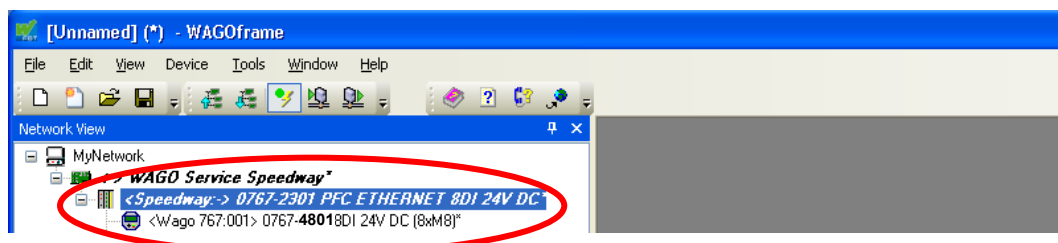

- Note that the fieldbus coupler is in the online mode, while the 8DO module is in the offline mode. Mark the 8DO module and select the entry **[Go online]** from the context menu to switch to the online mode.

7. Open the detail view by double-clicking the fieldbus coupler. WAGOframe should appear as follows after editing the window width and closing the device catalog:

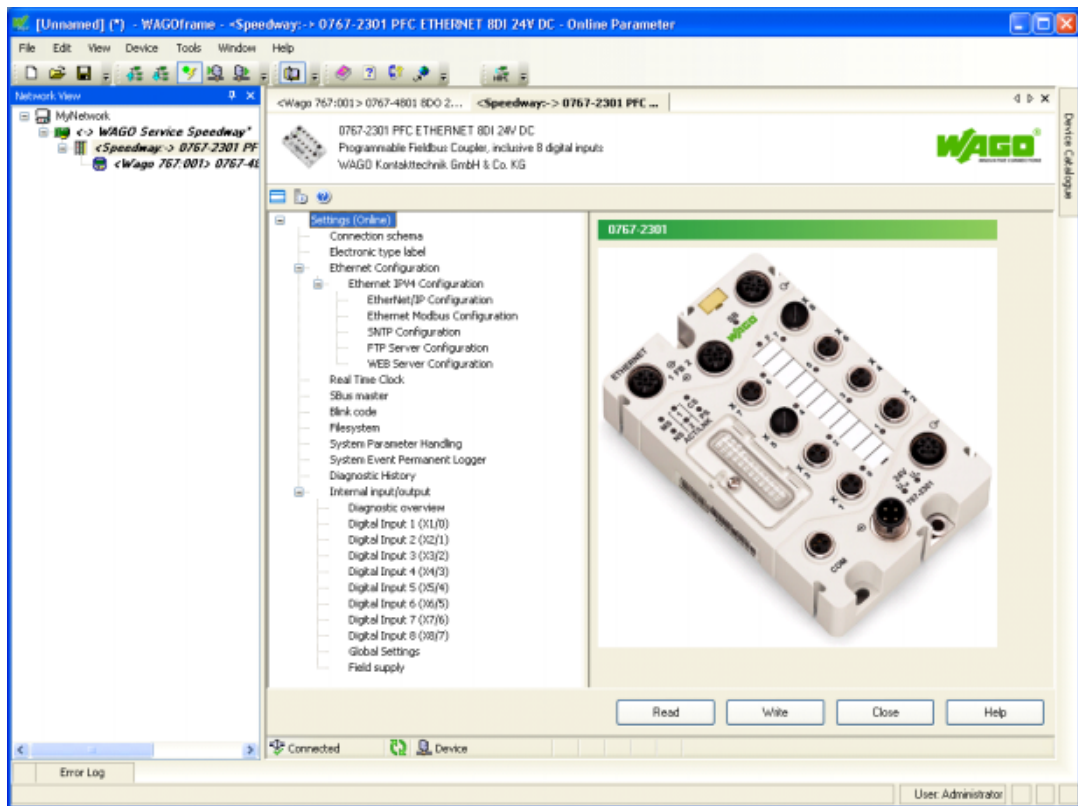

The current operating mode is shown in brackets behind the first node of the tree structure (left window). Please note that changing between operating modes is only possible when the detail window concerned is closed.

Explanations of the buttons:

- Read:
Reads and displays the parameters found in the fieldbus coupler.
- Write:
Writes the modified values to the fieldbus coupler.
- Close:
Closes the parameterization user interface (DTM).
- Help:
Opens the online help for an entry selected previously (e.g., digital input, blink code).

7 System Update

Firmware update for the 767 Series components is performed via system update. To ensure that the fieldbus node remains consistent and executable after updating the firmware, system update must be performed for both fieldbus coupler and connected I/O modules.

NOTICE

System update via fieldbus couplers

Before updating, observe the following measures to prevent any possible damage to the 767 system:

- The power supply must not be disconnected while updating!
 - To exclude any interferences by the fieldbus, the fieldbus cable must be disconnected before updating!
-

Requirement:

- You have installed the DTM (759-370) WAGOframe
- You have installed the DTM (759-371) WAGO service interface
- You have installed the DTM (759-922) USB driver
- You have installed the DTM (759-362) system update.
- Update packages are available for the connected 767 Series components.

System Update Procedure

To perform a system update for each 767 Series component, please complete the following steps:

1. Read 767 components' parameters and save them on your PC.
2. Update 767 Series components' firmware.
3. Rewrite parameters from your PC to the 767 Series components.
4. Set parameters to valid and finish the procedure.

7.1 Adding the DTM System Update

To add the DTM system update to WAGOframe, please proceed as follows:

1. In "Network View", right-click on the "WAGO Service Speedway" device driver.
2. In the **Add...** context menu, select "Add". The "Add" dialog box opens.

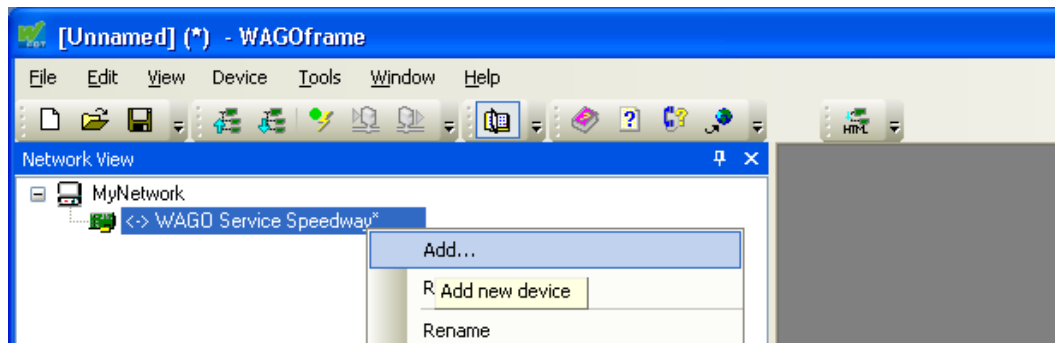
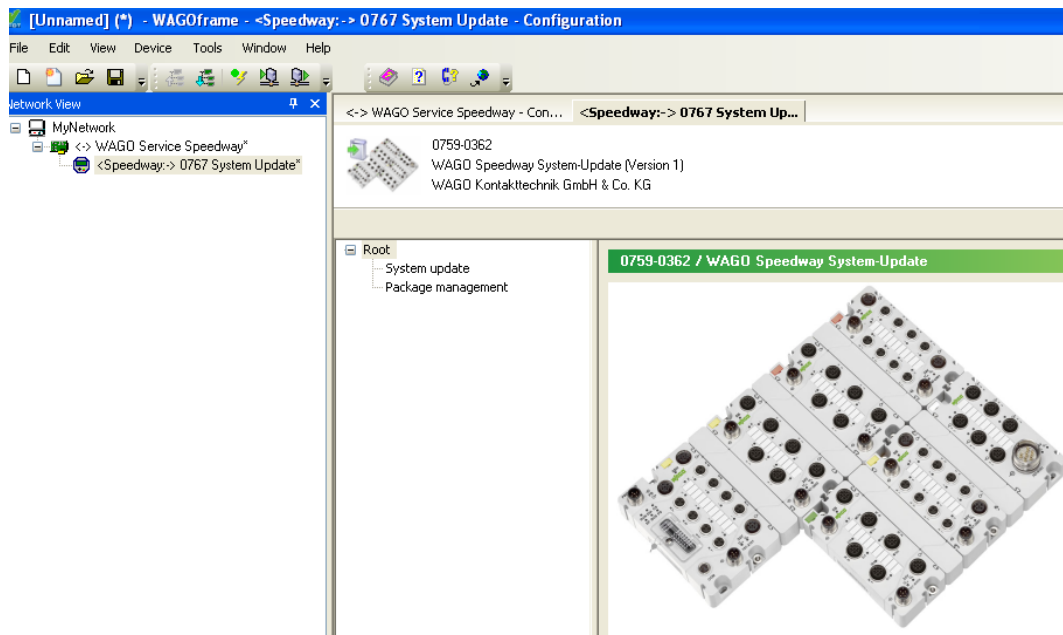

Figure 2: Adding the DTM system update

3. In the "Add" dialog box, select the **DTM 0767 System Update**.
4. Click **[OK]** to confirm your selection.



7.2 Go online to 767 Nodes using Update DTM

The firmware can only be updated when a communication connection exists between Update DTM and 767 node. Please proceed as follows:

1. In the "Network View", right-click on the "<Speedway:-> 0767 System Update" device driver.
2. In the context menu, select **Go online**. When the progress bar displays 100% and the entry is displayed in *bold italics*, the communication connection is established.

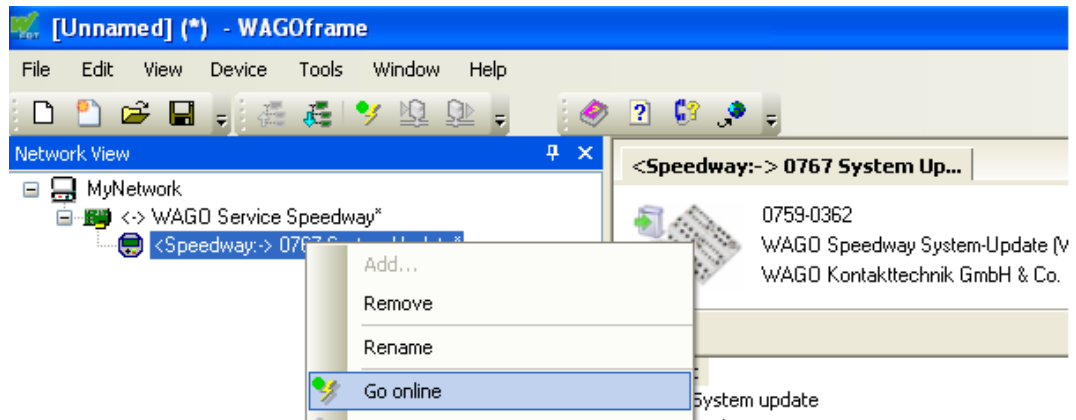

7.3 Updating the 767 Components

The current firmware is available from WAGO Support. Send an e-mail with the subject "Current Speedway Firmware" and the item number of the respective 767 components to: support@wago.com.

Import firmware packages

To use the received firmware packages, import them into the DTM system update. Please proceed as follows:

1. Save the received firmware packages with the ".wup" extension to any directory on your PC.
2. Open the DTM user interface by double clicking "**0767 System Update**" in the network view.

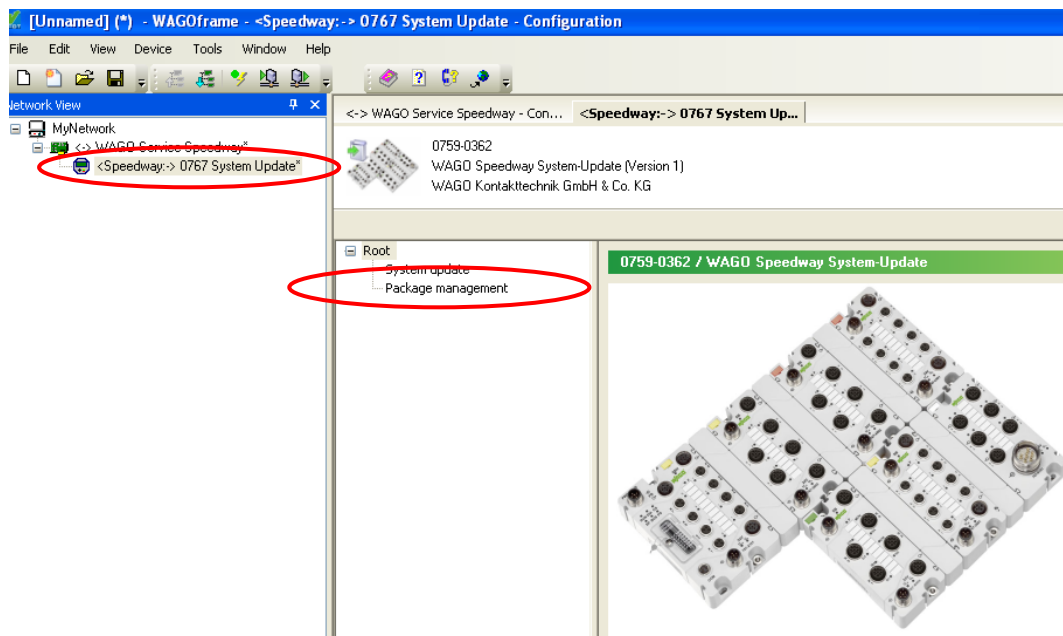

3. Click "Package Management" in the left window of WAGOframe.
4. To import the received firmware files, click **[Import]**. In the window that opens, go to the directory where you have saved the firmware files and select the file to be used. Click **[Open]** to apply the files.

Delete firmware packages

To maintain a clear "Package Management" interface, you can remove unneeded update packages from the view. Please proceed as follows:

1. Select the required firmware files in the right window.
2. Click [**Delete**] to remove the selected firmware packages.

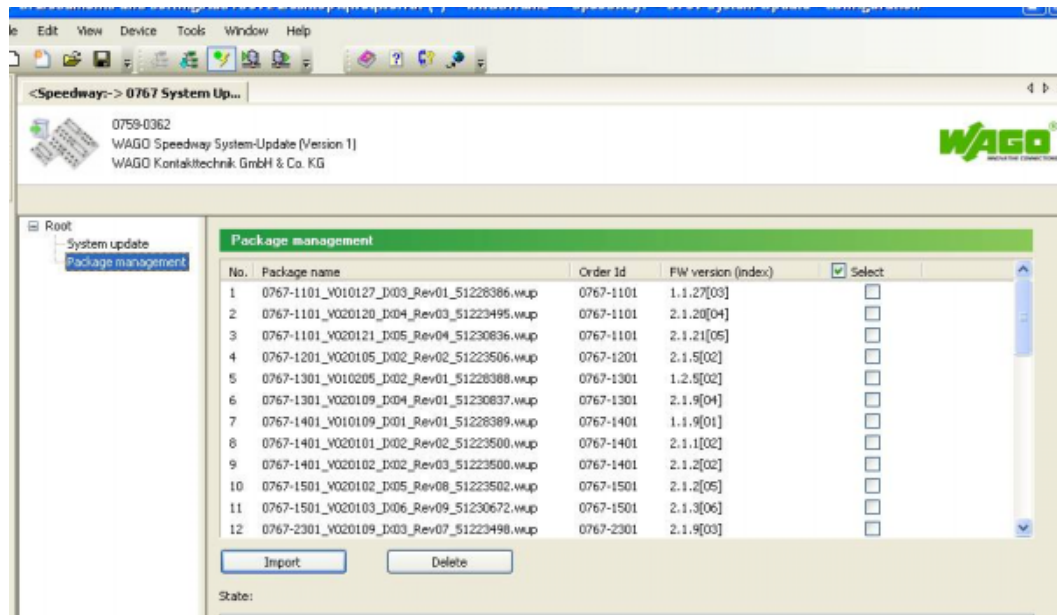

System update



Note

When updating the firmware of the fieldbus coupler, the saved module parameters may be overwritten. Therefore, check your existing configuration after updating the firmware.

Perform the system update here. The module settings you made normally remain unchanged. Otherwise, a corresponding warning message appears. If you still want to update the firmware, the 767 components are returned to their default state.

1. Click "System Update" in the left window.

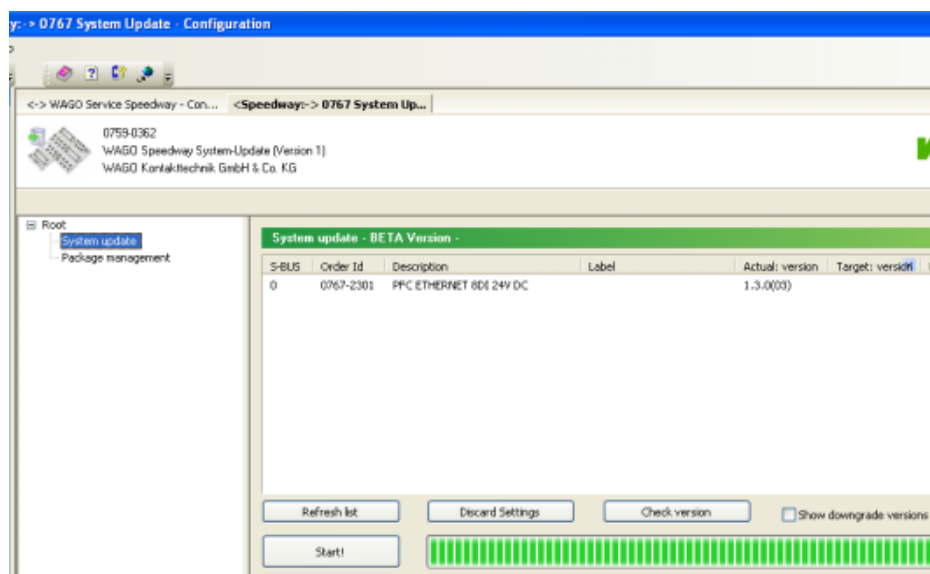

2. The fieldbus coupler with all connected I/O modules are listed in the right window. All 767 components that can be updated are pre-selected. If the pre-selection is incorrect or if specific 767 components should not be updated, deselect them.

"Actual: Version": Firmware currently present on the device

"Target: Version": Version of the firmware that should be loaded into the 767 components. If multiple "Target" versions can be selected, select the one relevant to you.

- Click **[Start!]** to update the system. The 767 components are marked in yellow while being updated.

Note



During the firmware updating process, the fieldbus coupler disconnects each of its COM ports. A PC equipped with Windows 2000 will detect this, and a Windows message appears. This is not an error message. Confirm the message by pressing **[OK]**.

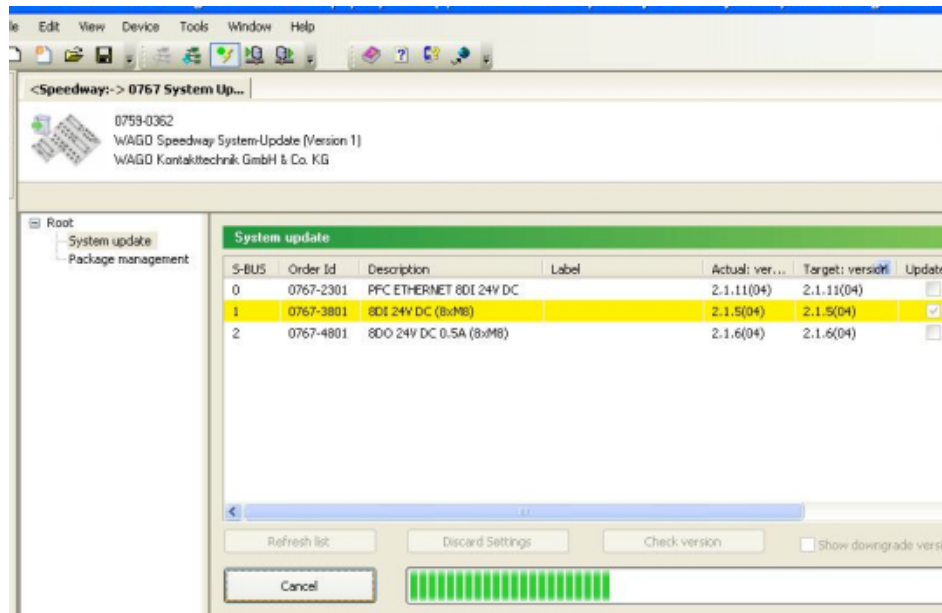

Button	Description
[Update List]	Use this function to read the node design and the view updates.
[Discard Settings]	Discard the selections and settings performed by you.
[Check Versions]	If you made your selection, click this button to perform a plausibility check. This checks whether the configuration you selected is possible (also automatically performed when starting the system update).
Display downgrade versions	If this checkbox is selected, the versions to downgrade a device are also displayed in the list of target versions.
[Start!]/[Abort]	Start/abort system update.

4. If the system update is finished, the updated 767 components are displayed in green (see figure).

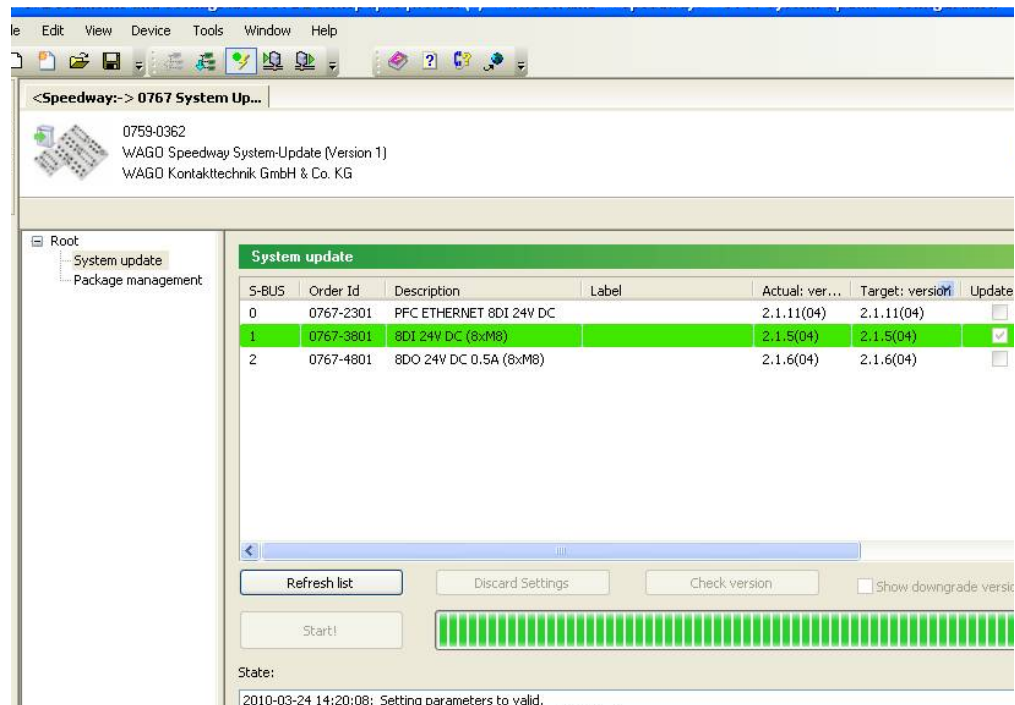

During system update, all relevant information is stored on your PC. Update can be repeated subsequently if the system update fails (components are displayed in red). In this case, original parameters remain unchanged.

If the update for a device fails, please contact WAGO Support.

Information

Further information is given in the WAGOframe manual.



WAGO Kontakttechnik GmbH & Co. KG
Postfach 2880 D-32385 Minden
Hansastraße 27 D-32423 Minden
Phone: +49 (0) 571/8 87 – 0
Fax: +49 (0) 5 71/8 87 – 1 69
E-mail: info@wago.com

Web: <http://www.wago.com>

